

SCHOLASTIC APTITUDE TEST
(For Students of Class X)

Time : 120 Minute

Max. Marks:100

INSTRUCTIONS TO CANDIDATES

Read the following instructions carefully before you open the test-booklet

1. Answers are to be given on a **separate OMR sheet**.
2. There are **100 questions** in this test. All are compulsory. The questions numbers 1 to 40 belong to **science**, **41 to 60** pertain to **Mathematics** and **61 to 100** are on **Social Science** subjects.
3. Please follow the instructions given on the OMR sheet for marking the answers.
4. Write your **eight - digit roll number** as allotted to you in the admission card clearly on the test-booklet and darken the appropriate circles on the **OMR sheet** as per instructions given.
5. Write down and darken **test-booklet number** in the appropriate circles on the **OMR sheet** as per instructions given.
6. Since the time allotted for this question paper is very limited and all questions carry equal marks, you should make the best use of it by not spending too much time on any one question.
7. **Rough work** can be done anywhere in the booklet but not on the **OMR sheet**.
8. Each correct answer will be awarded one mark.
9. **THREE WILL BE NO NEGATIVE MARKING.**
10. Please return only the **OMR sheet** to the invigilator after the test.
11. The English version of the question paper will be considered as final in case of any dispute arising out of variation in translation.

Please turn to the page and start answering immediately after you are asked to do so.

शैक्षिक अभिक्षमता परीक्षा
(कक्षा X के विद्यार्थियों के लिए)

समय : 120 मिनट

अधिकतम अंक: 100

परीक्षार्थियों के लिए अनुदेश

प्रश्न पुस्तिका खोलने से पहले, निम्नलिखित अनुदेशों को ध्यान से पढ़िए।

1. उत्तर एक अलग ओएमआर पत्र पर देने हैं।
2. इस परीक्षा में **100 प्रश्न** हैं। सभी प्रश्न अनिवार्य हैं। प्रश्न 1 से 40 विज्ञान 41 से 60 गणित और 61 से 100 सामाजिक विज्ञान के विषयों पर आधारित हैं।
3. कृपया उत्तर चिह्नित करने के लिए ओएमआर –पत्र पर दिए गए निर्देशों का अनुपालन कीजिए।
4. दिए गए निर्देशों के अनुसार आपके प्रवेश-पत्र दिए गए अपने आठ-अंकीय रोल नम्बर को प्रश्न पुस्तिका और ओएमआर-पत्र पर बिलकुल स्पष्ट रूप से लिखिए और उपर्युक्त गोलों को काला कीजिए।
5. दिए गए निर्देशों के अनुसार ओएमआर-पत्र पर प्रश्न-पुस्तिका संख्या लिखिए और उपर्युक्त गोलों को काला कीजिए।
6. चूंकि इस प्रश्न-पत्र के लिए निर्धारित समय बहुत सीमित है और सभी प्रश्नों के समान अंक हैं, इसीलिए समय का अधिकतम उपयोग कीजिए और किसी प्रश्न पर बहुत अधिक समय न लगाइए।
7. रफ कार्य पुस्तिका में कहीं भी किया जा सकता है, किन्तु ओएमआर-पत्र अलग कागज पर नहीं।
8. प्रत्येक सही उत्तर के लिए एक अंक प्रदान किया जाएगा।
9. गलत उत्तर के लिए कोई अंक नहीं काटा जाएगा।
10. कृपया परीक्षा के पश्चात केवल ओएमआर-पत्र ही निरीक्षक को वापस कीजिए।
11. अनुवादित सस्करण में अंतर से उठे किसी भी विवाद को स्थिति में प्रश्न-पत्र के अंग्रेजी सस्करण को निर्णायक माना जाएगा।
कृपया पृष्ठ पलटिए और अपना कार्य आरम्भ कीजिए।

NCERT - 2021

The copyright of the contents of this booklet rests with the NCERT and no part of it should be used by anybody in any immune whatsoever without the prior permission of the NCERT. The items are prepared

SCHOLASTIC APTITUDE TEST (SAT) PAPER & HINTS & SOLUTION

BIOLOGY

1. The plasma membrane (pm) forms the boundary of lung cells
Which of the following statements is true for the pm ?
A. pm is a semipermeable membrane
B. Water moves across the pm by Osmosis.
C. O₂ and CO₂ can cross the pm by diffusion
D. Na⁺ and K⁺ ions can pass the pm by diffusion
1. A, B, C & D 2. A, B, & D 3. B, C & D only 4. A, B & C only
Ans. (3)
2. Eukaryotic cells contain several membrane bound subcellular structures called Organelles. The vacuole is one such organelle found in both animal and plant cells. Which of the following statement are true for vacuoles?
A. Contain cell sap.
B. Provide turgidity to the plant cell.
C. Plant cell vacuoles are smaller than animals cell vacuoles.
D. Vacuoles store amino acids, sugar, acids and contain protein.
1. A, B, C & D 2. A, B & C only 3. A, B, & D 4. B, C, & D only
Ans. (3)
3. What is the reason for the Cardiac muscles not getting fatigued?
1. Presence of Single nucleus in cells of Cardiac muscles
2. Cylindrical cells protect the cardiac muscles from wear and tear
3. Because of branching in the cells
4. Presence of large number of mitochondria
Ans. (4)
4. Grafting is possible among dicot plants but not in monocot plants. This is due to presence of one of the following conditions in dicot plants.
1. Presence of open vascular bundles arranged in a ring.
2. Presence of collenchyma tissues.
3. Presence of intercalary meristem.
4. Larger diameter of stem.
Ans. (1)
5. Parenchyma, collenchyma and sclerenchyma are kinds of simple permanent tissues in plants. Which of the following statement is true for collenchyma?
A. Made up of dead cells
B. Have very little intercellular space.
C. Cells are irregularly thickened at the corners
D. Cell wall contains lignin
1. A, B, C & D 2. B & C only 3. A, B, & C only 4. B, C & D only
Ans. (2)
6. Trees of the genus Pinus are placed in higher groups compared to those of Marsilea genus because of the presence of one of the following features.
1. Differentiated plant body.
2. Presence of seed.
3. Presence of conducting tissue.
4. Presence of flowers.
Ans. (2)

7. Earth has vast diversity of animals. Each animal is unique in it-self and possesses certain distinguishing features. Match the animals listed in column A with their characteristic features given in column 'B' and column "C" and identify the correct match

Column 'A'	Column 'B'	Column 'C'
A. Pheretima	(a) Book gills	(i) Coxal gland
B. palaemon	(b) Colleterial Gland	(ii) Chloragogen cells
C. Palaemnaeus	(c) Book lungs	(iii) Green Gland
D. Periplaneta	(d) Calciferous glands	(iv) Unicose glands

1. A – (a) – (i) ; B – (b) – (ii) ; C – (c) – (iii) ; D – (d) – (iv)
 2. B – (a) – (iii) ; B – (d) – (iv) ; C – (a) – (i) ; D – (c) – (ii)
 3. A – (c) – (iv) ; B – (a) – (i) ; C – (b) – (ii) ; D – (d) – (iii)
 4. A – (d) – (ii) ; B – (c) – (iii) ; C – (a) – (iv) ; D – (b) – (i)

Ans. (4)

8. What will happen to cells of cyanobacteria if they are placed in purified water?

1. They will swell and burst
 2. They will shrink
 3. They will swell but will not burst
 4. They will not show any change

Ans. (3)

9. Hutington's disease is an autosomal disorder characterized by movement, cognitive and psychiatric disorders. Study the given pedigree and identify the genotype of II-3 and II-4.
 [Note: Solid squares/circles represent affected individuals and empty squares/circles denote unaffected normal individuals.]

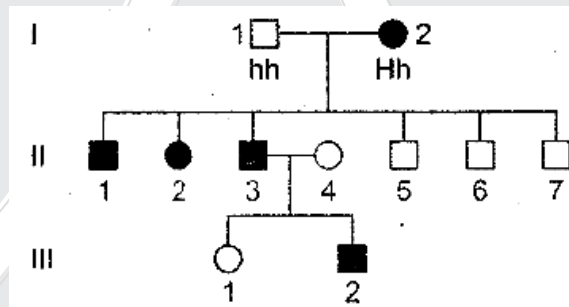

1. II – 3 : Hh ; II – 4 : hh
 2. II – 3 : HH ; II – 4 : Hh
 3. II – 3 : HH ; II – 4 : hh
 4. II – 3 : Hh ; II – 4 : HH

Ans. (1)

10. When a tall plant with round seeds was hybridized with a dwarf plant with wrinkled seeds; all offspring in F₁ generation were tall plants that produced round seeds. As per Mendel's law of independent assortment, what percent of offspring will produce wrinkled seeds if F₁ is crossed with tall plant producing wrinkled seeds?

1. 10
 2. 20
 3. 50
 4. 100

Ans. (3)

11. What would happen to earth if carbon dioxide was absent from its atmosphere ?

1. The earth would be a pleasant place.
 2. Absence of carbon dioxide would not make any difference to earth.
 3. Earth would be devoid of life.
 4. Earth would have only animal life.

Ans. (3)

12. The following figure represents the flow of energy in a pyramid of food. If this ecosystem receives 1,00,000 kcal of sunlight energy of, the energy finally available to Tertiary Consumer (TC) is

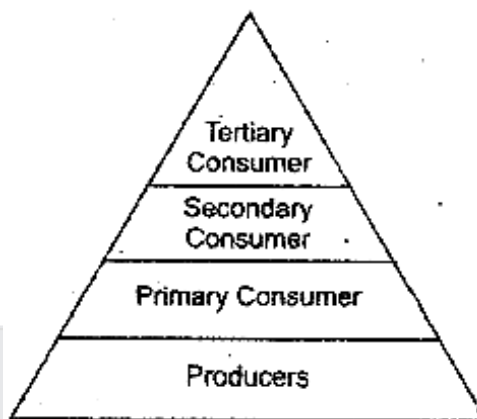

1. 1000 kcal 2. 100 kcal 3. 10 kcal 4. 1 kcal
Ans. (2)

13. Pollen grains of a fruiting plants species are deposited on the female flower by a pollinator. However, the female flower does not get fertilized. Which of the following observation is true?
 1. Fruit will not be formed.
 2. Only seed set will not occur
 3. Normal fruit and seeds will be formed
 4. Only fruit wall will be formed.

Ans. (1)

CHEMISTRY

14. The values of stoichiometric coefficients m, x, y and z in the following reactions after balancing are, respectively

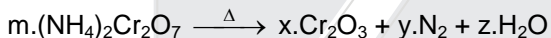

1. 2, 1, 1, 2 2. 2, 2, 2, 4 3. 1, 1, 1, 4 4. 2, 2, 1, 2

Ans. (3)

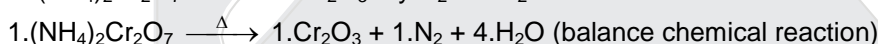
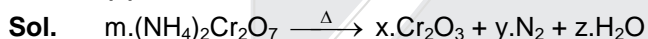

on comparing these to reaction

$$m = 1 \quad y = 1$$

$$x = 1 \quad z = 4$$

Option (3) is correct

15. Identify the incorrect statement for the reaction

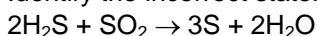

1. 1 mole H₂O is produced per mole of H₂S consumed
 2. 3 gram of S is produced for every gram of SO₂ consumed
 3. two – thirds of S produced comes from H₂S
 4. The number of moles of various atoms present before and after the reaction is same

Ans. (2)

- Sol.** 1. 1 mole H₂O is produced per mole of H₂S consumed. **(Correct statement)**
 2. 3 gram of S is produced for every gram of SO₂ consumed. **(Incorrect statement)**
 3. two – thirds of S produced comes from H₂S. **(Correct statement)**
 4. The number of moles of various atoms present before and after the reaction is same. **(Correct statement)**

Option (2) is correct

16. You are provided with aqueous solutions of three salts A, B and C 2 -3 drop of blue litmus solution, red litmus solution and phenolphthalein were added to each of these solutions in the separate experiments. The change in colours of different indicator were recorded in the following table

Sample	With blue litmus solution	With red litmus solution	With phenolphthalein
A	No change	Turns blue	Turns pink
B	No change	No change	No change
C	Turns red	No change	No change

On the basis of above observations identify A, B and C from the following options :

1. A = NaCl, B = CH₃COONa, C = FeCl₃
2. A = CH₃COONa, B = NaCl, C = FeCl₃
3. A = FeCl₃, B = NaCl, C = CH₃COONa
4. A = FeCl₃, B = CH₃COONa, C = NaCl

Ans. (2)

Sol. NaCl – Neutral in nature

CH₃COONa – basic in nature (Turn red litmus to blue)

FeCl₃ - acidic in nature (Turn blue litmus to red)

Option (2) is correct

17. Which of the following are NOT correct methods for separating the component of given mixture ?

- I. The mixture of iodine and sodium chloride by sublimation.
- II. Plant pigment by chromatography.
- III. Mixture of acetic acid and water by separating funnel.
- IV. Oxygen, Argon and nitrogen from air by fractional distillation.

1. I only
2. III only
3. II and III
4. II, III and IV

Ans. (2)

Sol. Acetic acid and water are miscible to each other while separating funnel is used to separate mixture of immiscible liquids.

Option (2) is correct.

18. The compound 'A' when treated with alkaline potassium permanganate gives 'B' and with conc. sulphuric acid gives 'C' and 'D'. The compounds A, B, C and D are respectively :

1. C₂H₄, CH₃COONa, C₂H₅OH, H₂O
2. CH₃COOH, C₂H₄, C₂H₅OH, H₂O
3. C₂H₅OH, CH₃COOH, C₂H₄, H₂O
4. CH₃OH, HCOOH, H₂O, CH₄

Ans. (3)

Sol. $\text{CH}_3 - \text{CH}_2 - \text{OH} \xrightarrow{\text{alkaline KMnO}_4} \text{CH}_3\text{COOH}$
Ethanol (A) Acetic acid (B)

$\text{CH}_3 - \text{CH}_2 - \text{OH} \xrightarrow{\text{conc. H}_2\text{SO}_4} \text{CH}_2 = \text{CH}_2 + \text{H}_2\text{O}$
Ethanol (A) ethene (C) water (D)

Option (3) is correct.

19. Match the chemical reaction given in the List-I with the type of chemical reactions given in the List-II and select the correct answer from the option given below :

	List-I (Chemical reaction)		List-II (Type of chemical reactions)
I	$\text{CH}_3 - \text{CH}_2 - \text{OH} \xrightarrow{\text{acidified K}_2\text{Cr}_2\text{O}_7}$	A.	Addition
II	$\text{C}_2\text{H}_4 + \text{H}_2 \xrightarrow{\text{Ni catalyst}}$	B.	Elimination
III	$\text{CH}_4(\text{g}) + \text{Cl}_2(\text{g}) \xrightarrow{\text{sunlight}}$	C.	Redox
IV	$\text{CH}_3 - \text{CH}_2 - \text{OH} \xrightarrow{\text{Heat / conc. H}_2\text{SO}_4}$	D.	Substitution

1. I-C, II-D, III-A, IV-B
2. I-B, II-A, III-D, IV-C
3. I-C, II-A, III-D, IV-B
4. I-B, II-D, III-A, IV-C

Ans. (3)

Sol. (I) $\text{CH}_3 - \text{CH}_2 - \text{OH} \xrightarrow{\text{acidified K}_2\text{Cr}_2\text{O}_7} \text{CH}_3\text{COOH}$ (Redox reaction)

(II) $\text{C}_2\text{H}_4 + \text{H}_2 \xrightarrow{\text{Ni catalyst}} \text{C}_2\text{H}_6$ (Addition reaction)

(III) $\text{CH}_4(\text{g}) + \text{Cl}_2(\text{g}) \xrightarrow{\text{sunlight}} \text{CH}_3\text{Cl} + \text{HCl}$ (Substitution reaction)

(IV) $\text{CH}_3 - \text{CH}_2 - \text{OH} \xrightarrow{\text{Heat / conc. H}_2\text{SO}_4} \text{C}_2\text{H}_4 + \text{H}_2\text{O}$ (Elimination reaction)

Option (3) is correct.

20. Two beakers A and B contains iron (II) sulphate solution. In the beakers A and B small pieces of copper and zinc are placed respectively. It is found that a grey deposit forms on the zinc but not on the copper form these observation it can be concluded that :

1. Zinc is more active metal followed by iron and then copper
2. Zinc is more active metal followed by copper and then iron
3. Iron is more active metal followed by zinc and then copper
4. Iron is more active metal followed by copper and then zinc

Ans. (1)

Sol. Zinc is more active metal followed by iron and then copper

$Zn > Fe > Cu$ (Decreasing order of activity)

Option (1) is correct.

21. Sulphur powder is heated on a spatula. A piece of both moist blue and red litmus papers are both one by one near the gas evolved during heating. The action of gas on the moist litmus paper will be :

1. No change in the colour of both litmus papers
2. Blue litmus paper become red
3. Red litmus paper become blue
4. Blue litmus paper turns black

Ans. (2)

Sol. Blue litmus paper become red.

$S + O_2 \rightarrow SO_2$

SO_2 is acidic in nature.

Option (2) is correct.

22. Two samples A and B of a pure substance containing elements X and Y are obtained from two different sources. 5 g of sample A contains 1.25g of Z. Samples B is made of 75% of Y by weight. This is an illustration of which of the following law ?

1. Law of constant proportion
2. Law of multiple proportion
3. Law of mass conservation
4. Avagadro's Law

Ans. (1)

Sol.

5g of sample (A) = Y	+		+	Z
		3.75 (calculate)		1.25g (given)
		(75% of 5g)		(25% of 5g)..... (i)

Sample (B) = Y	+		+	Z
		75% (given)		25% (calculate)(ii)

On comparing (i) and (ii) they obey the law of constant proportion.

Option (1) is correct.

23. An element X with atomic number 13 combines with another element Y of atomic number of 17. The formula of compound formed and nature of bond will be :

1. XY_3 , ionic
2. XY_3 , covalent
3. X_3Y ionic
4. X_3Y covalent

Ans. (2)

Sol. Element X is aluminium (Z = 13) and element Y is chlorine (Z = 17)

They combine to form compound XY_3 and nature of bond is covalent

Option (2) is correct.

24. Select the correct options from the following statements :

- I. $^{12}_6C$ and $^{14}_6C$ are isobar of each other.
 - II. $^{12}_6C$ react with $^{16}_8O$ to form a product which contains ionic bonds.
 - III. $^{40}_{20}Ca$ and $^{40}_{18}Ar$ are isobar of each other
 - IV. $^{40}_{20}Ca$ react with $^{16}_8O$ to form a compound whose aqueous solution is known as lime water.
1. I and II
 2. I and III
 3. III and IV
 4. I and IV

Ans. (3)

Sol. I. $^{12}_6C$ and $^{14}_6C$ are isobar of each other. **(Incorrect statement)**

II. $^{12}_6C$ react with $^{16}_8O$ to form a product which contains ionic bonds. **(Incorrect statement)**

III. $^{40}_{20}Ca$ and $^{40}_{18}Ar$ are isobar of each other **(Correct statement)**

IV. $^{40}_{20}Ca$ react with $^{16}_8O$ to form a compound whose aqueous solution is known as lime water.

(Correct statement)

Option (3) is correct.

25. Identify the correct order of atomic radii of following element :

1. Na < Li < Rb < Cs 2. Li < K < Rb < Cs
3. Li < Na < Cs < K 4. Na < K < Cs < Rb

Ans. (2)

Sol. When we move from top to bottom in a column they ionic radii will be increase as number of shell in atom increases.

Li < K < Rb < Cs

Option (2) is correct.

26. Which of the following statements are true ?

- I. On heating the kinetic energy of particle in solids does not change because they have a fixed position.
II. Sublimation is the change of gaseous states directly to solid states without going through liquid state and vice versa.
III. The movement of particles from an area of higher concentration to lower concentration is called diffusion.
IV. The rate of evaporation is not affected by increasing the temperature.

1. I, II and III 2. II and IV 3. II, III and IV 4. II and III

Ans. (4)

Sol. I. On heating the kinetic energy of particle in solids does not change because they have a fixed position. **(Incorrect statement)**

II. Sublimation is the change of gaseous states directly to solid states without going through liquid state and vice versa. **(Correct statement)**

III. The movement of particles from an area of higher concentration to lower concentration is called diffusion. **(Correct statement)**

IV. The rate of evaporation is not affected by increasing the temperature. **(Incorrect statement)**

Option (4) is correct.

27. A train moving at uniform 90 km/h is approaching a flag station whose platform is 500 m long. Station master is standing at the centre of the platform. Train starts blowing whistle when engine is 1 km away from near end of the platform and continues blowing whistle till engine crosses of the platform without stopping. If the speed of the sound is assumed to be 300 m/s, then the duration for which station master hears the whistle is?

1. 55.80 sec 2. 56.67 sec 3. 60.00 sec 4. 60.30 sec

Ans. (2)

Sol. $t = \frac{1500}{300} - \frac{1250}{300} + \frac{250}{300} = 56.67 \text{ sec}$

28. A swimmer can swim in still water at a speed of 15 km/h. A river is flowing at 5 km/h. The swimmer starts from a point and swim 1 km upstream and then returns by swimming downstream back to original position. During this, the average speed of his/her swimming is:

1. 20/3 km/h 2. 10 km/h 3. 40/3 km/h 4. 20 km/h

Ans. (3)

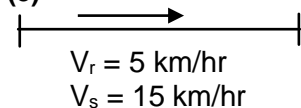

Sol.

Time taken in up stream $t_1 = \frac{1}{15-5} = \frac{1}{10} \text{ hr}$

Time taken in down stream = $\frac{1}{15+5} = \frac{1}{20} \text{ hr}$

Average speed = $\frac{2}{\left(\frac{1}{10} + \frac{1}{20}\right)} = \frac{2 \times 20}{3} = \frac{40}{3} \text{ km/hr}$

29. A car P is moving with a uniform speed of 72 km/h towards another car Q at rest on a straight level road. At a particular instant when the distance between P & Q is 525 m the car Q started accelerating at 2 m/s^2 towards P Find the distance travelled by Q when both the cars meet.
 1. 300 m 2. 225 m 3. 100 m 4. 30 m

Ans. (2)

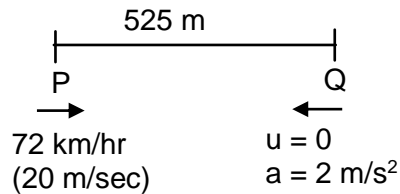

Sol.

Suppose they will meet after time t then
 Distance covered by P + Distance covered by Q = 525 m

$$20t + \frac{1}{2} \times 2t^2 = 525$$

$$20t + t^2 = 525$$

$$t^2 + 20t - 525 = 0$$

$$t^2 + 35t - 15t - 525 = 0$$

$$t(t + 35) - 15(t + 35) = 0$$

$$(t + 35)(t - 15) = 0$$

$$t = 15 \text{ sec}$$

$$t = -35 \text{ see not possible}$$

Distance covered by Q

$$S = \frac{1}{2} \times 2 \times (15)^2$$

$$S = 225 \text{ m}$$

30. Figure shows the velocity versus time graph for a block of mass 50 g sliding on a rough floor. The average rate at which energy dissipates (in J/s) due to the force of friction is:

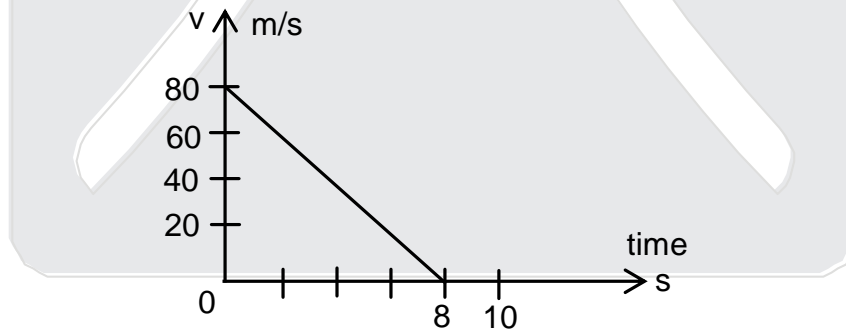

1. 5.0 J/s 2. 10.0 J/s 3. 20.0 J/s 4. 40.0 J/s

Ans. (3)

Sol. $KE_i = \frac{1}{2} \left(\frac{50}{1000} \right) (80)^2 = 160 \text{ J}$

$$KE_f = 0$$

$$\text{Average rate of energy dissipates} = \frac{160 - 0}{8} = 20.0 \text{ J/s}$$

31. A ball of mass 100 g is dropped from a height of 1 m. It loses 10% of its energy every time when it bounces off the floor. After 3 bounces, it can reach the half-way to maximum height, its kinetic energy (upto two decimal points) would be (take $g = 10 \text{ m/s}^2$)

1. 0.35 J 2. 0.36 J 3. 0.70 J 4. 0.73 J

Ans. (2)

Sol. At first bounces K.E. = $\frac{90}{100} \times mgh = 0.9 \times 0.1 \times 10 \times 1 = 0.9$ Joule

At II bounces K.E. = $\frac{90}{100} \times 0.9 = 0.81$ Joule

At third bounces K.E. = $\frac{90}{100} \times 0.81 = 0.9 \times 0.81 = 0.729$ Joule

It reaches half the height

So K.E. = $\frac{0.729}{2}$

K.E. = 0.36 Joule

32. A block of mass 3 kg and density ρ . suspended from a spring balance is immersed in a liquid of density $\rho/3$. Then the balance would read weight as:

1. 0 2. $2/3$ kg 3. 1 kg 4. 2 kg

Ans. (4)

Sol.

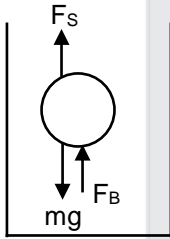

$$F_s = mg - F_B$$

$$= \rho v g - \frac{\rho}{3} v g$$

Given $\rho v = 3$

$$F_s = 3g - \frac{3}{3}g = 2g$$

So reading of spring = 2kg

33. Cost of coal is Rs.5 per kg and can produce energy of 20 MJ/kg. If a power station uses coal to produce electricity with 25% efficiency, then the cost of coal for producing 1 unit (1 kw/h) of electricity in Rs:

1. 0.9 2. 3.6 3. 9.0 4. 36.0

Ans. (2)

Sol.

$$20 \text{ MJ/Kg} = 2 \times 10^7 \text{ Joule/kg}$$

1 kwh = 3.6×10^6 Joule it is 25%, so

$$\text{Net energy } 3.6 \times 10^6 \times \frac{100}{25} = 14.4 \times 10^6 \text{ Joule}$$

$$\text{Mass of coal} = \frac{14.4 \times 10^6}{2 \times 10^7}$$

$$m = \frac{14.4}{20}$$

$$\text{Cost of coal} = \frac{14.4 \times 5}{20} = \frac{72.0}{20} = \frac{7.2}{2}$$

Cost of coal = 3.6 Rs/kg

34. Two different instruments (say, guitar and harmonium). playing same music, their sound appears different though they play same frequency, because:

1. They have different loudness.
2. They are played by different persons and hence difference in tuning.
3. They have different quality.
4. They create different pitch.

Ans. (3)

Sol.

Quality depend on wave form which are different for different instrument.

35. Sound travels at a speed of 1450 ms^{-1} through water. A submarine detects objects around it by sending sound waves and detecting echo (reflected sound) heard after 4 seconds. Then the object must be at a distance of:

1. 1.450 km 2. 2.900 km 3. 4.350 km 4. 5.800 km

Ans. (2)

Sol. $d = \frac{v \times t}{2} = \frac{1450 \times 4}{2} = 2900\text{m} = 2.9\text{km}$

36. A small pencil of length 10 cm is kept along the axis of a concave mirror of radius of curvature 40 cm with its tip touching the mirror. The size of pencil's image would appear to be:

1. 5 cm 2. 10 cm 3. 20 cm 4. infinite

Ans. (3)

Sol. For A image of also at A

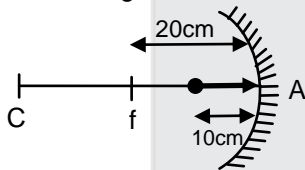

For B

$u = -10 \text{ cm}$

$f = -20 \text{ cm}$

$v = +20 \text{ cm}$

So length of image $\rightarrow 20 - 0 = 20 \text{ cm}$

37. A 10 V battery is connected to a series combination of two resistances of 4000Ω and 6000Ω . A non-ideal voltmeter of resistance $10,000 \Omega$ connected across 4000Ω reads 3.226 V. What would be the value if the same voltmeter connected across 6000Ω ?

1. 3.326 V 2. 4.326 V 3. 3.238 V 4. 4.838 V

Ans. (4)

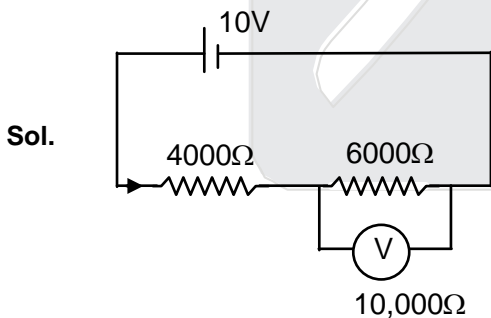

Sol.

$$4000 + \frac{6000 \times 10,000}{16000}$$

$$4000 + \frac{3 \times 2500}{2}$$

$$4000 + 3750$$

$$R_{eq} = 7750 \Omega$$

$$I = \frac{10}{7750}$$

$$\text{Reading of volt meter} = \frac{10}{7750} \times 3750 = \frac{3750}{775} = 4.838 \text{ V}$$

38. Consider two circuits:
 (i) A: in which N identical bulbs are connected in series across a battery of emf E.
 (ii) B: in which N bulbs identical to those in A are connected in parallel across similar battery of emf E.
 P_A : Power dissipating in each bulb in A.
 P_B : Power dissipating in each bulb in B.
 P_{AT} : Total power delivered by battery in circuit A.
 P_{BT} : Total power delivered by battery in circuit B.
 Choose the correct option:
 1. $P_A = N P_{BT}$ 2. $P_{BT} = N^2 P_{AT}$ 3. $P_{BT} = N P_{AT}$ 4. $P_B = N^2 P_A$

Ans. (4)
Sol.

For series combination

$$P_A = \frac{P}{N}$$

For parallel combination

$$P_B = NP$$

$$\text{So } P_B = N^2 P$$

39. Six resistances, each of value given R value are connected between two points A and B as shown in the figure:

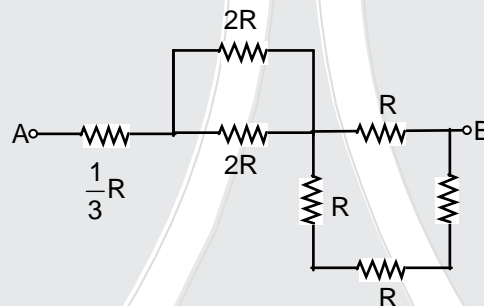

The combined value of resistance between points A and B is :

1. $2R$ 2. R 3. $\frac{4}{3}R$ 4. $\frac{5}{3}R$

Ans. (Bonus)

Sol.
$$\frac{R}{3} + R + \frac{2R}{3} = \frac{R + 3R + 2R}{3} = \frac{6R}{3} = 2R$$

40. A body travels the distance $AB = \ell$ with a speed 2 m/s. Thereafter, it travels $BC = \ell'$ with speed 1.5 m/s and the remaining $CC' = (\ell - \ell')$ with 0.5 m/s. Calculate the average speed for this journey assuming that the body takes same time in travelling distances BC & CC'.

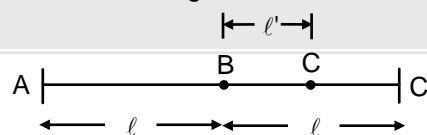

1. 2 m/s 2. 1.33 m/s 3. 0.66 m/s 4. 0.8 m/s

Ans. (2)
Sol.

For BC'

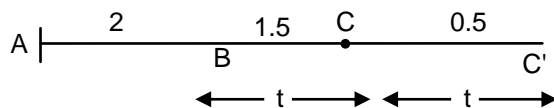

$$V_{av} = \frac{V_1 + V_2}{2} = \frac{1.5 + 0.5}{2} = 1 \text{ m/s}$$

For AC'

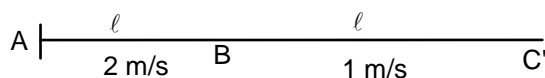

$$\frac{2V_1 V_2}{V_1 + V_2} = \frac{2 \times 2 \times 1}{2 + 1} = \frac{4}{3} = 1.33 \text{ m/s}$$

MATHEMATICS

41. For real numbers p,q and a, if the polynomial $x^3-3px + 2q$ is divisible by the polynomial $x^2+ 2ax +a^2$, then which of the following is correct.

1. $3p = 2q$ 2. $p^2 = q^3$ 3. $p^3 = q^2$ 4. $27p^3 = 4q^2$

Ans. (3)

Sol. $x^3-3px + 2q$ have factor $(x+a)^2$

So it root are $-a, -a, \alpha$

$-a -a + \alpha = 0$

$\alpha = 2a$

$(-a) (-a) (\alpha) = -2q$

$(-a) (-a) (-2a) = -2q$

$a^3 = -q$

Now $-a$ satisfy equation

$\therefore -a^3 + 3pa + 2q = 0$

$q + 3pa + 2q = 0$

$pa = -q$

$p^3 a^3 = -q^3$

$p^3(-q) = -q^3$

$p^3 = q^2$

42 The value of $(3^{1/2} - 1) (3^{1/2} + 3^{1/4} + 1) (3^{1/2} - 3^{1/4} + 1)$ is :

1. 1 2. $3\sqrt{3}$ 3. $3\sqrt{3} - 1$ 4. $3\sqrt{3} + 1$

Ans. (3)

Sol. Let $3^{1/4} = x$

$(x^2-1) (x^2+x+1) (x^2-x+1)$

$(x-1) (x+1) (x^2+x+1) (x^2-x+1)$

$(x^3-1) (x^3+1)$

x^6-1

$(3^{1/4})^6 - 1$

$3^{6/4} - 1$

$3^{3/2} - 1 = 3\sqrt{3} - 1$

43. Given that the system of equations $mx + 2y = 10, 3x-2y = 0$ have the integer solution. then the possible values of m are

1. 2 and 8 2. 2 and -8 3. -2 and -8 4. -2 and 8

Ans. (2, 3)

$mx + 2y = 10$

Sol. $3x - 2y = 0$
 $(m + 3)x = 10$

$x = \frac{10}{m+3}$ as x is integer

$\therefore m+3 = \pm 1, 2, 5, 10$

$m = -4, -5, -4, -8, -13, -2, -1, 2, 7$

If we put $m = -2, 2, -8$

We get x, y both integer

44. Consider an arithmetic progression with n terms. If the common difference is increased by 1, then n^{th} term increases by 19. If the 5th term of the progression is 28 and the average of the first and last terms is 61, then the 10 term of the progression is
 1. 54 2. 56 3. 58 4. 60

Ans. (3)

Sol. $a, a + d, a + 2d, \dots$
 $a, a+d+1, a +2(d+1) \dots$
 n^{th} term increases by 19
 $a + (n-1)(d+1) - (a+(n-1)d) = 19$
 $n - 1 = 19$
 $n = 20$
 $\frac{a + a + (n-1)d}{2} = 61$
 $2a + (n-1)d = 122$
 $n = 20$
 $2a + 19d = 122 \dots\dots\dots(1)$
 $a + 4d = 28 \dots\dots\dots(2)$
 $a = 4$
 $d = 6$
 $T_{10} = a + 9d$
 $= 4 + 9 \times 6$
 $= 4 + 54 = 58$

45. The ages of the members of a club are in arithmetic progression with common difference 3 months. The sum of ages of all the members is 300 years and the youngest member is a child of age 9 years. Then, the age of the eldest member is :
 1. 16 years 2. 15 years 3. 14 years 4. 13 years

Ans. (2)

Sol. $d = 3 \text{ month} = \frac{3}{12} \text{ yr} = \frac{1}{4} \text{ yr}$
 Youngest = 9 yr = a
 $S_n = 300$
 $300 = \frac{n}{2} \left[18 + (n-1)\frac{1}{4} \right]$
 $n(n+71) = 2400 = 96 \times 25$
 on solving $n = 25$
 So eldest
 $a + (n-1)d$
 $= 9 + 24 \times \frac{1}{4}$
 $= 9 + 6 = 15$

46. A sum of Rs. 27000 was divided equally among a certain number of persons. Had there been 20 more persons, each would have got Rs. 480 less. The number of persons, initially, was
 1. 24 2. 25 3. 45 4. 48

Ans. (2)

Sol. Let no. of person = x
 $\frac{27000}{x} - \frac{27000}{x+20} = 480$
 $\frac{1}{x} - \frac{1}{x+20} = \frac{480}{27000}$
 $x(x+20) = 225 \times 5 = 45 \times 25$
 on solving we set $x = 25$

49. The angle of elevation of the top of a ladder leaning against a wall measured from a distance of 7.3 metres from the foot of the ladder is 45° . Suppose that the vertical height of the top of the ladder is 17.3 metres. Then the best approximation of the angle of inclination of the ladder with the wall is
 1. 15° 2. 30° 3. 45° 4. 60°

Ans. (4)

Sol.

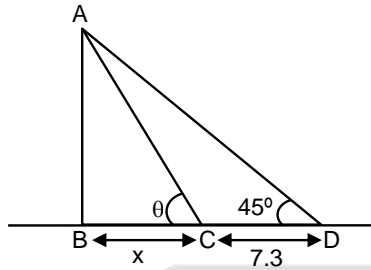

$\triangle ABD$

$$\tan 45^\circ = \frac{AB}{x+7.3} = \frac{17.3}{x+7.3}$$

$$1 = \frac{17.3}{x+7.3}$$

$$x + 7.3 = 17.3$$

$$x = 10$$

$$\tan \theta = \frac{AB}{BC} = \frac{17.3}{10} = 1.73 \approx \sqrt{3}$$

$$\theta = 60^\circ$$

50. If both the roots of the equation $x^2 - 2mx + m^2 - 1 = 0$ are greater than -2 but less than 4 , then
 1. $-1 < m < 3$ 2. $1 < m < 4$ 3. $-2 < m < 0$ 4. $1 < m < 3$

Ans. (1)

Sol.

$$x^2 - 2mx + m^2 - 1 = 0$$

$$(x - (m-1))(x - (m+1)) = 0$$

$$x = m - 1, m + 1$$

$$-2 < m - 1 < 4$$

$$-2 < m + 1 < 4$$

$$-1 < m < 5$$

$$-3 < m < 3$$

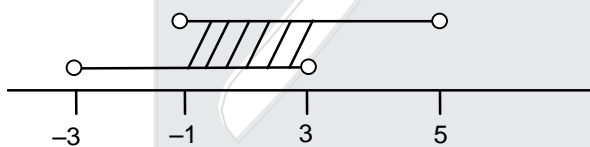

$$m \in (-1, 3)$$

51. Consider the collection of points (a, b) in the coordinate plane such that a and b are integers such that $-5 \leq a \leq 5$ and $-5 \leq b \leq 5$. A point is selected at random from the collection. What is the probability that the selected point is at a distance of at most 2 units from the origin ?
 1. $11/100$ 2. $13/100$ 3. $11/121$ 4. $13/121$

Ans. (4)

Sol.

$$-5 \leq a \leq 5$$

$$-5 \leq b \leq 5$$

Total point (a, b) with $a, b \in I = 11 \times 11 = 121$ distance between origin $(a, b) \leq 2$

$$\sqrt{a^2 + b^2} \leq 2$$

$$a^2 + b^2 \leq 4$$

So possible points (a, b)

$(0, 0) (0, 1) (0, 2) (0, -1) (0, -2)$

$(1, 0) (1, 1) (1, -1)$

$(2, 0)$

$(-1, 0) (-1, 1) (-1, -1)$

$(-2, 0)$

$$\text{Total points} = 13 \qquad \text{Required probability} = \frac{13}{121}$$

52. In the parallelogram ABCD, M and N are respectively the midpoints of AB and AD. The points M and N are joined to form the triangle AMN. The area of the triangle AMN and the area of the parallelogram ABCD are in the ratio .

1. 1 : 4 2. 1 : 6 3. 1 : 8 4. 1 : 9

Ans. (3)
Sol.

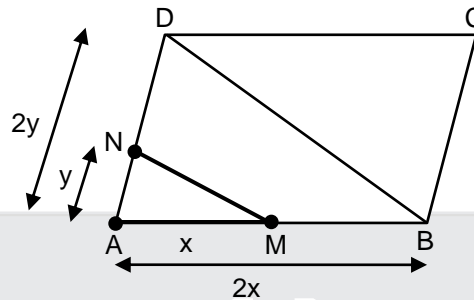

Let Area of $\triangle AMN = A$

$\triangle AMN \sim \triangle ADB$

$$\frac{\text{ar}(\triangle AMN)}{\text{ar}(\triangle ADB)} = \left(\frac{AM}{AB}\right)^2 = \left(\frac{x}{2x}\right)^2 = \frac{1}{4}$$

$\text{ar}(\triangle ADB) = 4A$

$\text{ar}(\triangle ABCD) = 8A$

$\therefore \text{ar}(\triangle AMN) = A$

\therefore ratio 1 : 8

53. In the adjoining figure, ABCD is a rectangle. The area of $\triangle BEG = 503 \text{ cm}^2$, the area of $\triangle JFD = 408 \text{ cm}^2$ and the area of quadrilateral EHFA = 1113 cm^2 . The area (in cm^2) of the shaded region is

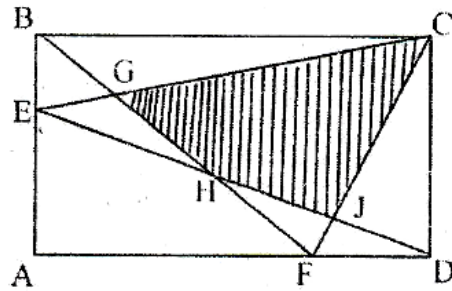

(1) 2021

2. 2019

3. 1208

4. 1018

Ans. (Bonus)

54. In the adjoining figure, ABC is right angled at B. The point D is on AC such that $BD = BC$ and BDEF is a parallelogram. If $m \angle BEF = 10^\circ$, then $\angle ADE$ is equal to

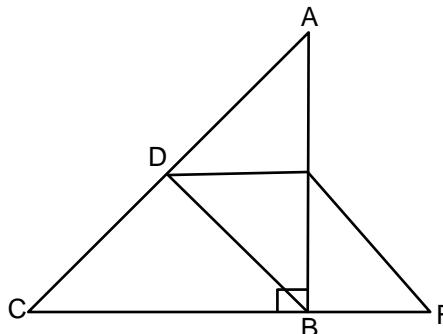

1. 50°

2. 40°

3. 25°

4. 20°

Ans. (1)

Sol.

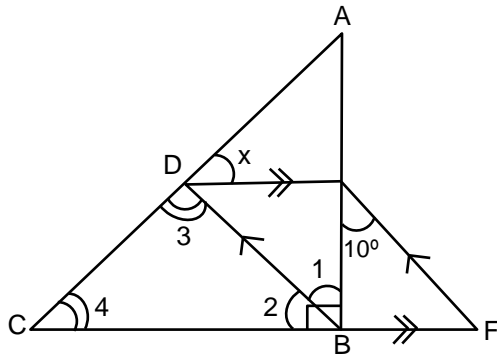

$$\begin{aligned} \angle 1 &= 10^\circ \text{ (C.A.)} \\ \angle 2 &= 90 - \angle 1 = 90^\circ - 10^\circ = 80^\circ \\ \angle 3 &= \angle 4 = \frac{(180 - 80)}{2} = 50^\circ \\ x &= \angle 3 \text{ (C.A.)} \\ x &= 50^\circ \end{aligned}$$

55. ABCD is a quadrilateral in which $AB = AC$, $AD = CD = 13$ cm, $\angle BAC = 20^\circ$ and $\angle ADC = 100^\circ$. If $BC = 12$ cm, then AB is equal to
 1. 20 cm 2. 25 cm 3. 23 cm 4. 21 cm

Ans. (Bouns)

Sol.

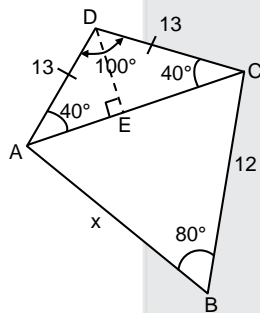

$$\begin{aligned} \text{Let } AC &= x \\ AE &= 13\cos 40^\circ \\ EC &= 13\cos 40^\circ \\ AC &= AE + EC = 26\cos 40^\circ \\ &= 26(0.766) \\ &= 19.916 \end{aligned}$$

Or

$$\begin{aligned} \text{Let } AC &= X \\ \text{In } \triangle ADC & \\ \cos 100^\circ &= \frac{13^2 + 13^2 - x^2}{2 \cdot 13 \cdot 13} \\ \cos 80^\circ &= \frac{12^2 + x^2 - x^2}{2 \cdot 12 \cdot x} = -\cos 100^\circ \\ \frac{13^2 + 13^2 - x^2}{2 \cdot 13 \cdot 13} &= -\left(\frac{12^2}{2 \cdot 12 \cdot x}\right) \\ x^3 - 338x - 2028 &= 0 \end{aligned}$$

No option satisfy equation .
So it is Bonus.

56. In quadrilateral ABCD, $\angle ABC + \angle DCB = 90^\circ$ and ADEF is a square constructed on side AD in the exterior of the quadrilateral ABCD. If BC = 10 cm, AC = 9 cm and BD = 8, then the area (in cm^2) of the square ADEF lies between

1. 70 and 80 2. 60 and 70 3. 50 and 60 4. 40 and 50

Ans. (4)

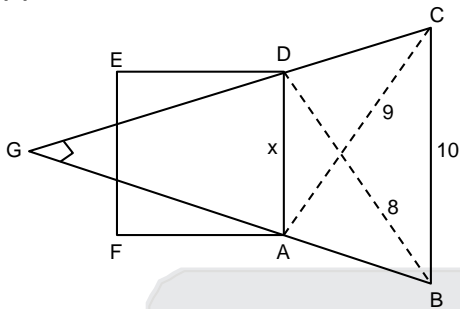

Sol.

$$\begin{aligned} \text{In } \triangle AGD \quad x^2 &= GD^2 + GA^2 && \dots (1) \\ \text{In } \triangle GAC \quad 9^2 &= GC^2 + GA^2 && \dots (2) \\ \text{In } \triangle GDB \quad 8^2 &= GD^2 + DB^2 && \dots (3) \\ \text{In } \triangle GBC \quad 10^2 &= GC^2 + GB^2 && \dots (4) \\ (1) + (4) &= (2) + (3) \\ x^2 + 10^2 &= 9^2 + 8^2 \\ x^2 &= 45 \end{aligned}$$

57. Let G be the centroid of $\triangle ABC$ in which the angle C is obtuse. Let AD and CF are the medians from A and C on the sides BC and AB respectively. if the four points B, D, G and F are concyclic, then BC/AC

1. $> \frac{1}{2}$ 2. $< \frac{1}{\sqrt{2}}$ 3. $> \frac{1}{\sqrt{2}}$ 4. $< \frac{1}{2}$

Ans. (2)

Sol. By Apollonian Theorem

$$\begin{aligned} B^2 + a^2 &= 2 \left(CF^2 + \frac{C^2}{4} \right) \\ CF^2 &= \left[\frac{b^2 + a^2}{2} - \frac{c^2}{4} \right] \dots (1) \end{aligned}$$

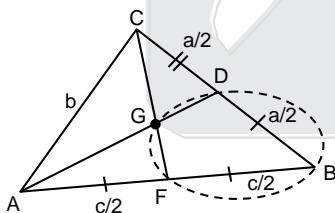

By power point theorem at C.
CD.CB = CG.CF

$$\left(\frac{a}{2} \right) (a) = \frac{2}{3} CF.CF$$

$$\frac{a^2}{2} = \frac{2}{3} CF^2$$

$$3a^2 = 4CF^2$$

Used quation (1)

$$3a^2 = 4 \left[\frac{b^2 + a^2}{2} - \frac{c^2}{4} \right]$$

$$3a^2 = 2(b^2 + a^2) - c^2$$

$$c^2 = 2(a^2 + b^2) - 3a^2$$

as $\triangle ABC$ in obtuse

$$c^2 > a^2 + b^2$$

$$2(a^2 + b^2) - 3a^2 > a^2 + b^2$$

$$2a^2 + 2b^2 - 3a^2 > a^2 + b^2$$

$$b^2 > 2a^2$$

$$\frac{a}{b} < \frac{1}{\sqrt{2}}$$

58. For the distinct real numbers a, b, c and a ≠ 0, consider the quadratic equation $ax^2 + bx + c = 0$. If $a + b + c = 0$; then the solutions of the quadratic equation are :

1. a/b and b/a 2. a/b and b/c 3. 1 and b/a 4. 1 and c/a

Ans. (4)

59. A rectangular plot is of length 28m and width 14m. A conical pit of diameter 7m and depth 3m with its flat surface upward and vertex downward is dug at one corner of the plot. The soil dug out is spread uniformly over the remaining area of the plot. The best approximation value of the increment in the level of the remaining plot is (take $\pi = 22/7$)

- 1.. 10.5 cm 2. 10.9 cm 3. 9.9 cm 4. 9.5 cm

Ans. (2)

Sol.

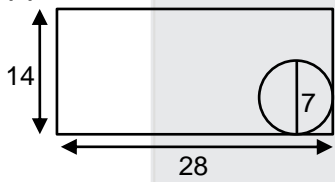

$$\left((28 \times 14) - \pi \left(\frac{7}{2} \right)^2 \right) x = \frac{1}{3} \pi \left(\frac{7}{2} \right)^2 \times 3$$

$$392 - \frac{22}{7} \times \frac{7}{2} \times \frac{7}{2} = \frac{1}{3} \times \frac{22}{7} \times \frac{7}{2} \times \frac{7}{2} \times 3$$

$$\left(392 - \frac{77}{2} \right) x = \frac{1}{3} \times \frac{22}{7} \times \frac{7}{2} \times \frac{7}{2} \times 3$$

$$x = 10.9 \text{ cm}$$

60. The sum of deviations from 50 of n values x_1, x_2, \dots, x_n is -10 and the sum of deviations from 46 of x_1, x_2, \dots, x_n is 70. Then the deviation of the mean of the given values from 48 is

1. 1.5 2. -1.5 3. 2 4. -2.5

Ans. (1)

Sol.

$$x_1 - 50 + x_2 - 50 + \dots + x_n - 50 = -10$$

$$\underbrace{x_1 + x_2 + \dots + x_n - 50n}_{A} = -10$$

$$A - 50n = -10 \quad \dots \dots \dots (1)$$

$$x_1 - 46 + x_2 - 46 + \dots + x_n - 46 = 70$$

$$\underbrace{x_1 + x_2 + \dots + x_n - 46n}_{A} = 70$$

$$A - 46n = 70 \quad \dots \dots \dots (2)$$

$$A - 50n = -10$$

$$A - 46n = 70$$

$$\begin{array}{r} (-) \quad (+) \quad - \\ \hline -4n = -80 \end{array}$$

$$\boxed{n = 20}$$

$$A - 1000 = -10$$

$$A = 990$$

$$\text{Mean} = \frac{990}{20} = 49.5 \quad \Rightarrow \text{Deviation} = 49.5 - 48 = 1.5$$

SOCIAL SCIENCE

61. In modern democracies, political power is distributed. The power-sharing arrangements can take many forms. In the context of India, which statement/s is/are NOT true?

- I. Arrangement of distribution of power between different organs of the government
- II. Arrangement of sharing of power among two or more political parties
- III. Arrangement of the division of power between different religious communities
- IV. Arrangement of the division of power between different levels of the government

1. I and II 2. I, II and IV 3. II only 4. III only

Ans. (4)

62. When no party or coalition gets a majority in the Lok Sabha, the President exercises his/her discretion in the appointment of the Prime Minister. Which of the following statement conveys the correct use of discretion of the President under constitutional provisions?

- 1. The President may appoint the leader of largest majority party in the Lok Sabha as Prime Minister.
- 2. The President appoints leader who in his/her opinion can muster majority support in the Lok Sabha and can prove majority support in the Lok Sabha.
- 3. The President may appoint the senior most member of Lok Sabha as Prime Minister.
- 4. The President may appoint the leader of largest majority party in the Rajya Sabha as Prime Minister.

Ans. (2)

63. Which two among the following are NOT presenting true picture of the Implementation of Panchayati Raj system in India

- A. Panchayati Raj has increased women's representation and voice in Indian democracy,
- B state governments have transferred significant powers to Panchayati Raj institutions;
- C. Panchayati Raj institutions have been given adequate resources;
- D. Panchayati Raj has helped to deepen democracy in our country,

1. A and B 2. B and C C and D 4. D and A

Ans. (2)

64. Caste in politics have both positive and negative aspects. Which among the following is negative effect of caste in Indian Democracy?

- 1. caste politics has helped people from Dalits and OBC castes to gain better access to decision making;
- 2. each caste group tries to become bigger by incorporating within it neighbouring castes or sub-castes which were earlier excluded from it;
- 3. some marginal caste groups have come up in the political arena;
- 4. in some cases caste division leads to tensions, conflict and even violence.

Ans. (4)

65. Michelle Bachelet, who was elected as President in 2006, became the first woman to be a Defence Minister in Latin American country Chile. Before being appointed as Defence Minister, she was -

- 1. a member of the Solidarity Party of Poland;
- 2. a cabinet minister in Pinochet Dictatorship;
- 3. an air force officer during President Pinochet's Military rule;
- 4. a political prisoner during Pinochet Dictatorship.

Ans. (4)

66. Freedom means absence of constraints. In practical life it means absence of interference in our affairs by other - be it other individuals or the government. Under the Indian Constitution citizens do not have one of the following freedoms:

- 1. Freedom of speech and expression;
- 2. Freedom to move freely throughout the country;
- 3. Freedom of assembly in a peaceful manner,
- 4. Freedom to acquire, hold and dispose any property anywhere in the country.

Ans. (4)

67. There are serious challenges that democracy faces throughout the world. Given below are some of the major challenges in Group-I and the respective implications in Group-II in a jumbled up manner. Correctly match the challenges and their implications.

Group-1	Group-II
A Foundational challenge	E. Strengthening of the institutions
B. Challenge of expansion	F. Free and fair elections
C Challenge of deepening of democracy	G. Establishing a sovereign and functional state
D. Procedural challenges	H. Ensuring greater power to local governments

1. (A-E), (B-F), (C-G), (D-H) 2. (A-G), (B-H), (C-E), (D-F)
 3. (A-H), (B-G), (C-F), (D-E) 4. (A-F), (B-G), (C-E), (D-H)

Ans. (2)

68. Constitution is the supreme law that determines the relationship among people living in a territory (called citizens) and also the relationship between the people and government. Which of the following statements is correct?

1. It lays down limits on the powers of the government and tells us what the rights of the citizens are.
 2. It generates a degree of conflict and diversity that is necessary for different kind of people to live together.
 3. It does not specify formation of the government and decision making process.
 4. It will not provide an opportunity to express the aspirations of the people about creating a good society.

Ans. (1)

69. Hannah is attaining the voting age and is happy that she can vote. In her country, citizens can elect representatives but cannot share any observations about the leader of the country. Which of the following democratic rights is restricted for Hannah?

1. Right to equality 2. Right to be treated fairly
 3. Right to freedom 4. Right to information

Ans. (3)

70. Which of the following sets of items are included in the Concurrent List of the Indian Constitution?

- A. Forest, trade unions, marriage, adoption and succession;
 B. Foreign affairs, banking, communications and currency;
 C. Census, railways and space research;
 D. Population control, labour welfare and protection of wild animals.

1. A and B 2. A and C 3. A and D 4. B and D

Ans. (3)

71. A family of four members in Delhi was settled in a slum and earning enough income to lead a subsistence life. They were migrants from a Bihar village in search of employment. During the COVID lockdown, they managed to be in Delhi with the support of Philanthropists and local government. However, they decided to go back to Bihar. They had enough money to buy food for another 10 days. The family decided to travel to Bihar by walk or through whatever transport service they could get. During that travel the family had to stop in various towns and villages for food and shelter. The family could not get enough food in most of the places because (a) restaurants were closed, (b) in some places the distribution of food was made only for the local residents, (c) after nearly 10 days of travel; the family did not have enough money to pay for food. How do you classify these reasons as food insecurity?

1. (a) inaccessibility, (b) non-availability, (c) non-affordability
 2. (a) non-affordability, (b) non-availability, (c) inaccessibility
 3. (a) non-availability, (b) inaccessibility, (c) non-affordability
 4. (a) non-availability, (b) non- affordability, (c) inaccessibility

Ans. (3)

72. I purchased gold jewellery weighing 8 grams from a jeweller. He offered to reduce GST on the jewel if I did not insist on a bill and that I should pay in cash. I agreed. After one year, when I wanted to sell the jewel, at that time, I found that the jewel was not made of 22 carat gold. Which of the following conclusions are correct?
- A. I have no proof of purchase; hence I may not get my grievance addressed.
 B. My statement that I purchased the jewel from a particular seller is enough to get my grievance addressed in a consumer court.
 C. I should not have avoided payment of GST and I should have insisted on getting a bill.
 D. I have facilitated the jeweller to indulge in a series of tax avoidance such as non-payment of input tax and income tax.
1. A, B and C 2. A, C and D 3. B and D only 4. A and B only

Ans. (2)

73. We have given some effects of globalization on developing countries. Classify the positive effects
- (a) Consumers have more choice of commodities, as imports from other countries are easy to access.
 (b) Access to foreign direct investments increases economic activities in sectors wherein the investment flows.
 (c) The unrestricted exposure to western culture is a threat to maintain our cultural objects.
 (d) The native cultures and cuisines are taken to other parts of the world, so our culture spreads to other countries easily.
 (e) We have easy access to foreign markets to market our products.
 (f) Cheap labour in developing countries attracts foreign companies to start production in developing countries.
 (g) Some domestic industries are adversely affected as they could not meet the competition from foreign companies and imported products.
1. (c), (d), (e), (g) 2. (a), (b), (g). (c) 3. (a), (c), (d), (e), (f) 4. (a), (b), (d), (e), (f)

Ans. (4)

74. There are two statements given below marked as Assertion (A) and Reason (R). Read the Statements and choose the correct option.
- Assertion (A): Terms of credit vary substantially from one credit arrangement to another.
 Reasoning (R): Terms of credit vary depending on the nature of lender and the borrower.
1. Both A and R are True and R is the correct explanation of A.
 2. Both A and R are True but R is not the correct explanation of A.
 3. A is True R is False.
 4. A is False and R is True.

Ans. (1)

75.

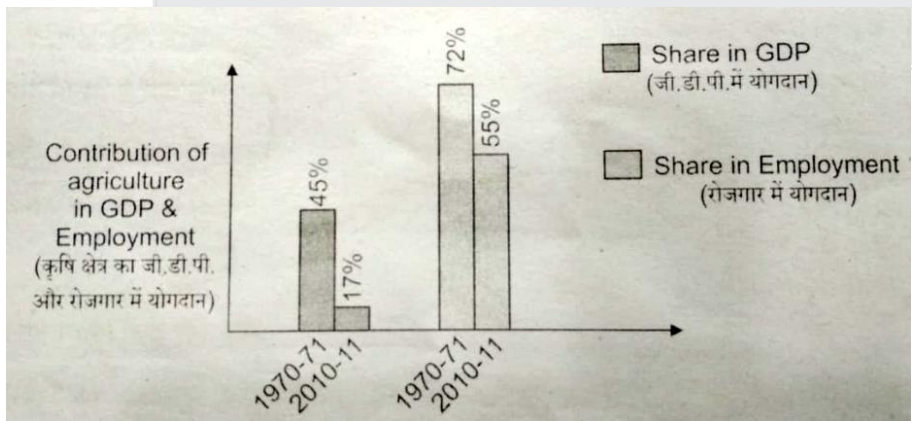

The above graph shows falling share of agricultural sector towards both GDP & employment. Which one is the correct alternative?

1. Fall in productivity of the agricultural workers.
 2. Rise in Productivity of the agricultural workers
 3. No change in productivity of the agricultural workers.
 4. None of the above.

Ans. (1 or 3)

76. Sustainable development can be promoted if:
1. Rate of extraction of renewable resources is less than rate of its regeneration.
 2. Rate of extraction of non-renewable resources is less than rate of creation of its substitutes.
 3. Rate of extraction of renewable resource is less than rate of extraction of non-renewable resources.
 4. Rate of extraction of all resources is less than rate of its regeneration and creation.

Ans. (4)

77. Arrange the following persons in terms of ascending order of vulnerability to poverty that is from the least vulnerable to the most vulnerable.
- (a) Rahul completed 8th standard, and is working as a bus driver in private bus transport company with proper employment order and labour security cover.
- (b) Rithish is graduate and a musician. He earns living through concerts in larger towns and cities all over the country.
- (c) Ramu is an illiterate and agricultural labourer in a village with only dry lands.
- (d) Ramesh can read and write and he is a construction worker employed on daily wage basis by a contractor in a big town.
1. Rahul, Ramu, Ramesh, Rithish
 2. Rithish, Rahul, Ramesh, Ramu
 3. Ramu, Ramesh, Rahul, Rithish
 4. Ramu, Ramesh, Rithish, Rahul

Ans. (2)

78. A carpenter has a workshop near a market place in a small town. He employed two persons A and B on a daily wage. The carpenter is not happy with these two workers. A is irregular, mostly either he comes late or goes home early for some reason, but completes his assigned jobs on time. B is regular but takes double the time as A to complete the job. The carpenter pays same daily wage rate to both. Which of the following suggestion you would recommend to the carpenter?
1. Let the carpenter pay the worker based on the piece job.
 2. Let the carpenter pay on the basis of hours of work so that he can make person A more regular.
 3. Let the carpenter pay only half the salary to person B as he is not as efficient as person A.
 4. Let the carpenter suspend person B and keep person A.

Ans. (1)

79. In a farmer's household in West Bengal, all the adult members were involved in the activities of the household's own farm. The household could earn enough of income to lead a life with basic necessities of life and a little savings to meet emergency expenditures. Last year, the eldest son, aged 40 years was bed-ridden for almost a year due to a serious illness. Hence he could not participate in the household's farming activities. However, the income of the household from agriculture did not decline. How do you call generally the employment of the eldest son on the household's farm:
1. Seasonal unemployment
 2. Under-employment.
 3. Disguised unemployment
 4. Gainful employment.

Ans. (3)

80. When a mobile service customer wants to port out from operator X to operator Y and the former denies permission, then which right is violated ?
1. Right to safety
 2. Right to choose
 3. Right to inform
 4. Right to seek redressal

Ans. (2)

81. Chhattisgarh shares boundaries with six states of India. Which one of the following is correct sequence of the bordering states in clock wise direction starting from Jharkhand?
1. Jharkhand - Odisha - Telangana - Andhra Pradesh - Maharashtra - Madhya Pradesh
 2. Jharkhand - Bihar - Madhya Pradesh - Maharashtra - Odisha - Telangana
 3. Jharkhand - Odisha - Andhra Pradesh - Telangana - Maharashtra - Madhya Pradesh
 4. Jharkhand - Odisha - Telangana - Maharashtra - Madhya Pradesh - Uttar Pradesh

Ans. (3)

82. If you are travelling along 80°E longitude from Uttar Pradesh to Tamil Nadu. You will come across many river basins on your way. Which one of following is the proper sequence of river basins?

1. Ganga - Narmada - Mahanadi - Godavari - Krishna - Palar
2. Ganga - Mahanadi - Narmada - Godavari - Kaveri - Penneru
3. Ganga - Narmada - Mahanadi - Krishna - Penneru - Palar
4. Ganga - Narmada - Godavari - Krishna - Penneru – Palar

Ans. (4)

83. Which one of the following is NOT true about understanding the Indian Monsoon?

1. Low pressure over the Indian land mass and relatively high pressure over the sea
2. Shift of Monsoon trough during summer
3. Formation of high pressure over Tibetan Plateau
4. The presence of easterly jet stream over Indian Peninsula

Ans. (3)

84. Cement industry uses raw materials like limestone, coal and gypsum. Which one of the following states provides suitable environment due to availability of these raw materials along with sufficient electricity for the production of cement?

1. Mizoram
2. Meghalaya
3. Manipur
4. Nagaland

Ans. (2)

85. Read the given statements and select the correct answer.

Statement 1: Laterite soils are formed under the environmental condition of high temperature and heavy rainfall.

Statement 2: Intense leaching results into loss of humus content and lesser presence of micro-organisms in the soil.

1. Statement 1 is true, statement 2 is false.
2. Statement 1 is false, statement 2 is true.
3. Both statements are true and statement 1 provides explanations for statement 2.
4. Both statements are true and statement 1 does not provide explanations for statement 2.

Ans. (3)

86. Which of the following is NOT true about sea ports of India?

1. Vishakhapatnam is the deepest land locked and well developed port.
2. Chennai is an inland riverine port.
3. Mumbai is the biggest port with spacious natural and well developed harbour.
4. Tuticorin port in Tamil Nadu has a natural harbour and rich hinterland.

Ans. (2)

87. If the opening time for the central schools in India is 7:30 am IST, what will be local time at Ziro 94° East Longitude and Sihor at 72° East Longitude, respectively?

1. 8:26 am - 6:54 am
2. 8:20 am - 6:50 am
3. 8:16 am - 6:48 am
4. 8:10 am - 6:40 am

Ans. (3)

88. Read the given statements and select the correct answer:

Statement 1: Expansion of railways, plantation agriculture, commercial and scientific forestry and mining activities were largely responsible for the depletion of forests and wildlife during colonial period.

Statement 2: Unequal access, inequitable, consumption of resources and differential sharing of responsibility for environmental wellbeing are the cause for the depletion of biodiversity.

1. Statement 1 is true, statement 2 is false.
2. Statement 1 is false, statement 2 is true.
3. Both statements are True and statement 2, provide explanation for statement 1.
4. Both statements are True and statement 2 does not provide explanation for statement 1.

Ans. (4)

89. What is common factor among Wular Lake, Harike, Sambhar Lake and Keibul Lamjao?
 1. Wild life sanctuary 2. Wetlands 3. National Park 4. Biosphere reserves

Ans. (2)

90. Column-I in the following table indicates the states of India and Column-II the sex ratio (females/per 1000 males) in 2011 census. Which one of the following is proper combination?

	Column-I (States)		Column-II (Sex Ratio 2011)
A	Tamil Nadu	1	950
B	West Bengal	2	931
C	Maharashtra	3	996
D	Madhya Pradesh	4	929

- Ans. (4) 1. A2, B4, C1, D3 2. A1, B3, C2, D4 3. A4, B2, C3, D1 A3, B1, C4, D2

91. Which of the following changes were brought about by the Bolsheviks immediately after the October Revolution?
 I. Most industries and banks were nationalized in November 1917.
 II. Land was declared social property and peasants were allowed to seize the land of the nobility.
 III. In villages, Bolsheviks enforced the integration of large houses with no regard for family requirements.
 IV. New uniforms were designed for the army and officials.

- Ans. (4) 1. I, II and III 2. I, III and IV 3. II, III and IV 4. II and IV

92. Which of the following statements is incorrect about the portrayal of Marianne and Germania?
 I. France's female allegory, Marianne, underlined the idea of a people's nation.
 II. Marianne's characteristics were drawn from those of Liberty and the Republic – the red cap, the tricolour, the cockade.
 III. Germania became the allegory of the German nation.
 IV. Germania wears a dress of oak leaves, as these leaves stand for peace.

- Ans. (4) 1. I 2. II 3. III 4. IV

93. From the following, identify to correct statements relating to indentured labour migration from India.
 I. In the nineteenth century, thousands of Indian labourers went to work in plantations, mines, and road and railway construction projects around the world.
 II. Most of the indentured labour came from present day regions of northern and western India such as Punjab, Haryana, Gujarat, and Rajasthan.
 III. The Indentured network which has often been described as a 'new system of slavery' for the labourers found the most pathetic and terrible conditions of living and working on their arrival in places like the Caribbean Islands, Mauritius, Fiji, Ceylon, and Malaya.
 IV. Some indentured labourers found innovative ways of expressing themselves by blending their own cultural ethos with that of the new place.

- Ans. (3) 1. II, III and IV 2. I, II and III 3. I, III and IV 4. I, II and IV]

94. Which of the following statements about the lives of workers in early nineteenth century England are true?
 I. Not all of them had access to jobs in the city as urban employment still depended on social and familial connections.
 II. Work was largely seasonal which meant the poor had to return to the streets or to the countryside whenever the busy season was over.
 III. They welcomed the introduction of new technology such as the Spinning Jenny as they thought that their work would become easier with the new device.

IV. Even as daily wages increased the impact was mitigated on account of small number of days for which most of them were employed.

1. I, II and III 2. I, III and IV 3. II, III and IV 4. I, II and IV

Ans. (4)

95. With regard to the relationship between print culture and the French Revolution. which of the following statements are true?

- I. Print culture caused the ideas of the Enlightenment reason and rationality to reach a large number of people which weakened the authority of the Church and the power of the state.
 II. By the 1780s, there was an outpouring of literature that mocked the royalty and criticized their morality.
 III. Print created a new culture of dialogue and debate that made people re-evaluate their long-held views, beliefs and assumptions.
 IV. Print culture spread in a way that it did not at all become the means for the expression of monarchical and Church propaganda.

1. I, III and IV 2. I, II and III 3. II, III and IV 4. I, II and IV

Ans. (2)

96. Which of the following were associated with the Non-Cooperation Movement?

- I. It was the first movement started by Mahatma Gandhi.
 II. Indian institutions were created to replace British administration.
 III. It called for total boycott of all arms of British administration by the Indians.
 IV. Khilafat movement also began with this movement.

1. I and II 2. II and IV 3. III and IV 4. I, III and IV

Ans. (3)

97. Assertion (A): Civil Disobedience Movement could not get the support of all sections of the society. Reason (R): 'Untouchables' were not moved by the concept of Swaraj.

1. A is true, R is false.
 2. A is false, R is true.
 3. Both A and R are true, but R is not the correct explanation of A.
 4. Both A and R are true, and R is the correct explanation of A.

Ans. (4)

98. The first world war was an unusual war because:

- I. It involved the world's leading industrial nations.
 II. Weapons of mass destruction were used at a large scale.
 III. British policies were responsible for the outbreak of the war.
 IV. The world was divided into two power blocks.

1. I and II 2. II, III and IV 3. III and IV 4. I, II and IV

Ans. (4)

99. The concept of 'Lebensraum' as propounded by Nazism was related to:

- I. Enunciation of the principle of social superiority of the Aryans.
 II. Throwing away of the 'undesirable children' out of schools.
 III. Treating mothers as the most important citizens.
 IV. Acquiring new territories to enhance the area of the mother country.

1. I 2. II 3. III 4. IV

Ans. (4)

100. Which of the following statements related to the ideas of Liberalism in nineteenth century Europe are correct?

- I. Freedom for the individual and equality of all before the law.
 II. Concept of Government by consent.
 III. Universal suffrage.
 IV. Freedom of markets.

1. I, II and III 2. I, II and IV 3. I, III and IV 4. II, III and IV

Ans. (2)

BEST RANK
from **Kota Classroom**
among all Institutes of Kota

Congratulations!!!

Thanks students / parents for
your continued trust...

P : 110
C : 114
M : 100
Total 324 / 360



CHAITANYA AGGARWAL
Reso Roll No.: 20222679
Classroom Student

9 ALL INDIA RANKS IN TOP-200 FROM CLASSROOM



ANKAN SARKAR
Reso Roll No.: 19156896



KUSHAGRA GUPTA
Reso Roll No.: 19150149



MONIL LODHA
Reso Roll No.: 15435885



UJJAYAN PAL
Reso Roll No.: 19178025



HARSH BIHANI
Reso Roll No.: 191606257



SWASTIK SINGHAL
Reso Roll No.: 18228132



ADITYA KUMAR
Reso Roll No.: 19172646



AKSHAT RAJANI
Reso Roll No.: 17403501

OTHER HIGHLIGHTS

126 Girls
Selections from Classroom

59 विद्यार्थी
(नियमित क्लासरूम पाठ्यक्रम)
हिन्दी माध्यम से

ADMISSIONS OPEN
for Session 2021-22 & 2022-23

Classes: 5 to 12 & 12+

Target: JEE (Advanced) | JEE (Main) | NEET (UG)
Pre-Foundation | CA/CS | CLAT | Boards

VIJAY PLUS

5 Month Power Packed Course

for JEE (Advanced) 2022

Starts from 25th Oct. | 11th & 15th Nov. 2021

Scholarship upto 90%*



Scan QR for Apply

Resonance Eduventures Ltd.

Kota Study Centre & Registered Corporate Office: CG Tower, A-46 & 52, IPIA, Near City Mall, Jhalawar Road, Kota (Raj.) - 324005
Tel. No.: 0744-2777777, 2777700 | CIN: U80302RJ2007PLC024029 | Visit: www.resonance.ac.in

 **1800 258 5555**

 facebook.com/ResonanceEdu

 twitter.com/ResonanceEdu

 www.youtube.com/resowatch

 blog.resonance.ac.in