



ENGLISH - HINDI	<div style="border: 1px solid black; display: inline-block; padding: 5px;"> 13-15 </div> Code
------------------------	---

Roll No.	रोल नंबर
<div style="border: 1px solid black; display: inline-block; width: 100%; height: 20px;"></div>	<div style="border: 1px solid black; display: inline-block; width: 100%; height: 20px;"></div>
Booklet Number	पुस्तिका संख्या
<div style="border: 1px solid black; display: inline-block; padding: 5px;"> 152104 </div>	

SCHOLASTIC APTITUDE TEST
(For Students of Class X)

Time: 120 Minutes Max. Marks: 100

INSTRUCTIONS TO CANDIDATES

Read the following instructions carefully before you open the Test booklet.

1. Answers are to be given on a separate OMR sheet.
2. There are 100 questions in this test. All are compulsory. The question numbers 1 to 40 belong to Sciences, 41 to 60 pertain to Mathematics and 61 to 100 are on Social Science subjects.
3. Please follow the instructions given on the OMR sheet for marking the answers.
4. Write your eight-digit Roll Number as allotted to you in the admission card clearly on the test-booklet and darken the appropriate circles on the OMR sheet as per instructions given.
5. Write down and darken Test Booklet Number in the appropriate circles on the OMR sheet as per instructions given.
6. Since the time allotted for this question paper is very limited and all questions carry equal marks, you should make the best use of it by not spending too much time on any one question.
7. Rough work can be done anywhere in the booklet but not on the OMR sheet/loose paper.
8. Each correct answer will be awarded one mark.
9. **THERE WILL BE NO NEGATIVE MARKING.**
10. Please return only the OMR sheet to the invigilator after the test.
11. English version of the question paper will be considered as final in case of any dispute arising out of variation in translation.

Please turn over the page and start answering immediately after you are asked to do so.

शैक्षिक अभिज्ञता परीक्षा

(कक्षा X के विद्यार्थियों के लिए)

समय: 120 मिनट अधिकतम अंक: 100

परीक्षार्थियों के लिए अनुदेश

प्रश्न-पुस्तिका खोलने से पहले, निम्नलिखित अनुदेशों को ध्यान से पढ़िए।

1. उत्तर एक अलग ओएमआर-पत्र पर देने हैं।
2. इस परीक्षा में 100 प्रश्न हैं। सभी प्रश्न अनिवार्य हैं। प्रश्न 1 से 40 विज्ञान, 41 से 60 गणित और 61 से 100 सामाजिक विज्ञान के विषयों पर आधारित हैं।
3. कृपया उत्तर चिह्नित करने के लिए ओएमआर-पत्र पर दिए गए निर्देशों का अनुपालन कीजिए।
4. दिए गए निर्देशों के अनुसार आपके प्रवेश पत्र पर दिए गए अपने आठ-अंकीय रोल नंबर को प्रश्न-पुस्तिका और ओएमआर-पत्र पर बिल्कुल स्पष्ट रूप से लिखिए और उपयुक्त गोलों को काला कीजिए।
5. दिए गए निर्देशों के अनुसार ओएमआर-पत्र पर प्रश्न-पुस्तिका संख्या लिखिए और उपयुक्त गोलों को काला कीजिए।
6. चूंकि इस प्रश्न-पत्र के लिए निर्धारित समय बहुत सीमित है, और सभी प्रश्नों के समान अंक हैं, इसलिए समय का अधिकतम उपयोग कीजिए और किसी प्रश्न पर बहुत अधिक समय न लगाइए।
7. रफ कार्य पुस्तिका में कहीं भी किया जा सकता है, किंतु ओएमआर-पत्र / अलग कागज पर नहीं।
8. प्रत्येक सही उत्तर के लिए एक अंक प्रदान किया जाएगा।
9. गलत उत्तर के लिए कोई अंक नहीं काटा जाएगा।
10. कृपया परीक्षा के पश्चात केवल ओएमआर-पत्र ही परीक्षक को वापस कीजिए।
11. अनुवादित संस्करण में अंतर से उठे किसी भी विवाद की स्थिति में, प्रश्न-पत्र के अंग्रेजी संस्करण को निर्णायक माना जाएगा।

जैसे ही आपसे कहा जाए, वैसे ही कृपया पृष्ठ पलटिए और अपना कार्य आरंभ कीजिए।

NCERT 2018

The copyright of the contents of this booklet rests with the NCERT and no part of it should be used by anybody in any manner whatsoever without the prior permission of the NCERT. The items are prepared with best expertise. In case of any dispute the opinion of the experts appointed by NCERT will be final.

SCHOLASTIC APTITUDE TEST (SAT) PAPER

1. Under which condition stated below, the six carbon glucose molecule is broken down into three carbon molecules pyruvate and lactic acid ?
 1. Aerobic condition in muscle cells
 2. Anaerobic condition in yeast cells
 3. Aerobic condition in mitochondria
 4. Anaerobic condition in muscle cells

2. Which among the following is the correct sequence regarding the flow of impulse in a neuron.
 1. Dendrite → Axon → Cell body
 2. Axon → Cell body → Dendrite
 3. Axon → Dendrite → Cell body
 4. Cell body → Axon → Nerve terminal

3. In a hypertensive patient, the systolic pressure increased to 150 mm of Hg. Which part of the brain would be involved in the regulation of blood pressure ?
 1. Medulla
 2. Cerebrum
 3. Cerebellum
 4. Hypothalamus

4. Edward Jenner's contribution for the eradication of small pox is
 1. His proposition that small pox had possibly spread throughout the world from India and China.
 2. His discovery of transformation procedure.
 3. His finding that rubbing of the skin crust of small pox victims on the arm of a healthy person, would develop resistance against small pox.
 4. His finding that the cow pox infection protects the person from subsequent infection from small pox.

5. Four important events given below may have led to the origin of life on the earth.
 - I. Formation of amino acids and nucleotides
 - II. Availability of water
 - III. Organization of Cells
 - IV. Formation of complex molecules
 1. I, II, III and IV
 2. II, I, IV and III
 3. I, IV, II and III
 4. II, III, I and IV

6. Read the following statements carefully.
 - I. Energy transfer in the biotic world always proceeds from the autotrophs.
 - II. Energy flow is unidirectional.
 - III. Energy availability is maximum at the tertiary level.
 - IV. There is loss of energy from one trophic level to the other.

Select the relevant statements for the forest ecosystem

 1. I, II, and IV
 2. I, II and III
 3. I, III and IV
 4. II, III and IV

7. In a highly pesticide polluted pond. Which of the following aquatic organisms will have the maximum amount of pesticide per gram of body mass?
 1. Lotus
 2. Fishes
 3. Spirogyra
 4. Zooplanktons



8. A farmer made an observation in a backwater paddy field of coastal Kerala that the paddy plants wilt during noon onwards everyday but appear normal next morning. What would be the possible reason for wilting?
1. The rate of water absorption is less than the rate of transpiration in the afternoon.
 2. The rate of water absorption is more than the rate of transpiration in the afternoon.
 3. The changes in the rate of water absorption and transpiration are not associated with wilting.
 4. The rate of water absorption is not related to the rate of transpiration.

9. Observe the experimental sets [A] & [B]

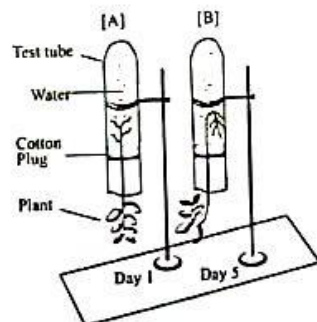

Observe the test tube A & B. From the list given below, choose the combination of responses of shoot and root that are observed in B.

1. Positive phototropism and positive geotropism
 2. Negative phototropism and positive geotropism
 3. Positive phototropism and negative geotropism
 4. Only negative phototropism
10. Raw banana has bitter taste, while ripe banana has sweet taste. It happens because of the conversion of
1. Starch to sugar
 2. Sucrose to fructose
 3. Amino acids to sugar
 4. Amino acids to protein
11. In the flowering plants sexual reproduction involves several events beginning with the bud and ending in a fruit. These events are arranged in four different combinations. Select the combination that has the correct sequence of events.
1. Embryo, zygote, gametes, fertilization.
 2. Gametes, fertilization, zygote, embryo.
 3. Fertilization, zygote, gametes, embryo.
 4. Gametes, zygote, embryo, fertilization.
12. In pea plants, Round (R) and Yellow (Y) features of seeds are dominant over wrinkled (r) and green (y) features. In a cross between two plants having the same genotypes (RrYy). the following genotypic combinations of offspring are noticed.
- A- RrYY
B- Rryy
C- rrYy
D- rryy
- The phenotypic features of A, B, C, and D are given below in an order in four combinations. Select the correct combination of characters that corresponds to the genotypes.
1. Round & yellow; round & green; wrinkled & yellow; wrinkled & green."
 2. Round & green; wrinkled & yellow; wrinkled & green; round & yellow.
 3. Wrinkled & green; round & yellow; wrinkled & yellow; round & green.
 4. Wrinkled & yellow; round & green; wrinkled & yellow; round & yellow.
13. Eukaryotic organisms have different levels of organization. Select the combination where the levels are arranged in the descending order.
1. DNA, chromosome, cell, nucleus, tissue
 - 2 Tissue, cell, nucleus, chromosome, DNA
 3. Nucleus, cell, DNA. chromosome, tissue
 4. Tissue, cell, chromosome, nucleus, DNA

14. The gaseous byproduct of a process in plants is essential for another vital process that releases energy. Given below are four combinations of processes and products. Choose the correct combination.
1. Photosynthesis and oxygen
 2. Respiration and carbon dioxide
 3. Transpiration and water vapour
 4. Germination and carbon dioxide
15. 100 grams of oxygen (O₂) gas and 100 grams of helium (He) gas are taken in separate containers of equal volume at 100°C. Which one of the following statement is correct?
1. Both gases would have the same pressure.
 2. The average kinetic energy of O₂ molecules is greater than that of He molecules.
 3. The pressure of He gas would be greater than that of the O₂ gas.
 4. The average kinetic energy of He and O₂ molecules is same.
16. At 298 K and 1 atm pressure. a gas mixture contains equal masses of He, H₂, O₂ and NH₃. Which of the following is correct for their average molecular velocities?
1. He > H₂ > NH₃ > O₂
 2. He < H₂ < O₂ < NH₃
 3. H₂ < He < NH₃ < O₂
 4. O₂ < NH₃ < He < H₂
17. A test tube along with calcium carbonate in it initially weighed 30.08g. A heating experiment was performed on this test tube till calcium carbonate completely decomposed with evolution of a gas. Loss of weight during this experiment was 4.40g. What is the weight of the empty test tube in this experiment?
1. 20.08 g
 2. 21.00 g
 3. 24.50 g
 4. 2.008g
18. Match List I (Mixture to be separated) with the List II (Method used) and select the correct option using the codes given below

List I (Mixture to be separated)	List II (Method used)
A. Petroleum products	I. Chromatography
B. Camphor and rock salt	II. Centrifugation
C. Cream from milk	III. Sublimation
D. Coloured components in a dye	IV. Fractional distillation

1. A-I, B-II, C-III, D-IV
2. A-II, B-IV, C-III, D-I
3. A-IV, B-III, C-I, D-II
4. A-IV, B-III, C-II, D-I

19. In the balanced chemical equation :
 (a lead nitrate + b aluminium chloride → aluminium c nitrate + d lead chloride)
 Which of the following alternative is correct.
1. a = 1, b = 2, c = 2, d = 1
 2. a = 4, b = 3, c = 3, d = 4
 3. a = 2, b = 3, c = 2, d = 3
 4. a = 3, b = 2, c = 2, d = 3
20. The correct order of increasing number of alpha particles passing undeflected through the foils of Au, Ag, Cu and Al of 1000 atoms thickness each in a simulated alpha particle scattering experiment of Rutherford would be
1. Au < Ag < Cu < Al
 2. Al < Cu < Ag < Au
 3. Au < Cu < Al < Ag
 4. Ag < Cu < Al < Au
21. The correct order of increasing pH values of the aqueous solutions of baking soda, rock salt, washing soda and slaked lime is
1. Baking Soda < Rock Salt < Washing Soda < Slaked lime
 2. Rock Salt < Baking Soda < Washing Soda < Slaked lime
 3. Slaked lime < Washing Soda < Rock Salt < Baking Soda
 4. Washing Soda < Baking Soda < Rock Salt < Slaked lime



22. How many grams of oxygen gas will be needed for complete combustion of 2 moles of 3rd member of alkyne series ?
1. 186 g 2. 256 g 3. 352 g 4. 372 g

23. Match List I (Position of the metal in the Activity Series) with the List II (Related Reduction Process) and Select the correct option using the codes given below.

List (Position of the Metal in the Activity Series)	List - II (Related Reduction Process)
A. The bottom of the series	I. Electrolysis
B. The top of the series	II. Reduction by heat alone
C. The lower regions of the series	III. Found in native state
D. The middle of the series	IV. Reduction using carbon or some other reducing agent

1. A - II B - III C-IV D-I
 2. A-II B- I C- IV D- III
 3. A- III B - I C- II D- IV
 4. A- III B - I C-IV D-II

24. Which of the following statement can help a chemistry student to predict chemical properties of an element?
- I. Position of element in the periodic table
 II. Atomic number of the element
 III. Number of shells in the atom
 IV. Number of electron in the outer most shell

1. I, II and III 2. I, II and IV 3. I, III and IV 4. II, III and IV

25. Consider the elements A, B, C and D with atomic numbers 6, 7, 14 and 15, respectively. Which of the following statements are correct concerning these elements?
- I. D will lose electron more easily than C.
 II. B will gain electron more easily than C.
 III. The element with highest electronegativity is D.
 IV. The element with largest atomic size is C.

1. I and II 2. II and III 3. II and IV 4. III and IV

26. A hydrocarbon 'A' (C₃H₅) on treatment with chlorine in presence of sunlight yielded compound 'B' as major product Reaction of 'B' with aqueous KOH gave 'C' which on treatment with concentrated H₂SO₄ yielded 'D'. Hydrogenation of 'D' gave back 'A'. The sequence of reactions involved in above consersion is :

1. Substitution, Substitution, Addition, Dehydration
 2. Substitution, Substitution , Dehydration, Addition
 3. Substitution, Dehydration, Addition, Addition,
 4. Addition, Substitution, Dehydration, Substitution.

27. An organic liquid 'A' with acidified potassium dichromate gave product 'B'. The compound 'B' on heating with methanol in presence of concentrated sulphuric acid formed compound 'C' which on subsequent treatment with sodium hydroxide formed two product 'D' and 'E'. The product 'D' is known to affect the optic nerve causing blindness. Intake of 'D' in very small quantities can cause death. What are compound 'A', 'B', 'C', 'D' and 'E'?

1. A = Ethanol, B = Ethanoic acid, C = Methanol D = Sodium acetate, E = Methyl ethanoate
 2. A = Ethanol, B = Ethanoic acid, C = Methyl ethanoate D = Methanol, E = Sodium acetate
 3. A = Sodium acetate, B = Ethanoic acid, C = Methyl ethanoate, D = Methanol, E = Ethanol
 4. A = Ethanol, B = Ethanoic acid, C = Methyl ethanoate , D = Sodium acetate, E = Methanol



28. Two nichrome wires A and B, each of length 5cm and of radius 1cm and 3cm respectively are connected to each other in series. If a current of 5 A flows through the combination of wires, the ratio of potential difference across wire A to that across wire B will be:
 1. 1 : 3 2. 3 : 1 3. 9 : 1 4. 1 : 9

29. Two convex lenses A and B each of focal length 30cm are separated by 30cm, as shown in the figure. An object O is placed at a distance of 40cm to the left of lens A.

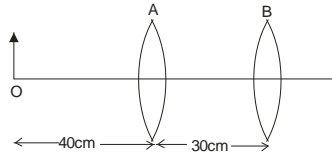

What is the distance of the final image formed by this lens system?

1. 120cm to right of lens A 2. 90cm to right of lens A
 3. 22.5cm to right of lens B 4. 45cm to right of lens B
30. A cart of mass M moves at a speed u on a frictionless surface. At regular intervals of length L, blocks of mass $m = \frac{M}{2}$ drops vertically into the cart. How much time is taken to cover a distance of $\frac{9}{2}L$?
 1. $\frac{9L}{2u}$ 2. $\frac{5L}{2u}$ 3. $\frac{19L}{2u}$ 4. $\frac{17L}{2u}$
31. A ball is thrown vertically up from the point A (see figure). A person, standing at a height H on the roof of a building, tries to catch it, He misses the catch, the ball overshoots and simultaneously the person starts a stop-watch. The ball reaches its highest point and he manages to catch it upon its return. By this time, a time interval T has elapsed as recorded by the stop-watch. If g is the acceleration due to gravity at this place, the speed with which the ball was thrown from point A will be:

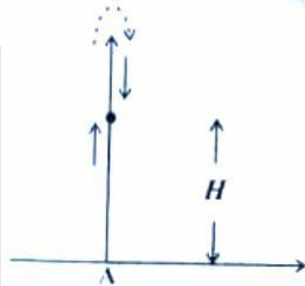

1. $\sqrt{gH} + gT$ 2. $(\sqrt{g^2T^2 + 4gH})/2$ 3. $(\sqrt{g^2T^2 + 8gH})/2$ 4. $(\sqrt{g^2T^2 + 2gH})$

32. A ray of light of pure single colour is incident on the face of a prism having angle of the prism 30° at an angle of incidence 45° . The refracted ray does not change its direction as it crosses the other face and emerges out of the prism. The refractive index of the material of the prism is:
 1. $2/\sqrt{3}$ 2. 2 3. $\sqrt{2}$ 4. $\sqrt{3}$

33. A metallic cubical solid block of side L is slowly lowered continuously in a large vessel, filled with water. Let d be the depth of the lower surface of the block, measured from the surface of the water, at some instant. The graph which represents correctly the variation of the buoyant force F with depth d is:

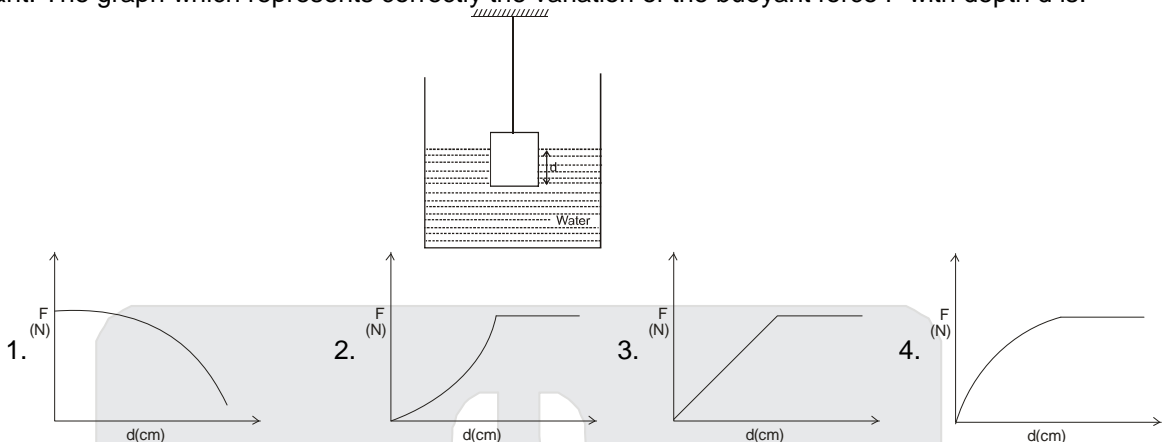

34. Three balls A, B and C of same size but of different masses, are thrown with the same speed from the roof of a building, as shown in figure. Let v_A , v_B and v_C be the respective speeds with which the balls A, B, and C hit the ground. Neglecting air resistance, which one of the following relations is correct?

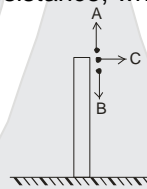

- $v_A > v_C > v_B$
 - $v_C > v_A > v_B$
 - $v_A > v_B > v_C$
 - $v_A = v_B = v_C$
35. Four blocks of different masses ($m_1 = 1\text{kg}$, $m_2 = 2\text{kg}$, $m_3 = 1\text{kg}$ and $m_4 = 5\text{kg}$) are connected with light, inextensible strings, as shown in figure. This system is pulled along a frictionless surface by a horizontal force of 36 N. The force pulling the block of mass m_1 will be:

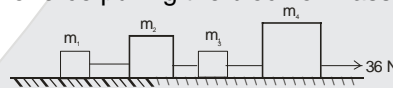

- 2N
 - 4 N
 - 12 N
 - 36 N
36. The velocity-time graph of motion of two cars A and B is shown in the figure

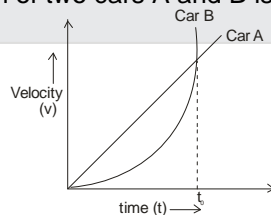

Choose the correct statement.

- Accelerations of two cars are equal to each other at time $t = t_0$
 - Accelerations of two cars are equal to each other at an instant greater than t_0
 - Accelerations of two cars are equal to each other at an instant earlier than t_0
 - At no instant in the interval $0 \leq t \leq t_0$, the two accelerations are equal.
37. Three electric bulbs of rating 40 W – 200 V; 50 W – 200 V and 100 W – 200 V are connected in series to a 600 V supply. What is likely to happen as the supply is switched on?
- Only 50 W bulb will fuse
 - Both 40 W and 50 W bulbs will fuse.
 - All the three bulbs will emit light with their rated powers.
 - 100 W bulb will emit light of maximum intensity.

38. A sound wave is sent simultaneously through a long hollow pipe AB and a solid pipe CD of same length and having same cross-sectional area. A person standing at point P as shown in the figure will hear the sound.



1. at the same time from pipes, AB and CD
 2. First from pipe CD and then from pipe AB
 3. first from pipe AB and then from pipe CD
 4. From pipe AB only and not from pipe CD
39. Two long current-carrying parallel wires are placed as shown.

Which of the following figures will represent the magnitude and direction of the forces exerted on the wires?

1.

2.

3.

4.

40. An electrical circuit, shown below, consists of a battery, an ammeter, three resistors and two keys.

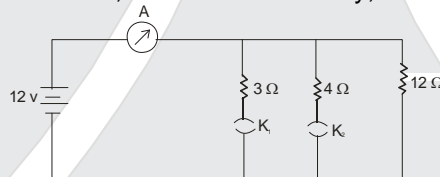

Consider two cases:

- (i) The key K_1 is closed and the key K_2 is open.
 (ii) The key K_2 is closed and the key K_1 is open.

The ratio of respective currents in those two cases will be:

1. 3 : 4
 2. 4 : 3
 3. 4 : 5
 4. 5 : 4
41. Given that $\frac{1}{7} = 0.\overline{142857}$, which is a repeating decimal having six different digits. If x is the sum of such

first three positive integers n such that $\frac{1}{n} = 0.\overline{abcdef}$, where a, b, c, d, e and f are different digits, then the value of x is

1. 20
 2. 21
 3. 41
 4. 42
42. Which of the following digits is ruled out in the units place of $12^n + 1$ for every positive integer n ?
 1. 1
 2. 3
 3. 5
 4. 7
43. The rational roots of the cubic equation $x^3 + 14kx^2 + 56kx - 64k^3 = 0$ are in the ratio 1 : 2 : 4. The possible values of k are
 1. 0 only
 2. 1 only
 3. 2, 0
 4. -2, -1
44. The odd natural numbers have been divided in groups as (1,3) ; (5,7,9,11) ; (13,15,17,19,21,23),..... Then the sum of numbers in the 10th group is
 1. 4000
 2. 4003
 3. 4007
 4. 4008

45. If the polynomial $x^4 - 6x^3 + 16x^2 - 25x + 10$ is divided by another polynomial $x^2 - 2x + k$, the remainder comes out to be $x + a$, then the value of a is
1. -1 2. -5 3. 1 4. 5
46. The values of k , so that the equations $2x^2 + kx - 5 = 0$ and $x^2 - 3x - 4 = 0$ have one root in common, are
1. 3, $\frac{27}{2}$ 2. 9, $\frac{27}{4}$ 3. -3, $\frac{-27}{4}$ 4. -3, $\frac{4}{27}$
47. The value of $\cos x^\circ - \sin x^\circ$ ($0 \leq x < 45$) is
1. 0 2. positive
3. negative 4. sometimes negative and sometimes positive
48. A vertical pole of height 10 metres stands at one corner of a rectangular field. The angle of elevation of its top from the farthest corner is 30° , while that from another corner is 60° . The area (in m^2) of rectangular field is
1. $\frac{200\sqrt{2}}{3}$ 2. $\frac{400}{\sqrt{3}}$ 3. $\frac{200\sqrt{2}}{\sqrt{3}}$ 4. $\frac{400\sqrt{2}}{\sqrt{3}}$
49. A circle is inscribed in a square and the square is circumscribed by another circle. What is the ratio of the areas of the inner circle to the outer circle?
1. 1:2 2. 1 : $\sqrt{2}$ 3. $\sqrt{2} : 4$ 4. 1 : $\sqrt{3}$
50. The surface of water in a swimming pool, when it is full of water, is rectangular with length and breadth 36m and 10.5 m respectively. The depth of water increases uniformly from 1m at one end to 1.75 m at the other end. The water in the pool is emptied by cylindrical pipe of radius 7cm at the rate of 5km/h. The time (in hours) to empty water in the pool is (take $\pi = \frac{22}{7}$)
1. $6\frac{1}{4}$ 2. $6\frac{1}{2}$ 3. $6\frac{3}{4}$ 4. $6\frac{4}{5}$
51. There is a right circular cone of height h and vertical angle 60° . A sphere when placed inside the cone, it touches the curved surface and the base of the cone. The volume of sphere is
1. $\frac{4}{3}\pi h^3$ 2. $\frac{4}{9}\pi h^3$ 3. $\frac{4}{27}\pi h^3$ 4. $\frac{4}{81}\pi h^3$
52. A sealed bottle containing some water is made up of two cylinders A and B of radius 1.5cm and 3cm respectively, as shown in the figure. When the bottle is placed right up on a table, the height of water in it is 15cm, but when placed upside down the height of water is 24cm. The height of the bottle is
1. 25 cm 2. 26 cm 3. 27 cm 4. 28 cm

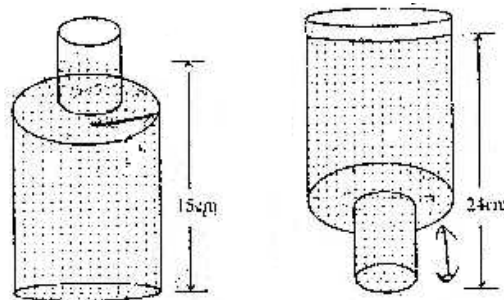

53. Let ℓ be the length of each equal side of an isosceles triangle. If the length of each equal side is doubled, keeping its height unchanged, then the difference of the squares of bases of the new triangle and the given triangle is
1. 0 2. $4\ell^2$ 3. $9\ell^2$ 4. $12\ell^2$

54. In the adjoining figure, ABC is a triangle in which $\angle B = 90^\circ$ and its incircle C_1 has radius 3. A circle C_2 of radius 1 touches sides AC, BC and the circle C_1 . Then length AB is equal to

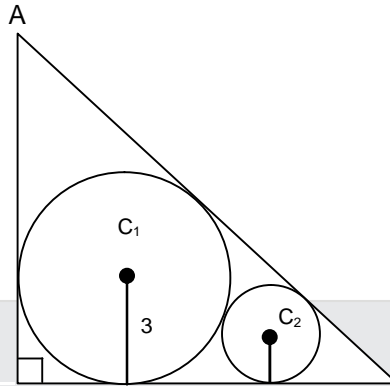

1. $3 + 6\sqrt{3}$ 2. $10 + 3\sqrt{2}$ 3. $10 + 2\sqrt{3}$ 4. $9 + 3\sqrt{3}$
55. In $\triangle ABC$, $AB = AC$, P and Q are points on AC and AB respectively such that $BC = BP = PQ = AQ$. Then $\angle AQP$ is equal to (use $\pi=180^\circ$)
1. $\frac{2\pi}{7}$ 2. $\frac{3\pi}{7}$ 3. $\frac{4\pi}{7}$ 4. $\frac{5\pi}{7}$
56. A line from one vertex A of an equilateral $\triangle ABC$ meets the opposite side BC in P and the circumcircle of $\triangle ABC$ in Q. If $BQ=4\text{cm}$ and $CQ=3\text{cm}$, then PQ is equal to
1. 7 cm 2. $\frac{4}{3}$ cm 3. $\frac{12}{7}$ cm 4. 2 cm
57. How many points (x,y) with integral co-ordinates are there whose distance from (1,2) is two units ?
1. one 2. two 3. three 4. four
58. If the vertices of an equilateral triangle have integral co-ordinates, then
1. such a triangle is not possible 2. the area of the triangle is irrational
3. the area of the triangle is an integer
4. the area of the triangle is rational but not an integer.
59. A box contains four cards numbered as 1,2,3 and 4 and another box contains four cards numbered as 1,4,9 and 16. On card is drawn at random from each box. What is the probability of getting the product of the two numbers so obtained , more than 16 ?
1. $\frac{5}{8}$ 2. $\frac{1}{2}$ 3. $\frac{3}{8}$ 4. $\frac{1}{4}$
60. The mean of a group of eleven consecutive natural numbers is m. What will be the percentage change in the mean when next six consecutive natural numbers are included in the group ?
1. m% 2. $\frac{m}{3}$ % 3. $\frac{m}{300}$ % 4. $\frac{300}{m}$ %
61. The Swaraj flag designed by Mahatma Gandhi had the spinning wheel in it. What did it symbolize?
1. Ideal of self - help
2. Symbol of defiance to the British rule.
3. Greatness of India in pre-colonial time
4. Ahimsa (non- violence) in contemporary world

62. Which of the following statements regarding the Silk Routes are correct?
 I. They also meant cultural links.
 II. They spread over land and by sea
 III. They connected Asia with Europe and Africa
 IV. Besides textiles gold and silver got exported from Asia to Europe through these routes.
1. I, II and III 2. I, II and IV 3. II, III and IV 4. I, II, III and IV
63. Which of the following statements regarding the impact of Depression of 1929 are correct ?
 I. India's exports increased but imports decreased.
 II. India's export of gold increased.
 III. Urban India suffered more than the rural India.
 IV. Industrial investment grew in India.
1. I, II and III 2. I, III and IV 3. II, III and IV 4. II and IV
64. Which of the following statements about the French in Vietnam are correct ?
 I. The Vietnamese teachers generally twisted the school curriculum given by the French.
 II. The students protested the undue dominance by the colons.
 III. The Annamese Student was a French journal for enlisting the students support.
 IV. The French had to counter the Chinese influence.
1. I, II, and III 2. I, II and IV 3. I, III and IV 4. II, III and IV
65. Read the statements about the impact of forest rules on tribal communities in the 19th century. Which of the following statements are incorrect ?
 I. Jhum cultivators could carry out their activities in village forests.
 II. Jhum cultivators took to plough cultivation with ease.
 III. Tribal people could collect wood and graze cattle in the forests.
 IV. Tribal people had access to protected forests for collecting wood for fuel and house building.
1. I and II 2. I and III 3. II and III 4. III and IV
66. Which of the following statements about the Non-Cooperation Movement are correct ?
 I. The Justice Party participated in the elections in Madras.
 II. The nationalist lawyers did not join back the courts.
 III. The taluqdar were targeted.
 IV. The import of foreign cloth declined and the export of Indian textiles increased manifold.
1. I and II 2. I and IV 3. I, II and III 4. II, III and IV
67. Which of the following regarding the Constitution of 1791 and the status of women in France are correct ?
 I. It made them active citizens.
 II. Provisions were made for schools for both boys and girls.
 III. Divorce rules were made stringent.
 IV. Provisions were made for training women for jobs.
1. I, II, and III 2. III and IV 3. III and IV 4. II, III and IV
68. Arrange the following historical developments in a chronological sequence
 I. Rowlatt Act
 II. Kheda Satyagraha
 III. Champaran Movement
 IV. Ahmedabad Mill Strike
1. I, II, III, IV 2. II, I, III, IV 3. III, I, IV, II 4. III, II, IV, I

Direction (Questions 69-74)

Read the statements and select the correct answer from the options given below.

1. Statement I is true, Statement II is false.
2. Statement I is false, Statement II is true.
3. Both statements are true, and statement II provides explanation to Statement -I
4. Both statements are true, but statement II does not provide explanation of Statement -I

69. **Statement -I** : In the 19th century, London was a colossal city.
Statement -II : London had grown as an industrial city.
70. **Statement -I** : Indians not taking off their turban before colonial officials was considered offending.
Statement -II : Turban was a sign of respectability in India.
71. **Statement -I** : Louis Blanc built a cooperative community.
Statement -II : He believed the community could produce goods together and divide the profits among the members.
72. **Statement -I** : Hand printing developed in China.
Statement -II : The Chinese state printed textbooks in vast numbers.
73. **Statement -I** : Rainfall is low in the western parts of Deccan Plateau and East of Sahyadris.
Statement -II : Western Ghats causes convectional rainfall.
74. **Statement -I** : A large part of Deccan plateau is occupied by black soil.
Statement -II : Black soil in this part was formed by denudation of basaltic rocks overtime.
75. If the local time at Varanasi, located at 83°E longitude is 23 : 00 hour then what will be the local time at Kibithu located at 97°E longitude (Arunachal Pradesh) and Jodhpur, located at 73°E longitude ?
1. 00 : 00 hour, 22 : 00 hour
 2. 22 : 20 hour, 23 : 56 hour
 3. 23 : 56 hour, 22 : 20 hour
 4. 22 : 56 hour, 23 : 20 hour
76. Which one of the following statements are true about latitudes and longitudes
- I. All latitudes are angular distances measured towards the Pole from the Equator
 - II. All longitudes do not join at poles.
 - III. All Parallels and Meridians are imaginary lines.
 - IV. Latitudes are used to determine the time of a place.
1. I and II
 2. I and III
 3. I, II and III
 4. II, III and IV
77. If the current climatic condition of Srinagar (J & K) with average annual temperature of 13.5° C and annual average precipitation 710 mm get modified and become similar to that of Ranchi (Jharkhand) with annual average temperature 23.7°C and precipitation 1430 mm, which one of the following types of vegetation will become predominant in Srinagar ?
1. Tropical Semi Evergreen
 2. Tropical Moist Deciduous
 3. Tropical Dry Deciduous
 4. Tropical Dry Evergreen
78. On a school field trip, a student spotted tigers, turtles, gharials and snakes in their natural habitats. Name the ecological region (delta) where that student had gone.
1. Cauvery
 2. Mahanadi
 3. Godavari
 4. Ganga -Brahmaputra
79. A person travelling by road (shortest distance) from Mangaluru to Machilipatnam will be able to observe natural vegetation types in which of the following sequence ?
1. Montane forest - Tropical Deciduous Forest - Tropical Evergreen Forests
 2. Tropical Evergreen Forests -Tropical Thorn Forests- Tropical Deciduous Forests
 3. Tropical Deciduous Forest - Tropical Evergreen Forests-Mangrove Forests
 4. Tropical Evergreen Forest-Tropical Deciduous Forests - Mangrove Forests

80. Which of the following statement(s) is /are true with respect to monsoons in India ?
- A.** The southwestern Monsoon takes longer duration as compared to retreating Monsoon in covering India.
B. The Southwestern Monsoons has a shorter duration as compared to retreating Monsoon in covering India.
C. Both the Monsoons take almost the same duration in covering India.
D. The Southwestern Monsoon is propelled by the depressions while retreating Monsoons results from the movement of Air Masses.
1. A and D 2. B only 3. C only 4. B and D
81. Which one of the following regions marked on the sketch is an ideal representation with the following characteristics.

- I. The approximate date for arrival for the southwestern monsoon is June 15th
 II. Well developed in Thermal and Nuclear energy production
 III. Rich in the production of oil and natural gas.
 IV. Well developed Textile Industry.

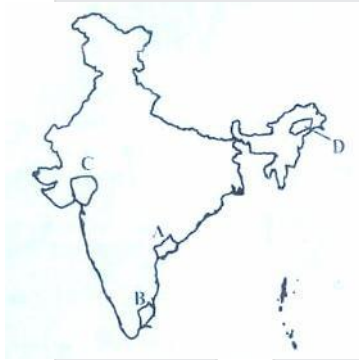

1. A 2. B 3. C 4. D
82. With increasing urbanization, the main activity which leads to loss of bio-diversity is
- I. rural-urban migration.
 II. rapid increase in built-up area.
 III. increased vehicular pollution.
 IV. development of big industrial complexes.
1. I and III 2. I and IV 3. II and IV 4. III and IV

83. Which one of the following statement is NOT Correct about the shaded part on the given outline of India ?



1. It has high potential for hydel-power generation.
 2. It has the lowest degree of urbanization.
 3. Ragi is an important millet grown here.
 4. It is famous for religious tourism.
84. Chandimal, Jaysurya and Umesh left their respective villages in Sri Lanka for Chennai in India. Who among the following could be a refugee?
- I. Chandimal, who is an IT professional, could not find a job in Sri Lanka.
 - II. Jaysurya, who left his village due to ethnic conflicts.
 - III. Umesh, whose land and house were destroyed due to Tsunami.
1. Only Jaysurya
 2. Only Chandimal
 3. Jaysurya and Umesh
 4. Chandimal and Jaysurya
85. Consider the following statements about the United Nations Security Council (UNSC) :
- I. UNSC consists of 15 members.
 - II. US, Russia and Germany are among the permanent members.
 - III. China is the only Asian nation among the permanent members
 - IV. All members of the UNSC have veto power.
- Which of the above statements are correct?
1. I and II
 2. I and III
 3. I and IV
 4. III and IV

86. Which of these statements about the Election Commission of India are true ?
- It conducts and controls the election process in the country.
 - It gets the voters list updated before the elections.
 - It also conducts the Panchayat elections in the country.
 - It approves the election manifestoes of political parties.
1. I and II 2. II and III 3. II and IV 4. III and IV
87. Consider the following statements about the Indian Parliament :
- It is the ultimate authority to make laws in India.
 - It consists of the President, the Lok Sabha and the Rajya Sabha.
 - It consists of only the Lok Sabha and the Rajya Sabha.
 - Lok Sabha members are chosen by the people through elections.
- Which of the above statements are correct?
1. I only 2. I and III 3. II and III 4. I, II and IV
88. Which of the following is the inspiring philosophy of the Constitution of India?
- Secularism, Equality, Communism, Democratic Republic
 - Democratic Republic, Sovereignty, Fraternity
 - Secularism, Equality, Justice
 - Equality, Fraternity, Communalism, Secularism
1. I and II 2. I and III 3. II and III 4. II and IV
89. Which of the following features of the Indian Judiciary are true?
- Integrated Judicial system.
 - The Supreme Court is the highest court of appeal.
 - only the Supreme Court can interpret the Constitution.
 - Public interest litigation (PIL) can be filed only in the Supreme court and the High courts.
1. I, II and III 2. I, II and IV 3. I, II and IV 4. II, III and IV

90. Which of the following statements is NOT true about Indian federalism?
1. The Union government is vested with more financial powers than the state governments.
 2. Power to legislate on residuary subjects is vested in the Union government.
 3. The name and boundaries of a State can be changed by the Union government without the consent of the concerned State.
 4. The Union legislature can amend any provision of the Constitution without the consent of the state governments.
91. Democracy promotes equality through the following :
- I. Universal adult franchise
 - II. Equality before law and equal protection of law.
 - III. Reservation for scheduled Castes, Scheduled Tribes and women
 - IV. Independent and impartial media.
1. I and II 2. I, II and III 3. I, III and IV 4. II and IV
92. Read the following statements and select one of the four options given below.
- Statement I : Enjoyment of pollution –free water is fulfillment of right to life.
- Statement II : Release from forced labour is a fulfillment of right to life.
1. Only I is correct. 2. Only II is correct 3. Both I and II are correct 4. Both I and II are incorrect
93. The daily wage of a person in urban areas is Rs. 300. The poverty line for a person is fixed at Rs. 1000 per month for the urban areas The following table shows the details of employment of four families living in Mumbai city.

Family	Total Days of Employment got in a Month by the family	Members of the family
Hari	12	3
Tenzin	15	4
Bala	15	5
Phulia	20	5

Identify the family living below poverty line.

1. Hari 2. Tenzin 3. Bala 4. Phulia

94. In a particular year, the price of wheat in market is Rs. 15 per kg and a farmer produces 100 kgs of wheat, In the next year the price of wheat has fallen to Rs.10 per kg and the farmer produces 120 kgs. If the government wishes to stabilize the income of the farmer, then what will be the minimum support price ?

1. Rs. 12 per kg 2. Rs 12. 5 per kg 3. Rs. 13 per kg 4. Rs. 13.5 per kg

95. A country has four groups of people. The table below describes some social indicators of these groups. Identify the group that is the most vulnerable.

Groups	Literacy Rate (%)	Life Expectancy (years)	Unemployment rate (%)
A	74	82	5
B	93	80	10
C	63	78	15
D	65	78	10

1. A 2. B 3. C 4. D

96. Which of the following statements are correct?

- I. Bank deposits share the essential features of money.
 II. Any depositor may demand his deposit at any point of time from a bank.
 III. Bank must retain all deposits by itself.

1. I and II are true, but III is false. 2. I is true, but II and III are false.
 3. I and II are false, but III is true. 4. All statements I, II and III are true

97. Bira and his wife Sheena have two daughters aged 12 and 16. Sheena's mother and father, aged 65 and 72, also live with them. Bira is currently looking for work, but can't find any. His elder daughter completed class 10 and prefers to look for work. Sheena prefers to stay at home to look after house works. How many unemployed members does Bira's family have ?

1. 1 2. 2 3. 3 4. 4

98. Which of the following statements are correct?

- I. Globalization has led to increased flow of capital across countries.
 II. Increase in flows of labour across countries has been larger than the increase in flows of capital.
 III. MNCs spread their production and work with local producers in various countries across the globe.

1. I and II 2. I and III 3. II and III 4. I, II and III

99. In a village Puranpur, 200 families are living. Eighty five families work on their own piece of land, 60 families work on the field of other farmers, 5 families run their own shops and 50 families work in a nearby factory to earn their livelihood. What percentage of Puranpur village depends on the secondary sector ?
1. 20 2. 25 3. 35 4. 55
100. Identify the correct pairs from List-I (Rights) and List-II (Violation of rights) and select the correct option using the codes given below.

	List I (Rights)		List-II (Violation of rights)
A	Right to choose	I	Raman buys a packet of milk on which the company's name, manufacturing date, and expiry date were missing.
B	Right to be informed	II	Sakina wants a particular channel from her cable operator but operator offers some other channel as part of a complete package.
C	Right to safety	III	Joseph bought a television from a shop. He suffered electric suffered electric shock while using ti.
D	Right to Seek redressal	IV	Murli fell ill and was admitted in the hospital because of stale food served in the restaurant

1. A-I and C-III

2. B-II and C-III

3. B-II and D-IV

4. C-III and D-IV



रेजोनॅस के विद्यार्थी ने जेईई-मेन (JEE-MAIN)
में लगातार दूसरे वर्ष देश भर में
उच्चतम अंक (350) प्राप्त किये।

AIR 6
PAWAN GOYAL
Reso Roll No.: 13401293
Classroom student since class VIII
350/360

— ★ —
**ALL INDIA RANKS
IN TOP 200**
13 STUDENTS FROM
CLASSROOM PROGRAMS



AIR - 81
SUKHMANJIT S. MANN
Roll No. 16153841



AIR - 97
UDDHARSH KOTAHWALA
Roll No. 15436811



AIR - 108
AYUSH SRIVASTAV
Roll No. 16108129



AIR - 110
SHASHANK ROY
Roll No. 16140446



AIR - 128
PRAKHAR NEEMA
Roll No. 16108146



AIR - 137
P. NITISH
Roll No. 16172084



AIR - 143
HARSH PATEL
Roll No. 13415035



AIR - 184
LAVISH GUPTA
Roll No. 13400690



AIR - 186
RISHABH GUPTA
Roll No. 15402071



AIR - 190
RAHUL ATUL JAIN
Roll No. 14401178



AIR - 191
YASH SANJEEV
Roll No. 16153892



AIR - 197
ARPIT AGARWAL
Roll No. 12403093



AIR - 2 (ST)
JATINI MEENA
Roll No. 17107811

Result at Resonance

Total Students Qualified for JEE (Advanced)

12614

Classroom: 9425 | DLP+ELP: 3189

Total Students selected in JEE (Main)

22557

Classroom: 17751 | DLP+ELP: 4806

ResoNET Dates

27th MAY & 10th JUN 2018

Test Timings: 9 AM to 12 Noon

ADMISSIONS OPEN FOR 2018-19

Classes: V to XII & XII+

Target: JEE (Main+Advanced) | JEE (Main) | AIIMS/ NEET | Pre-foundation | Commerce & CLAT

Resonance Eduventures Limited

Registered & Corporate Office: CG Tower, A-46 & 52, IPIA, Near City Mall, Jhalawar Road, Kota (Rajasthan) - 324005

Tel. No.: 0744-6607777, 6635555 | CIN: U80302RJ2007PLC024029

To know more: sms RESO at 56677 | website: www.resonance.ac.in | e-mail: contact@resonance.ac.in

facebook.com/ResonanceEdu | twitter.com/ResonanceEdu | www.youtube.com/resowatch | blog.resonance.ac.in

Toll Free

1800 258 5555