

CODE

2

PAPER-2

P2-14-2

2219242

Time : 3 Hours

Maximum Marks : 180

Please read the instructions carefully. You are allotted 5 minutes specifically for this purpose.

## INSTRUCTIONS

## A. General

1. This booklet is your Question Paper. Do not break the seal of this booklet before being instructed to do so by the invigilators.
2. The question paper CODE is printed on the left hand top corner of this sheet and on the back cover page of this booklet.
3. Blank spaces and blank pages are provided in the question paper for your rough work. No additional sheets will be provided for rough work.
4. Blank papers, clipboards, log tables, slide rules, calculators, cameras, cellular phones, pagers and electronic gadget of any kind are NOT allowed inside the examination hall.
5. Write your Name and Roll number in the space provided on the back cover of this booklet.
6. Answers to the questions and personal details are to be filled on an Optical Response Sheet, which is provided separately. The ORS is a doublet of two sheets - upper and lower, having identical layout. The upper sheet is a machine-gradable Objective Response Sheet (ORS) which will be collected by the invigilator at the end of the examination. The upper sheet is designed in such a way that darkening the bubble with a ball point pen will leave an identical impression at the corresponding place on the lower sheet. You will be allowed to take away the bottom sheet at the end of the examination, (see Figure -1 on the back cover page for the correct way of darkening the bubbles for valid answers).
7. Use a black ball point pen only to darken the bubbles on the upper original sheet. Apply sufficient pressure so that the impression is created on the lower sheet. See Figure -1 on the back cover page for appropriate way of darkening the bubbles for valid answers.
8. DO NOT TAMPER WITH/MUTILATE THE ORS OR THIS BOOKLET.
9. On breaking the seal of the booklet check that it contains 28 pages and all the 60 questions and corresponding answer choices are legible. Read carefully the instruction printed at the beginning of each section.

## B. Filling the right part of the ORS

10. The ORS also has a CODE printed on its left and right parts.
11. Verify that the CODE printed on the ORS (on both the left and right parts) is the same as that on this booklet and put your signature in the Box designated as R4.
12. IF THE CODES DO NOT MATCH, ASK FOR A CHANGE OF THE BOOKLET / ORS AS APPLICABLE.
13. Write your Name, Roll No. and the name of centre and sign with pen in the boxes provided on the upper sheet of ORS. Do not write any of this anywhere else. Darken the appropriate bubble UNDER each digit of your Roll No. in such way that the impression is created on the bottom sheet. (see example in Figure 2 on the back cover)

## C. Question Paper Format

- The question paper consists of three parts (Physics, Chemistry and Mathematics). Each part consists of three sections.
14. Section 1 contains 10 multiple choice questions. Each question has four choices (A), (B), (C) and (D) out of which ONE is correct.
  15. Section 2 contains 3 paragraphs each describing theory, experiment and data etc. Six questions relate to three paragraphs with two questions on each paragraph. Each question pertaining to a particular passage should have only one correct answer among the four given choices (A), (B), (C) and (D).
  16. Section 3 contains 4 multiple choice questions. Each question has two lists (List-1: P, Q, R and S; List-2 : 1, 2, 3 and 4). The options for the correct match are provided as (A), (B), (C) and (D) out of which ONLY ONE is correct.



Please read the last page of this booklet for rest of the instructions.

DO NOT BREAK THE SEAL WITHOUT BEING INSTRUCTED TO DO SO BY THE INVIGILATOR

	Subject	Section		Page No.
Part I	Physics	1	Only one option correct type	3 - 5
		2	Comprehension Type - Only one option correct	6 - 8
		3	Matching List - Only one option correct	9 - 11
Part II	Chemistry	1	Only one option correct type	12 - 13
		2	Comprehension Type - Only one option correct	14 - 16
		3	Matching List - Only one option correct	17 - 19
Part III	Mathematics	1	Only one option correct type	20 - 21
		2	Comprehension Type - Only one option correct	22 - 23
		3	Matching List - Only one option correct	24 - 26

**Space for Rough Work**

MS  
338  
360  
3x6

100 gm x 9m = F  
100 y 3x10<sup>3</sup> x 6x10<sup>5</sup> = F



# PART I : PHYSICS

## SECTION – 1 : (Only One Option Correct Type)

This section contains 10 multiple choice questions. Each question has four choices (A), (B), (C) and (D) out of which ONLY ONE option is correct.

1. A glass capillary tube is of the shape of a truncated cone with an apex angle  $\alpha$  so that its two ends have cross sections of different radii. When dipped in water vertically, water rises in it to a height  $h$ , where the radius of its cross section is  $b$ . If the surface tension of water is  $S$ , its density is  $\rho$ , and its contact angle with glass is  $\theta$ , the value of  $h$  will be ( $g$  is the acceleration due to gravity)

- (A)  $\frac{2S}{b\rho g} \cos(\theta - \alpha)$   
 (B)  $\frac{2S}{b\rho g} \cos(\theta + \alpha)$   
 (C)  $\frac{2S}{b\rho g} \cos(\theta - \alpha/2)$   
 (D)  $\frac{2S}{b\rho g} \cos(\theta + \alpha/2)$

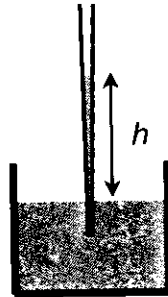

Handwritten notes and calculations:

- $\frac{GM}{R^3}$
- $\frac{GM}{R^2} \times \frac{g}{10} = F$
- $\frac{GM}{R^2} \times \frac{g}{10} = F$
- $\frac{gR}{10}$
- $\frac{R-A}{10}$
- $\frac{R}{10} + \frac{R}{10}$

2. A planet of radius  $R = \frac{1}{10} \times$  (radius of Earth) has the same mass density as Earth. Scientists dig a well of depth  $\frac{R}{5}$  on it and lower a wire of the same length and of linear mass density  $10^{-3} \text{ kg m}^{-1}$  into it. If the wire is not touching anywhere, the force applied at the top of the wire by a person holding it in place is (take the radius of Earth =  $6 \times 10^6 \text{ m}$  and the acceleration due to gravity on Earth is  $10 \text{ ms}^{-2}$ )
- (A) 96 N      (B) 108 N      (C) 120 N      (D) 150 N

3. Charges  $Q$ ,  $2Q$  and  $4Q$  are uniformly distributed in three dielectric solid spheres 1, 2 and 3 of radii  $R/2$ ,  $R$  and  $2R$  respectively, as shown in figure. If magnitudes of the electric fields at point P at a distance  $R$  from the centre of spheres 1, 2 and 3 are  $E_1$ ,  $E_2$  and  $E_3$  respectively, then

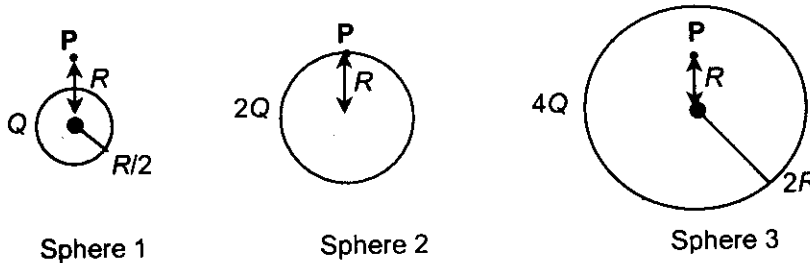

- (A)  $E_1 > E_2 > E_3$       (B)  $E_3 > E_1 > E_2$       (C)  $E_2 > E_1 > E_3$       (D)  $E_3 > E_2 > E_1$

Space for Rough Work

\*\*2

$$E_1 = \frac{kQ}{R^2}$$

$$E_2 = \frac{k(2Q)}{R^2}$$

$$E_3 = \frac{k(4Q)}{2^2 R^2}$$

(2 > 1 > 3)



4. If  $\lambda_{Cu}$  is the wavelength of  $K_{\alpha}$  X-ray line of copper (atomic number 29) and  $\lambda_{Mo}$  is the wavelength of the  $K_{\alpha}$  X-ray line of molybdenum (atomic number 42), then the ratio  $\lambda_{Cu}/\lambda_{Mo}$  is close to  
 (A) 1.99 (B) 2.14 (C) 0.50 (D) 0.48

5. A wire, which passes through the hole in a small bead, is bent in the form of quarter of a circle. The wire is fixed vertically on ground as shown in the figure. The bead is released from near the top of the wire and it slides along the wire without friction. As the bead moves from A to B, the force it applies on the wire is

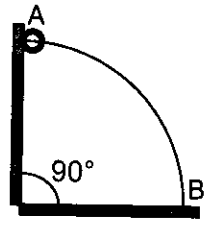

- (A) always radially outwards.  
 (B) always radially inwards.  
 (C) radially outwards initially and radially inwards later.  
 (D) radially inwards initially and radially outwards later.

6. A metal surface is illuminated by light of two different wavelengths 248 nm and 310 nm. The maximum speeds of the photoelectrons corresponding to these wavelengths are  $u_1$  and  $u_2$ , respectively. If the ratio  $u_1:u_2 = 2:1$  and  $hc = 1240 \text{ eV nm}$ , the work function of the metal is nearly  
 (A) 3.7 eV (B) 3.2 eV (C) 2.8 eV (D) 2.5 eV

7. A tennis ball is dropped on a horizontal smooth surface. It bounces back to its original position after hitting the surface. The force on the ball during the collision is proportional to the length of compression of the ball. Which one of the following sketches describes the variation of its kinetic energy  $K$  with time  $t$  most appropriately? The figures are only illustrative and not to the scale.

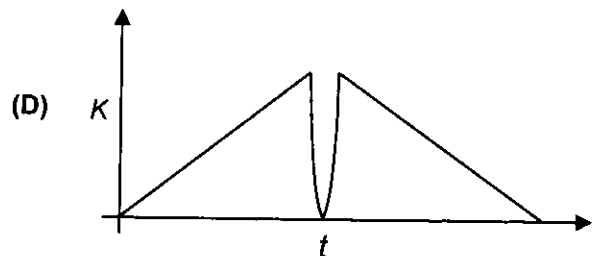
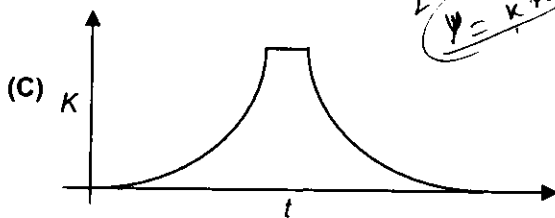
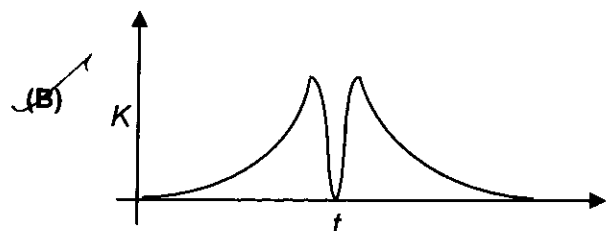
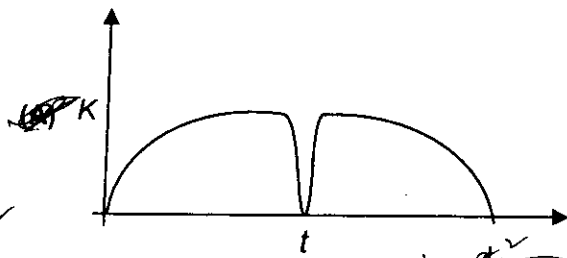

Space for Rough Work

$K = \frac{1}{2} m v^2$

$\kappa = \frac{1}{2} m v^2$   
 $\psi = \kappa n$

\*\* 2

$\kappa_1 : \kappa_2 = 4 : 1$   
 $\kappa_1 = \frac{1240 \cdot 5}{248} - \phi$   
 $\kappa_2 = \frac{1240 \cdot 4}{310} - \phi$   
 $u = \frac{5 - \phi}{4 - \phi}$   
 $16 - 4\phi = 5 - \phi$   
 $11 = 3\phi$



8. During an experiment with a metre bridge, the galvanometer shows a null point when the jockey is pressed at 40.0 cm using a standard resistance of  $90\ \Omega$ , as shown in the figure. The least count of the scale used in the metre bridge is 1 mm. The unknown resistance is

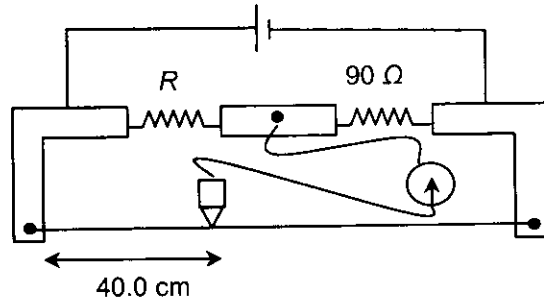

$R \times 90 = \kappa(100 - x)$   
 $60 \times 90 = \kappa + 60 \phi$   
 $60 \times 90 = (100 - x) 60$   
 $90 \Delta L = 100 \Delta R - \Delta R L$   
 $96 \times 1 = 100 \times 6 - 40 \times 60$   
 $15 / 60$

- (A)  $60 \pm 0.15\ \Omega$       (B)  $135 \pm 0.56\ \Omega$       (C)  $60 \pm 0.25\ \Omega$       (D)  $135 \pm 0.23\ \Omega$

9. Parallel rays of light of intensity  $I = 912\ \text{Wm}^{-2}$  are incident on a spherical black body kept in surroundings of temperature 300 K. Take Stefan-Boltzmann constant  $\sigma = 5.7 \times 10^{-8}\ \text{Wm}^{-2}\text{K}^{-4}$  and assume that the energy exchange with the surroundings is only through radiation. The final steady state temperature of the black body is close to

- (A) 330 K      (B) 660 K      (C) 990 K      (D) 1550 K

10. A point source S is placed at the bottom of a transparent block of height 10 mm and refractive index 2.72. It is immersed in a lower refractive index liquid as shown in the figure. It is found that the light emerging from the block to the liquid forms a circular bright spot of diameter 11.54 mm on the top of the block. The refractive index of the liquid is

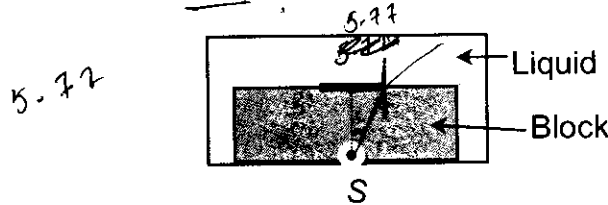

$n_c = \frac{n}{2.72}$   
 $\tan C = \frac{5.77}{10}$   
 $n_c = 0.577$

- (A) 1.21      (B) 1.30      (C) 1.36      (D) 1.42

Space for Rough Work

$n_c = \frac{n}{2.72}$   
 $\tan C = \frac{5.77}{10} \Rightarrow 0.577$   
 $C = 30^\circ$   
 $P = 912\ \text{W} = \sigma A(T^4 - T_0^4)$   
 $912 = 5.7 \times 10^{-8} \times 4\pi r^2 (T^4 - 300^4)$   
 $13400 \times 5 = 304 \times 10^8 + 8 \times 10^8 = T^4$   
 $67 \times 10^8 + 8 \times 10^8 = T^4$   
 $75 \times 10^8 = T^4$   
 $T = 241 \times 10^2$   
 $T = 2410000 \times 10^4$   
 $T = (241)^{1/4} \times 100$



**SECTION – 2 : Comprehension Type (Only One Option Correct)**

This section contains 3 paragraphs, each describing theory, experiments, data etc. Six questions relate to the three paragraphs with two questions on each paragraph. Each question has only one correct answer among the four given options (A), (B), (C) and (D).

**Paragraph For Questions 11 & 12**

The figure shows a circular loop of radius  $a$  with two long parallel wires (numbered 1 and 2) all in the plane of the paper. The distance of each wire from the centre of the loop is  $d$ . The loop and the wires are carrying the same current  $I$ . The current in the loop is in the counterclockwise direction if seen from above.

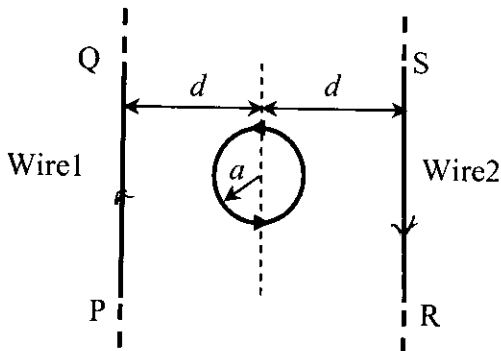

$\frac{\mu_0 I R^2}{2(R^2 + h^2)^{3/2}} = 2B \cos \theta$   
 $\tan \theta = \frac{h}{a}$   
 $\frac{\mu_0 I R^2}{2(R^2 + h^2)^{3/2}} = \frac{\mu_0 I}{2\pi r} \cos \theta$

11. When  $d \approx a$  but wires are not touching the loop, it is found that the net magnetic field on the axis of the loop is zero at a height  $h$  above the loop. In that case
- (A) current in wire 1 and wire 2 is the direction PQ and RS, respectively and  $h \approx a$
  - (B) current in wire 1 and wire 2 is the direction PQ and SR, respectively and  $h \approx a$
  - (C) current in wire 1 and wire 2 is the direction PQ and SR, respectively and  $h \approx 1.2a$
  - (D) current in wire 1 and wire 2 is the direction PQ and RS, respectively and  $h \approx 1.2a$
12. Consider  $d \gg a$ , and the loop is rotated about its diameter parallel to the wires by  $30^\circ$  from the position shown in the figure. If the currents in the wires are in the opposite directions, the torque on the loop at its new position will be (assume that the net field due to the wires is constant over the loop)

- (A)  $\frac{\mu_0 I^2 a^2}{d}$       (B)  $\frac{\mu_0 I^2 a^2}{2d}$       (C)  $\frac{\sqrt{3} \mu_0 I^2 a^2}{d}$       (D)  $\frac{\sqrt{3} \mu_0 I^2 a^2}{2d}$

Space for Rough Work

$\frac{\mu_0 I^2 a^2}{d}$   
 $\vec{\tau} = \vec{m} \times \vec{B}$   
 $B = \frac{\mu_0 I}{2d}$   
 $\frac{a^2}{2(a^2 + h^2)^{3/2}} = \frac{1}{2\pi r}$   
 $\frac{a^2 \pi^2}{a^2 + h^2} = a(a^2 + h^2)$   
 $\frac{a^2 \pi^2}{a^2 + h^2} = a^2 + h^2$   
 $\frac{16a^2}{\pi^2} = h^2$



Paragraph For Questions 13 & 14

In the figure a container is shown to have a movable (without friction) piston on top. The container and the piston are all made of perfectly insulating material allowing no heat transfer between outside and inside the container. The container is divided into two compartments by a rigid partition made of a thermally conducting material that allows slow transfer of heat. The lower compartment of the container is filled with 2 moles of an ideal monatomic gas at 700 K and the upper compartment is filled with 2 moles of an ideal diatomic gas at 400 K. The heat capacities per mole of an ideal monatomic gas are  $C_V = \frac{3}{2}R$ ,  $C_P = \frac{5}{2}R$ , and those for an ideal diatomic gas are  $C_V = \frac{5}{2}R$ ,  $C_P = \frac{7}{2}R$ .

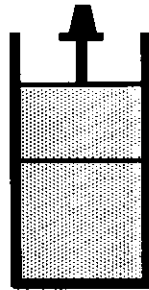

Handwritten calculations for question 13:

400K diatomic  $\frac{5}{2}(700-T) = \frac{5}{2}(T-400)$   
 $2100 - 3T = 5T - 2000$   
 $4100 = 8T$   
 $T = 512.5$

700K monatomic  $\frac{3}{2}(700-T) = \frac{3}{2}(T-400)$   
 $3500 - 3T = 3T - 1200$   
 $4700 = 6T$   
 $T = 783.3$

Final temperature  $T = 512.5$  K

13. Consider the partition to be rigidly fixed so that it does not move. When equilibrium is achieved, the final temperature of the gases will be  
 (A) 550 K (B) 525 K (C) 513 K (D) 490 K
14. Now consider the partition to be free to move without friction so that the pressure of gases in both compartments is the same. Then total work done by the gases till the time they achieve equilibrium will be  
 (A) 250 R (B) 200 R (C) 100 R (D) -100 R

Space for Rough Work

Handwritten equations for question 14:

$T_1 V_1^{\gamma-1} = T_2 V_2^{\gamma-1}$   
 $P_2 V_2 = P_1 V_1$   
 $P_1 V_1^{\gamma} = P_2 V_2^{\gamma}$   
 $n C_V \Delta T$







## SECTION – 3 : Matching List Type (Only One Option Correct)

This section contains four questions, each having two matching lists. Choices for the correct combination of elements from List-I and List-II are given as options (A), (B), (C) and (D), out of which one is correct.

17. A person in a lift is holding a water jar, which has a small hole at the lower end of its side. When the lift is at rest, the water jet coming out of the hole hits the floor of the lift at a distance  $d$  of 1.2 m from the person. In the following, state of the lift's motion is given in List I and the distance where the water jet hits the floor of the lift is given in List II. Match the statements from List I with those in List II and select the correct answer using the code given below the lists.

List I	List II
P. Lift is accelerating vertically up.	1. $d = 1.2\text{ m}$
Q. Lift is accelerating vertically down with an acceleration less than the gravitational acceleration.	2. $d > 1.2\text{ m}$
R. Lift is moving vertically up with constant speed.	3. $d < 1.2\text{ m}$
S. Lift is falling freely.	4. No water leaks out of the jar

Code :

- (A) P-2, Q-3, R-2, S-4  
 (B) P-2, Q-3, R-1, S-4  
 (C) P-1, Q-1, R-1, S-4 ✓  
 (D) P-2, Q-3, R-1, S-1

Space for Rough Work



18. Four charges  $Q_1, Q_2, Q_3$  and  $Q_4$  of same magnitude are fixed along the  $x$  axis at  $x = -2a, -a, +a$  and  $+2a$ , respectively. A positive charge  $q$  is placed on the positive  $y$  axis at a distance  $b > 0$ . Four options of the signs of these charges are given in List I. The direction of the forces on the charge  $q$  is given in List II. Match List I with List II and select the correct answer using the code given below the lists.

- | List I                                      | List II |
|---|---------|
| P. $Q_1, Q_2, Q_3, Q_4$ all positive        | 1. $+x$ |
| Q. $Q_1, Q_2$ positive; $Q_3, Q_4$ negative | 2. $-x$ |
| R. $Q_1, Q_4$ positive; $Q_2, Q_3$ negative | 3. $+y$ |
| S. $Q_1, Q_3$ positive; $Q_2, Q_4$ negative | 4. $-y$ |

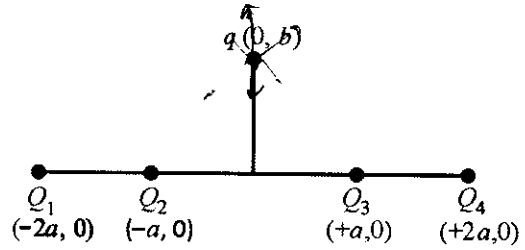

Code :

- (A) ~~P-3, Q-1, R-4, S-2~~  
 (C) P-3, Q-1, R-2, S-4

- (B) P-4, Q-2, R-3, S-1 ✓  
 (D) P-4, Q-2, R-1, S-3 ✗

19. Four combinations of two thin lenses are given in List I. The radius of curvature of all curved surfaces is  $r$  and the refractive index of all the lenses is 1.5. Match lens combinations in List I with their focal length in List II and select the correct answer using the code given below the lists.

- | List I | List II  |
|--------|----------|
| P.     | 1. $2r$  |
| Q.     | 2. $r/2$ |
| R.     | 3. $-r$  |
| S.     | 4. $r$   |

$f = \frac{1}{\frac{1}{a} + \frac{1}{b}}$   
 $\frac{1}{f} = \frac{1}{a} + \frac{1}{b}$

$\frac{1}{f} = \frac{1}{2} \left( \frac{1}{R} + \frac{1}{R} \right)$   
 $\frac{1}{f} = \frac{1}{R}$   
 $\frac{1}{f} = \left( \frac{1}{2} \right) \left( \frac{1}{R} \right)$   
 $\frac{1}{f} = \frac{1}{2R}$

Code :

- (A) P-1, Q-2, R-3, S-4 ✗  
 (C) P-4, Q-1, R-2, S-3 ✗

- (B) P-2, Q-4, R-3, S-1 ✓  
 (D) P-2, Q-1, R-3, S-4 ✗

Space for Rough Work



20. A block of mass  $m_1 = 1 \text{ kg}$  another mass  $m_2 = 2 \text{ kg}$ , are placed together (see figure) on an inclined plane with angle of inclination  $\theta$ . Various values of  $\theta$  are given in List I. The coefficient of friction between the block  $m_1$  and the plane is always zero. The coefficient of static and dynamic friction between the block  $m_2$  and the plane are equal to  $\mu = 0.3$ . In List II expressions for the friction on block  $m_2$  are given. Match the correct expression of the friction in List II with the angles given in List I, and choose the correct option. The acceleration due to gravity is denoted by  $g$ .

[Useful information :  $\tan(5.5^\circ) \approx 0.1$ ;  $\tan(11.5^\circ) \approx 0.2$ ;  $\tan(16.5^\circ) \approx 0.3$ ]

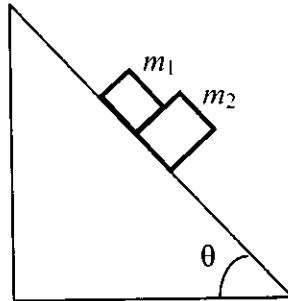

Handwritten notes and calculations:

- $N = m_1 g \sin \theta$
- $\mu m_2 g \cos \theta =$
- $\mu m_2 g \cos \theta = (m_1 + m_2) g \sin \theta$
- $2 \times 0.3 \leq 3 \times \tan \theta$
- $\tan \theta \geq 0.2$
- $\theta \geq 11.5^\circ$

- List I**
- P.  $\theta = 5^\circ$
  - Q.  $\theta = 10^\circ$
  - R.  $\theta = 15^\circ$
  - S.  $\theta = 20^\circ$

- List II**
- 1.  $m_2 g \sin \theta$
  - 2.  $(m_1 + m_2) g \sin \theta$
  - 3.  $\mu m_2 g \cos \theta$
  - 4.  $\mu(m_1 + m_2) g \cos \theta$

Code :

- (A) P-1, Q-1, R-1, S-3
- (B) P-2, Q-2, R-2, S-3
- (C) P-2, Q-2, R-2, S-4
- (D) P-2, Q-2, R-3, S-3

Space for Rough Work



# PART II : CHEMISTRY

## SECTION – 1 : (Only One Option Correct Type)

This section contains 10 multiple choice questions. Each question has four choices (A), (B), (C) and (D) out of which ONLY ONE option is correct.

21. Assuming  $2s-2p$  mixing is **NOT** operative, the paramagnetic species among the following is  
 (A)  $\text{Be}_2$  (B)  $\text{B}_2$  (C)  $\text{C}_2$  (D)  $\text{N}_2$

22. For the process

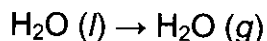

at  $T = 100^\circ\text{C}$  and 1 atmosphere pressure, the correct choice is

- (A)  $\Delta S_{\text{system}} > 0$  and  $\Delta S_{\text{surroundings}} > 0$  (B)  $\Delta S_{\text{system}} > 0$  and  $\Delta S_{\text{surroundings}} < 0$   
 (C)  $\Delta S_{\text{system}} < 0$  and  $\Delta S_{\text{surroundings}} > 0$  (D)  $\Delta S_{\text{system}} < 0$  and  $\Delta S_{\text{surroundings}} < 0$

23. For the elementary reaction  $\text{M} \rightarrow \text{N}$ , the rate of disappearance of **M** increases by a factor of 8 upon doubling the concentration of **M**. The order of the reaction with respect to **M** is

- (A) 4 (B) 3 (C) 2 (D) 1

24. For the identification of  $\beta$ -naphthol using dye test, it is necessary to use

- (A) dichloromethane solution of  $\beta$ -naphthol. (B) acidic solution of  $\beta$ -naphthol.  
 (C) neutral solution of  $\beta$ -naphthol. (D) alkaline solution of  $\beta$ -naphthol.

25. Isomers of hexane, based on their branching, can be divided into three distinct classes as shown in the figure.

[Figure]

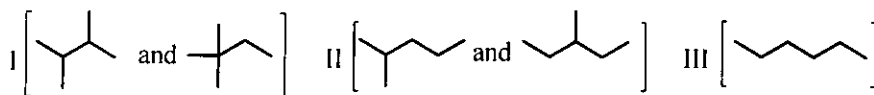

The correct order of their boiling point is

- (A) I > II > III (B) III > II > I (C) II > III > I (D) III > I > II

Space for Rough Work

(3) 36



26. The acidic hydrolysis of ether (X) shown below is fastest when  
[Figure]

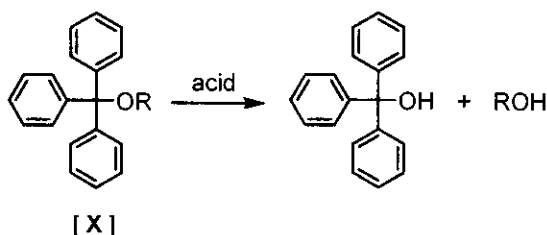

- (A) one phenyl group is replaced by a methyl group.  
 (B) one phenyl group is replaced by a *para*-methoxyphenyl group.  
 (C) two phenyl groups are replaced by two *para*-methoxyphenyl groups.  
 (D) no structural change is made to X.
27. Hydrogen peroxide in its reaction with  $\text{KIO}_4$  and  $\text{NH}_2\text{OH}$  respectively, is acting as a  
 (A) reducing agent, oxidising agent      (B) reducing agent, reducing agent  
 (C) oxidising agent, oxidising agent      (D) oxidising agent, reducing agent
28. The major product in the following reaction is  
[Figure]

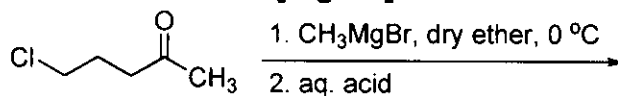

- (A) (B)   
 (C) (D)
29. Under ambient conditions, the total number of gases released as products in the final step of the reaction scheme shown below is

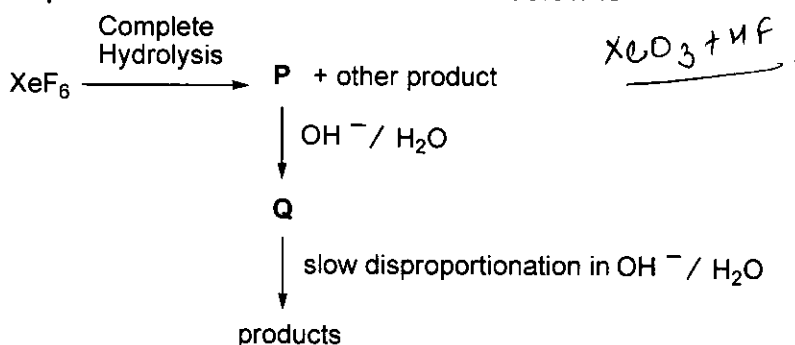

- (A) 0                      (B) 1                      (C) 2                      (D) 3
30. The product formed in the reaction of  $\text{SOCl}_2$  with white phosphorous is  
 (A)  $\text{PCl}_3$               (B)  $\text{SO}_2\text{Cl}_2$               (C)  $\text{SCl}_2$               (D)  $\text{POCl}_3$

Space for Rough Work



**SECTION – 2 : Comprehension Type (Only One Option Correct)**

This section contains 3 paragraphs, each describing theory, experiments, data etc. Six questions relate to the three paragraphs with two questions on each paragraph. Each question has only one correct answer among the four given options (A), (B), (C) and (D).

**Paragraph For Questions 31 and 32**

X and Y are two volatile liquids with molar weights of  $10 \text{ g mol}^{-1}$  and  $40 \text{ g mol}^{-1}$  respectively. Two cotton plugs, one soaked in X and the other soaked in Y, are simultaneously placed at the ends of a tube of length  $L = 24 \text{ cm}$ , as shown in the figure. The tube is filled with an inert gas at 1 atmosphere pressure and a temperature of 300 K. Vapours of X and Y react to form a product which is first observed at a distance  $d \text{ cm}$  from the plug soaked in X. Take X and Y to have equal molecular diameters and assume ideal behaviour for the inert gas and the two vapours.

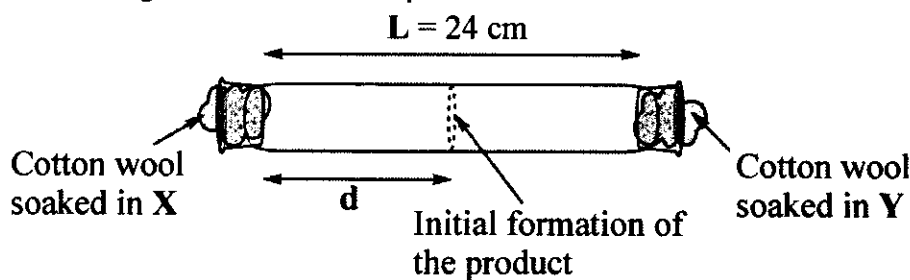

31. The value of  $d$  in cm (shown in the figure), as estimated from Graham's law, is  
 (A) 8                      (B) 12                      (C) 16                      (D) 20
32. The experimental value of  $d$  is found to be smaller than the estimate obtained using Graham's law. This is due to  
 (A) larger mean free path for X as compared to that of Y.  
 (B) larger mean free path for Y as compared to that of X.  
 (C) increased collision frequency of Y with the inert gas as compared to that of X with the inert gas.  
 (D) increased collision frequency of X with the inert gas as compared to that of Y with the inert gas.

Space for Rough Work



Paragraph For Questions 33 and 34

Schemes 1 and 2 describe sequential transformation of alkynes M and N. Consider only the major products formed in each step for both the schemes.

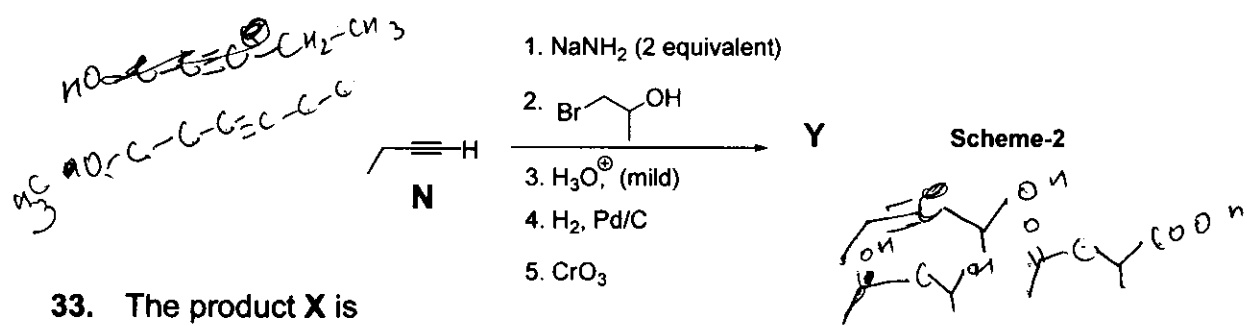
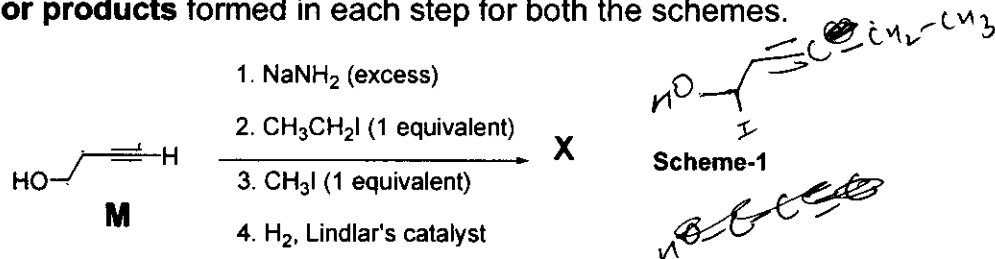

33. The product X is

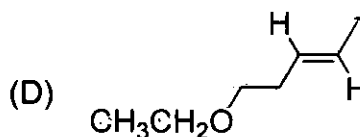
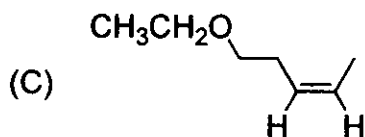
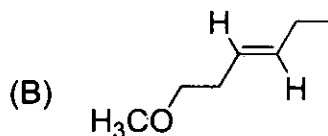
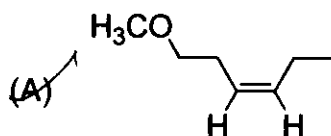

34. The correct statement with respect to product Y is

- (A) It gives a positive Tollens test and is a functional isomer of X.
- (B) It gives a positive Tollens test and is a geometrical isomer of X.
- (C) It gives a positive iodoform test and is a functional isomer of X.
- (D) It gives a positive iodoform test and is a geometrical isomer of X.

Space for Rough Work







**SECTION – 3 : Matching List Type (Only One Option Correct)**

This section contains four questions, each having two matching lists. Choices for the correct combination of elements from List-I and List-II are given as options (A), (B), (C) and (D), out of which one is correct.

37. Match each coordination compound in List-I with an appropriate pair of characteristics from List-II and select the correct answer using the code given below the lists.

{en = H<sub>2</sub>NCH<sub>2</sub>CH<sub>2</sub>NH<sub>2</sub>; atomic numbers: Ti = 22; Cr = 24; Co = 27; Pt = 78}



- | List-I   | List-II   |
|--|---|
| P. [Cr(NH <sub>3</sub> ) <sub>4</sub> Cl <sub>2</sub> ]Cl                              | 1. Paramagnetic and exhibits ionisation isomerism       |
| Q. [Ti(H <sub>2</sub> O) <sub>5</sub> Cl](NO <sub>3</sub> ) <sub>2</sub>               | 2. Diamagnetic and exhibits <i>cis-trans</i> isomerism  |
| R. [Pt(en)(NH <sub>3</sub> )Cl]NO <sub>3</sub>   | 3. Paramagnetic and exhibits <i>cis-trans</i> isomerism |
| S. [Co(NH <sub>3</sub> ) <sub>4</sub> (NO <sub>3</sub> ) <sub>2</sub> ]NO <sub>3</sub> | 4. Diamagnetic and exhibits ionisation isomerism        |

Code :

	P	Q	R	S
(A)	4	2	3	1
(B)	3	1	4	2
(C)	2	1	3	4
(D)	1	3	4	2

*Handwritten notes:*  
 n-3=0  
 3d<sup>5</sup> 4s<sup>1</sup>  
 3d<sup>3</sup>  
 3d<sup>1</sup>  
 sc Ti<sup>3+</sup> vs Cr<sup>3+</sup> etc  
 a u b 2  
 (aa) b b  
 n-3=0  
 (f) (g) (h)

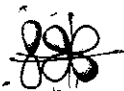
38. Match the orbital overlap figures shown in List-I with the description given in List-II and select the correct answer using the code given below the lists.

- | List-I   | List-II                |
|--|------------------------|
| P.  | 1. p – d π antibonding |
| Q.  | 2. d – d σ bonding     |
| R.  | 3. p – d π bonding     |
| S.  | 4. d – d σ antibonding |

Code :

	P	Q	R	S
(A)	2	1	3	4
(B)	4	3	1	2
(C)	2	3	1	4
(D)	4	1	3	2

Space for Rough Work



39. Different possible **thermal** decomposition pathways for peroxyesters are shown below. Match each pathway from **List I** with an appropriate structure from **List II** and select the correct answer using the code given below the lists.

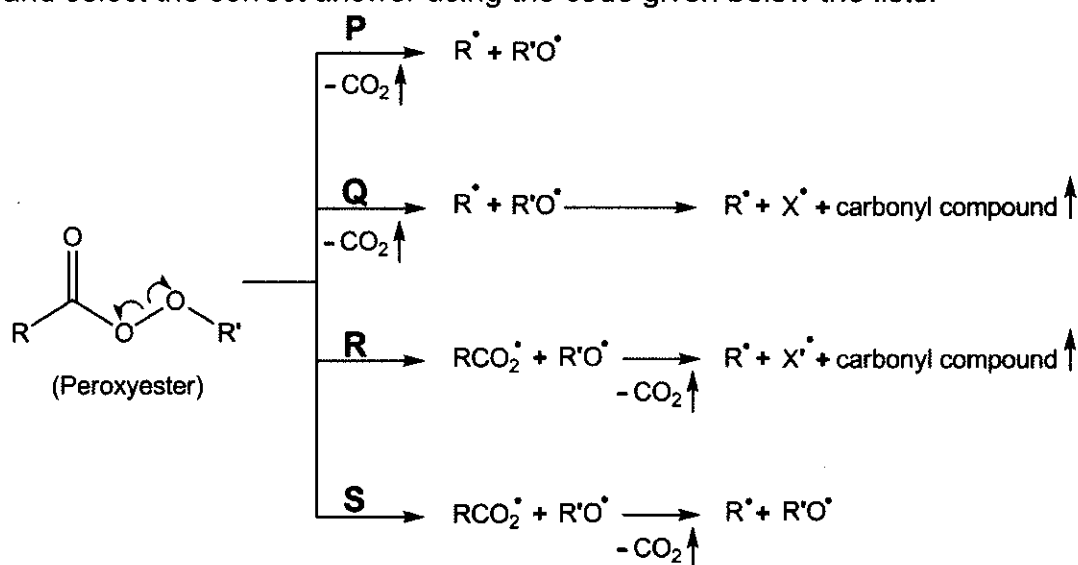

**List-I**

- P. Pathway P
- Q. Pathway Q
- R. Pathway R
- S. Pathway S

**List-II**

1. Cc1ccc(cc1)CC(=O)OOC
2. Cc1ccc(cc1)C(=O)OOC
3. Cc1ccc(cc1)CC(=O)OOC(C)(C)Cc2ccccc2
4. Cc1ccc(cc1)C(=O)OOC(C)(C)c2ccccc2

**Codes :**

	P	Q	R	S
(A)	1	3	4	2
(B)	2	4	3	1
(C)	4	1	2	3
(D)	3	2	1	4

Space for Rough Work



40. Match the four starting materials (P, Q, R, S) given in List I with the corresponding reaction schemes (I, II, III, IV) provided in List II and select the correct answer using the code given below the lists.

List-I

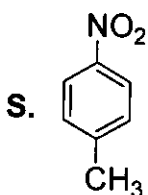
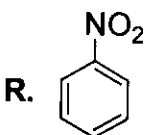
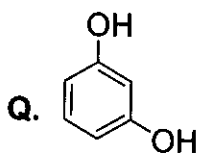
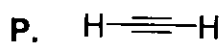

List-II

1. Scheme I

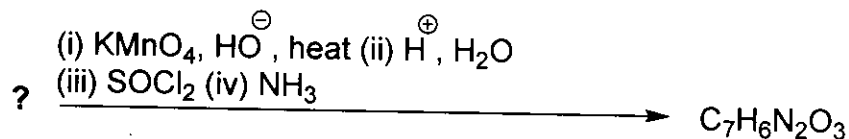

2. Scheme II

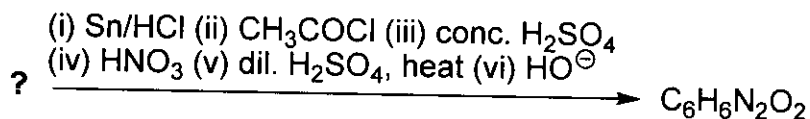

3. Scheme III

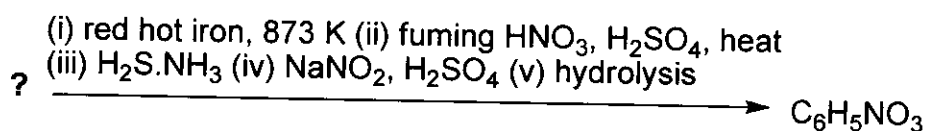

4. Scheme IV

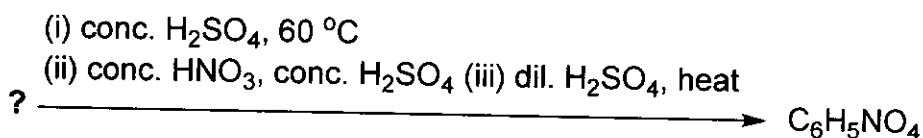

Code :

	P	Q	R	S
(A)	1	4	2	3 ✓
(B)	3	1	4	2
(C)	3	4	2	1 ✓
(D)	4	1	3	2

Space for Rough Work

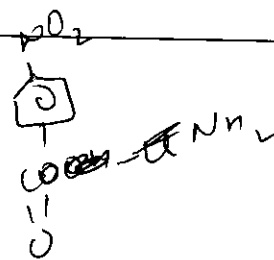
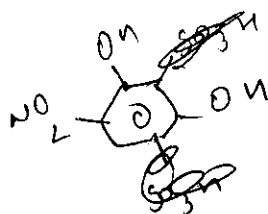

# PART III : MATHEMATICS

## SECTION – 1 : (Only One Option Correct Type)

This section contains 10 multiple choice questions. Each question has four choices (A), (B), (C) and (D) out of which **ONLY ONE** option is correct.

41. The quadratic equation  $p(x) = 0$  with real coefficients has purely imaginary roots. Then the equation

$$p(p(x)) = 0$$

has

- (A) only purely imaginary roots
- (B) all real roots
- (C) two real and two purely imaginary roots
- (D) neither real nor purely imaginary roots

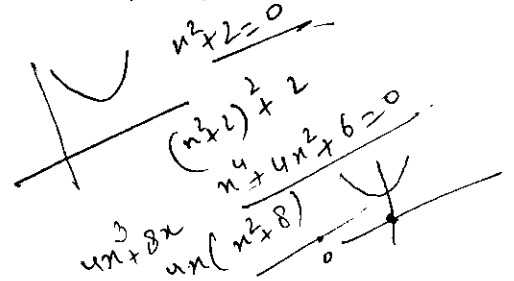

42. Three boys and two girls stand in a queue. The probability, that the number of boys ahead of every girl is at least one more than the number of girls ahead of her, is

- (A)  $\frac{1}{2}$
- (B)  $\frac{1}{3}$
- (C)  $\frac{2}{3}$
- (D)  $\frac{3}{4}$

43. Six cards and six envelopes are numbered 1, 2, 3, 4, 5, 6 and cards are to be placed in envelopes so that each envelope contains exactly one card and no card is placed in the envelope bearing the same number and moreover the card numbered 1 is always placed in envelope numbered 2. Then the number of ways it can be done is

- (A) 264
- (B) 265
- (C) 53
- (D) 67

44. In a triangle the sum of two sides is  $x$  and the product of the same two sides is  $y$ . If  $x^2 - c^2 = y$ , where  $c$  is the third side of the triangle, then the ratio of the in-radius to the circum-radius of the triangle is

- (A)  $\frac{3y}{2x(x+c)}$
- (B)  $\frac{3y}{2c(x+c)}$
- (C)  $\frac{3y}{4x(x+c)}$
- (D)  $\frac{3y}{4c(x+c)}$

45. The common tangents to the circle  $x^2 + y^2 = 2$  and the parabola  $y^2 = 8x$  touch the circle at the points  $P, Q$  and the parabola at the points  $R, S$ . Then the area of the quadrilateral  $PQRS$  is

- (A) 3
- (B) 6
- (C) 9
- (D) 15

Space for Rough Work

Handwritten rough work for question 45:

- Circle:  $x^2 + y^2 = 2$ , radius =  $\sqrt{2}$ , center =  $(0,0)$
- Parabola:  $y^2 = 8x$ , focus =  $(2,0)$
- Common tangents:  $ax + by + c = 0$
- Condition for tangency to circle:  $a^2 + b^2 = 2c^2$
- Condition for tangency to parabola:  $c = 2a$
- Solving these gives  $a = \pm 2, b = \pm 2, c = \pm 4$
- Tangents:  $2x + 2y + 4 = 0$  and  $2x - 2y + 4 = 0$
- Points of tangency on circle:  $(-1, -1)$  and  $(-1, 1)$
- Points of tangency on parabola:  $(-2, 2)$  and  $(-2, -2)$
- Area of quadrilateral PQRS =  $\frac{1}{2} \times \text{diagonal}_1 \times \text{diagonal}_2$
- Diagonal 1:  $\sqrt{(-1+2)^2 + (-1-2)^2} = \sqrt{10}$
- Diagonal 2:  $\sqrt{(-1-2)^2 + (-1+2)^2} = \sqrt{10}$
- Area =  $\frac{1}{2} \times \sqrt{10} \times \sqrt{10} = 5$



46. The function  $y = f(x)$  is the solution of the differential equation

$$\frac{dy}{dx} + \frac{xy}{x^2 - 1} = \frac{x^4 + 2x}{\sqrt{1 - x^2}}$$

in  $(-1, 1)$  satisfying  $f(0) = 0$ . Then

$$\int_{-\frac{\sqrt{3}}{2}}^{\frac{\sqrt{3}}{2}} f(x) dx$$

is

- (A)  $\frac{\pi}{3} - \frac{\sqrt{3}}{2}$       (B)  $\frac{\pi}{3} - \frac{\sqrt{3}}{4}$       (C)  $\frac{\pi}{6} - \frac{\sqrt{3}}{4}$       (D)  $\frac{\pi}{6} - \frac{\sqrt{3}}{2}$

47. Let  $f: [0, 2] \rightarrow \mathbb{R}$  be a function which is continuous on  $[0, 2]$  and is differentiable on  $(0, 2)$  with  $f(0) = 1$ . Let

$$F(x) = \int_0^{x^2} f(\sqrt{t}) dt$$

for  $x \in [0, 2]$ . If  $F'(x) = f'(x)$  for all  $x \in (0, 2)$ , then  $F(2)$  equals

- (A)  $e^2 - 1$       (B)  $e^4 - 1$       (C)  $e - 1$       (D)  $e^4$

48. Coefficient of  $x^{11}$  in the expansion of  $(1 + x^2)^4 (1 + x^3)^7 (1 + x^4)^{12}$  is

- (A) 1051      (B) 1106      (C) 1113      (D) 1120

49. For  $x \in (0, \pi)$ , the equation  $\sin x + 2 \sin 2x - \sin 3x = 3$  has

- (A) infinitely many solutions      (B) three solutions  
(C) one solution      (D) no solution

50. The following integral

$$\int_{\frac{\pi}{4}}^{\frac{\pi}{2}} (2 \operatorname{cosec} x)^{17} dx$$

- (A)  $\int_0^{\log(1+\sqrt{2})} 2(e^u + e^{-u})^{16} du$       (B)  $\int_0^{\log(1+\sqrt{2})} (e^u + e^{-u})^{17} du$   
(C)  $\int_0^{\log(1+\sqrt{2})} (e^u - e^{-u})^{17} du$       (D)  $\int_0^{\log(1+\sqrt{2})} 2(e^u - e^{-u})^{16} du$

Space for Rough Work

Handwritten rough work including binomial coefficients, integrals, and calculations:

- $\int \tan^x x = \frac{\tan^x x}{x} - \int \frac{\tan^{x-2} x}{x} dx$
- $\int \sec^x x = \frac{\sec^x x}{x} - \int \frac{\sec^{x-2} x}{x} dx$
- Binomial coefficients:  ${}^n C_0, {}^n C_1, \dots, {}^n C_n$
- Calculus:  $\frac{d}{dx} \tan^{-1} x = \frac{1}{1+x^2}$ ,  $\frac{d}{dx} \cot^{-1} x = \frac{-1}{1+x^2}$
- Integration:  $\int \frac{1}{x^2+1} dx = \tan^{-1} x + C$
- Algebra:  $\frac{7 \times 6 \times 5}{6} = 35$ ,  $\frac{7 \times 6 \times 5 \times 4}{24} = 35$



SECTION – 2 : Comprehension Type (Only One Option Correct)

This section contains 3 paragraphs, each describing theory, experiments, data etc. Six questions relate to the three paragraphs with two questions on each paragraph. Each question has only one correct answer among the four given options (A), (B), (C) and (D).

Paragraph For Questions 51 and 52

Box 1 contains three cards bearing numbers 1, 2, 3; box 2 contains five cards bearing numbers 1, 2, 3, 4, 5; and box 3 contains seven cards bearing numbers 1, 2, 3, 4, 5, 6, 7. A card is drawn from each of the boxes. Let  $x_i$  be the number on the card drawn from the  $i^{th}$  box,  $i = 1, 2, 3$ .

51. The probability that  $x_1 + x_2 + x_3$  is odd, is  
 (A)  $\frac{29}{105}$       (B)  $\frac{53}{105}$       (C)  $\frac{57}{105}$       (D)  $\frac{1}{2}$
52. The probability that  $x_1, x_2, x_3$  are in an arithmetic progression, is  
 (A)  $\frac{9}{105}$       (B)  $\frac{10}{105}$       (C)  $\frac{11}{105}$       (D)  $\frac{7}{105}$

Space for Rough Work

(3, 3)

Handwritten rough work for questions 51 and 52:

- For Q51: "both odd both even", "6+7", "7+4", "13", "even", "x1+x3", "3, 7, 3", "3 odd", "2 odd 1 odd", "2/3", "2/3 + 2/3 = 4/3", "2/3 + 2/3 = 4/3", "2x2x3", "2x2x3", "2x4 + 1x3 = 11", "2x4 + 1x3 = 11", "105", "24 + 8 + 9 + 12 = 53", "24 + 29 = 53".
- For Q52: "3 odd", "2 even 1 odd", "5x4", "7x6x5", "3x2x5x3x7x4", "3x10x35", "105, 0", "2x3x4 = 24", "24 + 2x4 + 1x3x3 + 2x2x3 = 53", "24 + 8 + 9 + 12 = 53", "24 + 29 = 53".



$$\frac{a}{t^2} - \frac{2a}{t} \quad a \left( \frac{-1}{t} \right)$$

**Paragraph For Questions 53 and 54**

Let  $a, r, s, t$  be nonzero real numbers. Let  $P(at^2, 2at)$ ,  $Q$ ,  $R(ar^2, 2ar)$  and  $S(as^2, 2as)$  be distinct points on the parabola  $y^2 = 4ax$ . Suppose that  $PQ$  is the focal chord and lines  $QR$  and  $PK$  are parallel, where  $K$  is the point  $(2a, 0)$ .

53. The value of  $r$  is

- (A)  $-\frac{1}{t}$       (B)  $\frac{t^2+1}{t}$       (C)  $\frac{1}{t}$       (D)  $\frac{t^2-1}{t}$

54. If  $st = 1$ , then the tangent at  $P$  and the normal at  $S$  to the parabola meet at a point whose ordinate is

- (A)  $\frac{(t^2+1)^2}{2t^3}$       (B)  $\frac{a(t^2+1)^2}{2t^3}$       (C)  $\frac{a(t^2+1)^2}{t^3}$       (D)  $\frac{a(t^2+2)^2}{t^3}$

$ty = x + at^2$   
 $5x + y = 2as + at^3$   
 $b(ty - at^2) + y = 2as + as^3$   
 $y - at + y = 2as + as^3$   
 $2y = 2as + as^3 + at$

**Paragraph For Questions 55 and 56**

Given that for each  $a \in (0, 1)$ ,

$$\lim_{h \rightarrow 0^+} \int_h^{1-h} t^{-a}(1-t)^{a-1} dt$$

exists. Let this limit be  $g(a)$ . In addition, it is given that the function  $g(a)$  is differentiable on  $(0, 1)$ .

55. The value of  $g\left(\frac{1}{2}\right)$  is

- (A)  $\pi$       (B)  $2\pi$       (C)  $\frac{\pi}{2}$       (D)  $\frac{\pi}{4}$

56. The value of  $g'\left(\frac{1}{2}\right)$  is

- (A)  $\frac{\pi}{2}$       (B)  $\pi$       (C)  $-\frac{\pi}{2}$       (D)  $0$

Space for Rough Work

Handwritten work for the limit problem:

$$\int_0^1 t^{-a} (1-t)^{a-1} dt = \frac{(1-t)^a}{-a} - (-at^{-a-1})$$

$$\int_0^1 (1-t)^{-a} (t)^{a-1} dt = \frac{(1-t)^{-a+1}}{-a+1} + \frac{t^a}{a}$$

$$\int_0^1 (1-t)^{a-1} (t)^{-a} dt = \frac{(1-t)^a}{a} + \frac{t^{-a+1}}{-a+1}$$

Using the property  $\int_0^1 f(x) dx = \int_0^1 f(1-x) dx$ :

$$\int_0^1 t^{-a} (1-t)^{a-1} dt = \int_0^1 (1-t)^{-a} (t)^{a-1} dt$$

$$\int_0^1 (1-t)^{a-1} (t)^{-a} dt = \int_0^1 (1-t)^{a-1} (t)^{a-1} dt = \int_0^1 (1-t)^{2a-2} dt$$

$$= \frac{(1-t)^{2a-1}}{2a-1} \Big|_0^1 = \frac{1 - 1^{2a-1}}{2a-1} = \frac{1}{2a-1}$$

Therefore,  $g(a) = \frac{1}{2a-1}$

For  $a = \frac{1}{2}$ ,  $g\left(\frac{1}{2}\right) = \frac{1}{2 \cdot \frac{1}{2} - 1} = \frac{1}{1-1}$  (undefined)

For  $a = \frac{1}{2}$ ,  $g'(a) = \frac{d}{da} \left( \frac{1}{2a-1} \right) = -\frac{1}{(2a-1)^2}$

At  $a = \frac{1}{2}$ ,  $g'\left(\frac{1}{2}\right) = -\frac{1}{(2 \cdot \frac{1}{2} - 1)^2} = -\frac{1}{0^2}$  (undefined)

Wait, let's re-evaluate the integral result. The integral  $\int_0^1 t^{-a} (1-t)^{a-1} dt$  is a Beta function  $B(a, a) = \frac{\Gamma(a)\Gamma(a)}{\Gamma(2a)}$ .

For  $a = \frac{1}{2}$ ,  $B\left(\frac{1}{2}, \frac{1}{2}\right) = \frac{\Gamma\left(\frac{1}{2}\right)\Gamma\left(\frac{1}{2}\right)}{\Gamma(1)} = \frac{\sqrt{\pi} \cdot \sqrt{\pi}}{1} = \pi$

Therefore,  $g\left(\frac{1}{2}\right) = \pi$ .

For  $a = \frac{1}{2}$ ,  $g'(a) = \frac{d}{da} \left( \frac{\Gamma(a)\Gamma(a)}{\Gamma(2a)} \right)$

Using  $\frac{d}{dx} \Gamma(x) = \Gamma(x)\psi(x)$ , where  $\psi(x)$  is the digamma function.

At  $a = \frac{1}{2}$ ,  $\psi\left(\frac{1}{2}\right) = -\gamma - 2\ln 2$ , where  $\gamma$  is the Euler-Mascheroni constant.

Therefore,  $g'\left(\frac{1}{2}\right) = \frac{\Gamma\left(\frac{1}{2}\right)\Gamma\left(\frac{1}{2}\right)}{\Gamma(1)} (\psi\left(\frac{1}{2}\right) + \psi\left(\frac{1}{2}\right) - 2\psi(1)) = \pi (-2\gamma - 4\ln 2 - 2) = -2\pi(\gamma + 2\ln 2 + 1)$

None of the options match this. Let's check the options again: (A)  $\frac{\pi}{2}$ , (B)  $\pi$ , (C)  $-\frac{\pi}{2}$ , (D)  $0$ .

Wait, the question asks for  $g'\left(\frac{1}{2}\right)$ . The options are (A)  $\frac{\pi}{2}$ , (B)  $\pi$ , (C)  $-\frac{\pi}{2}$ , (D)  $0$ .

Let's re-calculate  $g(a)$  using the Beta function property  $B(x, y) = \int_0^1 t^{x-1} (1-t)^{y-1} dt = \frac{\Gamma(x)\Gamma(y)}{\Gamma(x+y)}$ .

Here,  $x = 1-a$  and  $y = a$ . So  $g(a) = \frac{\Gamma(1-a)\Gamma(a)}{\Gamma(1)} = \Gamma(1-a)\Gamma(a)$ .

Using the reflection formula  $\Gamma(x)\Gamma(1-x) = \frac{\pi}{\sin(\pi x)}$ .

Therefore,  $g(a) = \frac{\pi}{\sin(\pi a)}$ .

For  $a = \frac{1}{2}$ ,  $g\left(\frac{1}{2}\right) = \frac{\pi}{\sin\left(\frac{\pi}{2}\right)} = \frac{\pi}{1} = \pi$ .

For  $a = \frac{1}{2}$ ,  $g'(a) = \frac{d}{da} \left( \frac{\pi}{\sin(\pi a)} \right) = \frac{\pi \cos(\pi a)}{\sin^2(\pi a)}$ .

At  $a = \frac{1}{2}$ ,  $g'\left(\frac{1}{2}\right) = \frac{\pi \cos\left(\frac{\pi}{2}\right)}{\sin^2\left(\frac{\pi}{2}\right)} = \frac{\pi \cdot 0}{1^2} = 0$ .

Therefore, the correct answer for 56 is (D)  $0$ .

SECTION - 3 : Matching List Type (Only One Option Correct)

This section contains four questions, each having two matching lists. Choices for the correct combination of elements from List-I and List-II are given as options (A), (B), (C) and (D), out of which one is correct.

57.

List I

List II

P. The number of polynomials  $f(x)$  with non-negative integer coefficients of degree  $\leq 2$ , satisfying  $f(0) = 0$  and  $\int_0^1 f(x) dx = 1$ , is

1. 8

Q. The number of points in the interval  $[-\sqrt{13}, \sqrt{13}]$  at which  $f(x) = \sin(x^2) + \cos(x^2)$  attains its maximum value, is

2. 2

R.  $\int_{-2}^2 \frac{3x^2}{(1+e^x)} dx$  equals

3. 4

S.  $\frac{\int_{-\frac{1}{2}}^{\frac{1}{2}} \cos 2x \log\left(\frac{1+x}{1-x}\right) dx}{\left(\int_0^{\frac{1}{2}} \cos 2x \log\left(\frac{1+x}{1-x}\right) dx\right)}$  equals

4. 0

	P	Q	R	S
(A)	3	2	4	1
(B)	2	3	4	1
(C)	3	2	1	4
(D)	2	3	1	4

*Handwritten notes:*  
 $a_n x^n + b_n x^{n-1} + \dots$   
 $a \frac{n^3}{3} + b \frac{n^2}{2}$   
 $3x^2 + 2x + b$   
 $\frac{a}{3} + \frac{b}{2} = 1$   
 $2a + 3b = 6$   
 $a=0$

58.

List I

List II

P. Let  $y(x) = \cos(3 \cos^{-1} x)$ ,  $x \in [-1, 1]$ ,  $x \neq \pm \frac{\sqrt{3}}{2}$ . Then

1. 1

$\frac{1}{y(x)} \left\{ (x^2 - 1) \frac{d^2 y(x)}{dx^2} + x \frac{dy(x)}{dx} \right\}$  equals

2. 2

Q. Let  $A_1, A_2, \dots, A_n$  ( $n > 2$ ) be the vertices of a regular polygon of  $n$  sides with its centre at the origin. Let  $\vec{a}_k$  be the position vector of the point  $A_k$ ,  $k = 1, 2, \dots, n$ . If  $|\sum_{k=1}^{n-1} (\vec{a}_k \times \vec{a}_{k+1})| = |\sum_{k=1}^{n-1} (\vec{a}_k \cdot \vec{a}_{k+1})|$ , then the minimum value of  $n$  is

3. 8

R. If the normal from the point  $P(h, 1)$  on the ellipse  $\frac{x^2}{6} + \frac{y^2}{3} = 1$  is perpendicular to the line  $x + y = 8$ , then the value of  $h$  is

4. 9

S. Number of positive solutions satisfying the equation

$$\tan^{-1}\left(\frac{1}{2x+1}\right) + \tan^{-1}\left(\frac{1}{4x+1}\right) = \tan^{-1}\left(\frac{2}{x^2}\right)$$

	P	Q	R	S
(A)	4	3	2	1
(B)	2	4	3	1
(C)	4	3	1	2
(D)	2	4	1	3

*Handwritten notes:*  
 $\tan^{-1} \frac{1}{\sqrt{2}}$   
 $\frac{y - \beta \sin \theta}{x - \beta \cos \theta} = \tan \theta$   
 $y - 1 = x - \frac{1}{\sqrt{2}}$   
 $y - \beta \sin \theta = \frac{x - \beta \cos \theta}{\sqrt{2}}$   
 $y = 2n - 1$

Space for Rough Work

*Handwritten notes:*  
 $\frac{2x}{x^2} = 3$   
 $\frac{1}{\sqrt{2}} \cos \theta = \frac{\beta \sin \theta}{\sqrt{2}}$   
 $\frac{n}{\cos \theta} - \frac{y}{\sin \theta} = 3$   
 $\sqrt{2}n - \sqrt{2}y = 3$





59. Let  $f_1: \mathbb{R} \rightarrow \mathbb{R}$ ,  $f_2: [0, \infty) \rightarrow \mathbb{R}$ ,  $f_3: \mathbb{R} \rightarrow \mathbb{R}$  and  $f_4: \mathbb{R} \rightarrow [0, \infty)$  be defined by

$$f_1(x) = \begin{cases} |x| & \text{if } x < 0, \\ e^x & \text{if } x \geq 0; \end{cases}$$

$$f_2(x) = x^2;$$

$$f_3(x) = \begin{cases} \sin x & \text{if } x < 0, \\ x & \text{if } x \geq 0 \end{cases}$$

and

$$f_4(x) = \begin{cases} f_2(f_1(x)) & \text{if } x < 0, \\ f_2(f_1(x)) - 1 & \text{if } x \geq 0. \end{cases}$$

List I

- P.  $f_4$  is
- Q.  $f_3$  is
- R.  $f_2 \circ f_1$  is
- S.  $f_2$  is

List II

- 1. onto but not one-one
- 2. neither continuous nor one-one
- 3. differentiable but not one-one
- 4. continuous and one-one

	P	Q	R	S
(A)	3	1	4	2 ✓
(B)	1	3	4	2 ✓
(C)	3	1	2	4 ✓ ✓
(D)	1	3	2	4 ✓ ✓

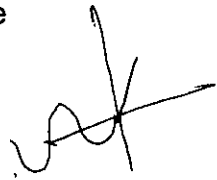

Space for Rough Work

$$y \sqrt{n^2-1} = \int \frac{n^4 + 2n \sqrt{n^2-1} \, dn}{\sqrt{1-n^2}}$$

$$IF = \sqrt{n^2-1}$$

$$y \sqrt{n^2-1} = \int \frac{n^4 + 2n \sqrt{n^2-1} \, dn}{\sqrt{1-n^2}}$$

$$\ln(n + \sqrt{n^2-1}) \Big|_{-\beta/2}^{\beta/2}$$

$$\ln\left(\frac{\sqrt{3}}{2}\right)$$

$$IF = \frac{1}{2} \int \frac{2n \, dn}{n^2-1}$$

$$e^{\frac{1}{2} \ln(n^2-1)}$$

$$e^{\ln \sqrt{n^2-1}}$$

$$y = \frac{n^2 + \frac{n^5}{5}}{\sqrt{n^2-1}} \Big|_{-\beta/2}^{\beta/2} + \int_{-\beta/2}^{\beta/2} \frac{n^2 \, dn}{\sqrt{n^2-1}}$$

$$y \sqrt{n^2-1} = \frac{n^5}{5} + n^2$$

\*\* 2

$$\int_{-\beta/2}^{\beta/2} \frac{1}{\sqrt{n^2-1}} + \sqrt{n^2-1}$$





**Space for Rough Work**

© 2000 Pearson Education, Inc.



**D. Marking Scheme**

17. For each question in **Section 1, 2 and 3** you will be awarded **3 marks** if you darken the bubble corresponding to the correct answer and **zero mark** if no bubble is darkened. In all other cases, **minus one (-1) mark** will be awarded.

Appropriate way of darkening the bubble for your answer to be evaluated :











		→	The one and the only acceptable	Answer will not be evaluated - no marks, no negative marks
		→	Part darkening	
		→	Darkening the rim	
		→	Cancelling after darkening	
		→	Erasing after darkening	

Figure-1 : Correct way of bubbling for valid answer and a few examples of invalid answers. Any other form of partial marking such as ticking or crossing the bubble will be invalid.

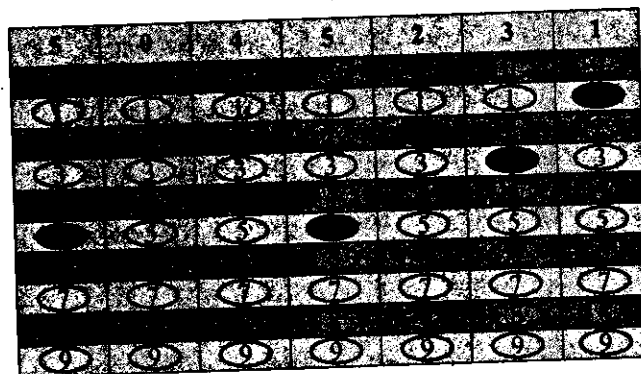
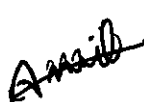
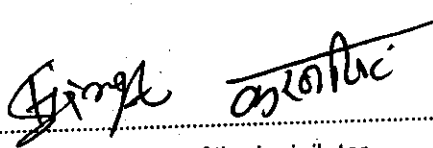

Figure-2 : Correct Way of Bubbling your Roll Number on the ORS. (Example Roll Number : 5045231)

<b>Name of the Candidate</b>	<b>Roll Number</b>							
AHIT SHARMA	<table border="1" style="margin: auto; border-collapse: collapse;"> <tr> <td style="padding: 2px 10px;">2</td> <td style="padding: 2px 10px;">0</td> <td style="padding: 2px 10px;">4</td> <td style="padding: 2px 10px;">5</td> <td style="padding: 2px 10px;">2</td> <td style="padding: 2px 10px;">3</td> <td style="padding: 2px 10px;">1</td> </tr> </table>	2	0	4	5	2	3	1
2	0	4	5	2	3	1		
I have read all instructions and shall abide by them.	I have verified all the information filled by the candidate.							
 _____ Signature of the Candidate	 _____ Signature of the Invigilator							