

JEE MAIN 2016

ONLINE EXAMINATION

DATE : 10-04-2016

SUBJECT : PHYSICS

TEST PAPER

WITH SOLUTIONS & ANSWER KEY





RESONANCE EDUVENTURES LTD.

CORPORATE OFFICE : CG TOWER, A-46 & 52, IPIA, NEAR CITY MALL, JHALAWAR ROAD, KOTA (RAJ.) - 324005

REG. OFFICE : J-2, JAWAHAR NAGAR, MAIN ROAD, KOTA (RAJ.)-324005 | PH. NO.: +91-744-3192222 | FAX NO. : +91-022-39167222

PH.NO. : +91-744-3012222, 6635555 | TO KNOW MORE : SMS RESO AT 56677

WEBSITE : WWW.RESONANCE.AC.IN | E-MAIL : CONTACT@RESONANCE.AC.IN | CIN : U80302RJ2007PLC024029

Toll Free : 1800 258 5555  08003 444 888  facebook.com/ResonanceEdu  twitter.com/ResonanceEdu  www.youtube.com/resowatch  blog.resonance.ac.in

THIS SOLUTION WAS DOWNLOADED FROM RESONANCE JEE Main 2016 SOLUTION PORTAL

JEE (Advanced)

Selections
(from 2002-2015)

23182

(YCCP: 14864 | DLP+eLP: 8318)

Selections @ 2015

4124

(YCCP: 2570 | DLP+eLP: 1554)

*Highest selections in JEE (Adv) 2015
in India from any single institute of Kota*

JEE (Main)

Selections
(from 2009-2015)

93915

(YCCP: 66288 | DLP+eLP: 27627)

Selections @ 2015

25542

(YCCP: 18816 | DLP+eLP: 6726)

*Highest selections in JEE (Main) 2015
in India from any single institute of Kota*

For Classes: XI, XII & XII+

Target: JEE (Main + Advanced) | JEE (Main) | Board/ IJSO/ NTSE

**Resonance National Entrance Test
(ResoNET)**

8th & 15th May, 2016

Toll Free: 1800 258 5555

1. A bottle has an opening of radius a and length b . A cork of length b and radius $(a + \Delta a)$ where $(\Delta a \ll a)$ is compressed to fit into the opening completely (See figure). If the bulk modulus of cork is B and frictional coefficient between the bottle and cork is μ then the force needed to push the cork into the bottle is :

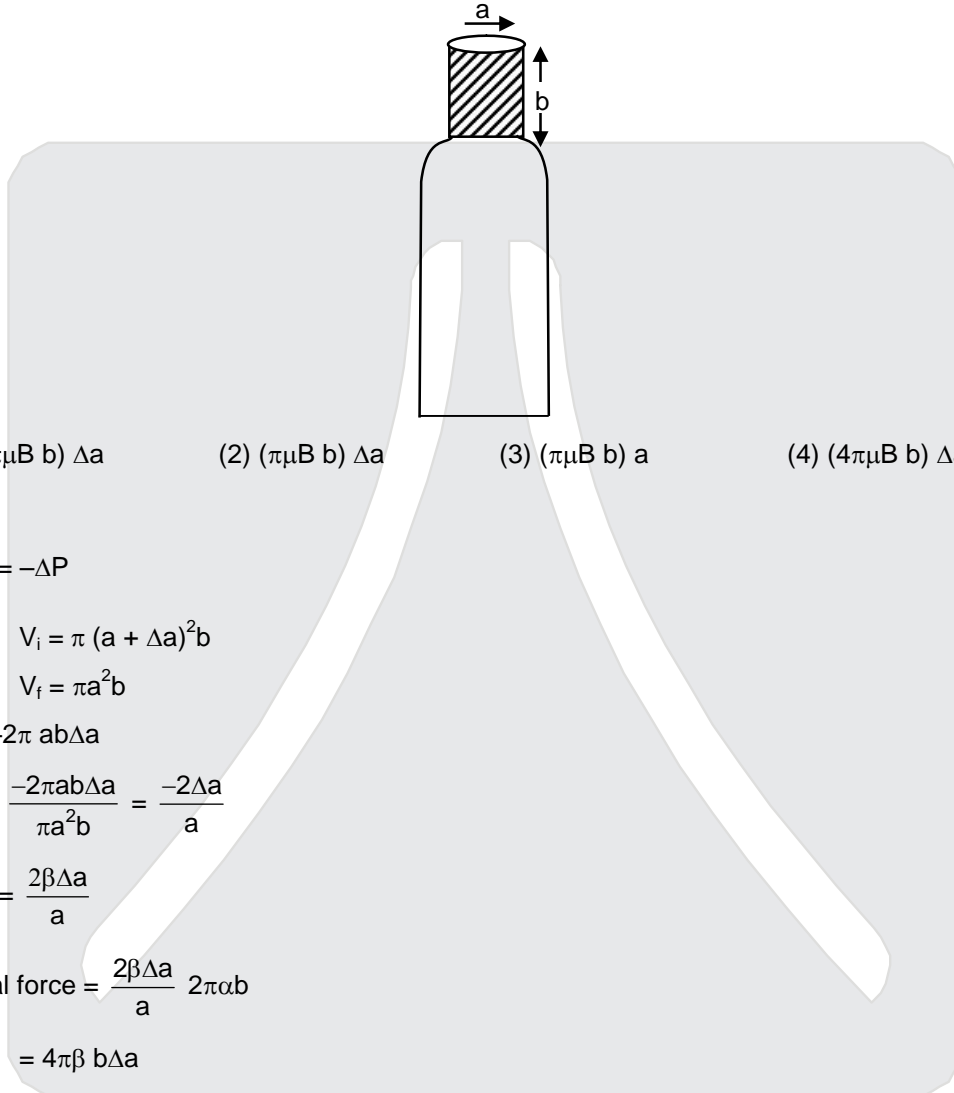

- (1) $(2\pi\mu B b) \Delta a$ (2) $(\pi\mu B b) \Delta a$ (3) $(\pi\mu B b) a$ (4) $(4\pi\mu B b) \Delta a$

Ans. (4)

Sol. $\beta \frac{\Delta V}{V} = -\Delta P$

$$V_i = \pi (a + \Delta a)^2 b$$

$$V_f = \pi a^2 b$$

$$\Delta V \approx -2\pi ab\Delta a$$

$$\frac{\Delta V}{V} = \frac{-2\pi ab\Delta a}{\pi a^2 b} = \frac{-2\Delta a}{a}$$

$$\Rightarrow \Delta P = \frac{2\beta\Delta a}{a}$$

$$\text{Normal force} = \frac{2\beta\Delta a}{a} \cdot 2\pi a b$$

$$= 4\pi\beta b\Delta a$$

$$\text{friction} = \mu N$$

$$= 4\pi\mu\beta b \Delta a$$

RESONANCE EDUVENTURES LTD.

CORPORATE OFFICE : CG TOWER, A-46 & 52, IPIA, NEAR CITY MALL, JHALAWAR ROAD, KOTA (RAJ.) - 324005

REG. OFFICE : J-2, JAWAHAR NAGAR, MAIN ROAD, KOTA (RAJ.)-324005 | PH. NO.: +91-744-3192222 | FAX NO. : +91-022-39167222

PH.NO. : +91-744-3012222, 6635555 | TO KNOW MORE : SMS RESO AT 56677

WEBSITE : WWW.RESONANCE.AC.IN | E-MAIL : CONTACT@RESONANCE.AC.IN | CIN : U80302RJ2007PLC024029

Toll Free : 1800 258 5555 | 08003 444 888 | facebook.com/ResonanceEdu | twitter.com/ResonanceEdu | www.youtube.com/resowatch | blog.resonance.ac.in

2. Consider an electromagnetic wave propagating in vacuum. Choose the correct statement :
- (1) For an electromagnetic wave propagating in +y direction the electric field is $\vec{E} = \frac{1}{\sqrt{2}} E_{yz}(x,t)\hat{z}$ and the magnetic field is $\vec{B} = \frac{1}{\sqrt{2}} B_z(x,t)\hat{y}$
- (2) For an electromagnetic wave propagating in +y direction the electric field is $\vec{E} = \frac{1}{\sqrt{2}} E_{yz}(x,t)\hat{y}$ and the magnetic field is $\vec{B} = \frac{1}{\sqrt{2}} B_{yz}(x,t)\hat{z}$
- (3) For an electromagnetic wave propagating in +x direction the electric field is $\vec{E} = \frac{1}{\sqrt{2}} E_{yz}(y,z,t)(\hat{y} + \hat{z})$ and the magnetic field is $\vec{B} = \frac{1}{\sqrt{2}} B_{yz}(y,z,t)(\hat{y} + \hat{z})$
- (4) For an electromagnetic wave propagating in +x direction the electric field is $\vec{E} = \frac{1}{\sqrt{2}} E_{yz}(x,t)(\hat{y} - \hat{z})$ and the magnetic field is $\vec{B} = \frac{1}{\sqrt{2}} B_{yz}(x,t)(\hat{y} + \hat{z})$

Ans. (4)

Sol. If wave is propagating in x direction, \vec{E} & \vec{B} must be functions of (x, t) & must be in y-z plane.

3. A galvanometer has a 50 division scale. Battery has no internal resistance. It is found that there is deflection of 40 divisions when $R = 2400 \Omega$. Deflection becomes 20 divisions when resistance taken from resistance box is 4900Ω . Then we can conclude :

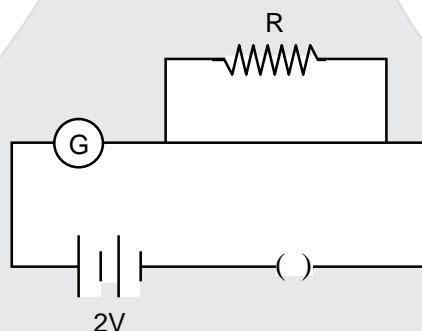

- (1) Resistance required on R.B. For a deflection of 10 divisions is 9800Ω .
- (2) Full scale deflection current is 2 mA.
- (3) Current sensitivity of galvanometer is $20 \mu\text{A}/\text{division}$.
- (4) Resistance of galvanometer is 200Ω .

Ans. Bonus

RESONANCE EDUVENTURES LTD.

CORPORATE OFFICE : CG TOWER, A-46 & 52, IPIA, NEAR CITY MALL, JHALAWAR ROAD, KOTA (RAJ.) - 324005

REG. OFFICE : J-2, JAWAHAR NAGAR, MAIN ROAD, KOTA (RAJ.)-324005 | PH. NO.: +91-744-3192222 | FAX NO. : +91-022-39167222

PH.NO. : +91-744-3012222, 6635555 | TO KNOW MORE : SMS RESO AT 56677

WEBSITE : WWW.RESONANCE.AC.IN | E-MAIL : CONTACT@RESONANCE.AC.IN | CIN : U80302RJ2007PLC024029

Toll Free : 1800 258 5555 | 08003 444 888 | [facebook.com/ResonanceEdu](https://www.facebook.com/ResonanceEdu) | twitter.com/ResonanceEdu | www.youtube.com/resowatch | blog.resonance.ac.in

4. A carnot freezer takes heat from water at 0°C inside it and rejects it to the room at a temperature of 27°C . The latent heat of ice is $336 \times 10^3 \text{ J kg}^{-1}$. If 5 kg of water at 0°C is converted into ice at 0°C by the freezer, then the energy consumed by the freezer is close to :
- (1) $1.68 \times 10^6 \text{ J}$ (2) $1.71 \times 10^7 \text{ J}$ (3) $1.51 \times 10^5 \text{ J}$ (4) $1.67 \times 10^5 \text{ J}$

Ans. (4)

Sol.

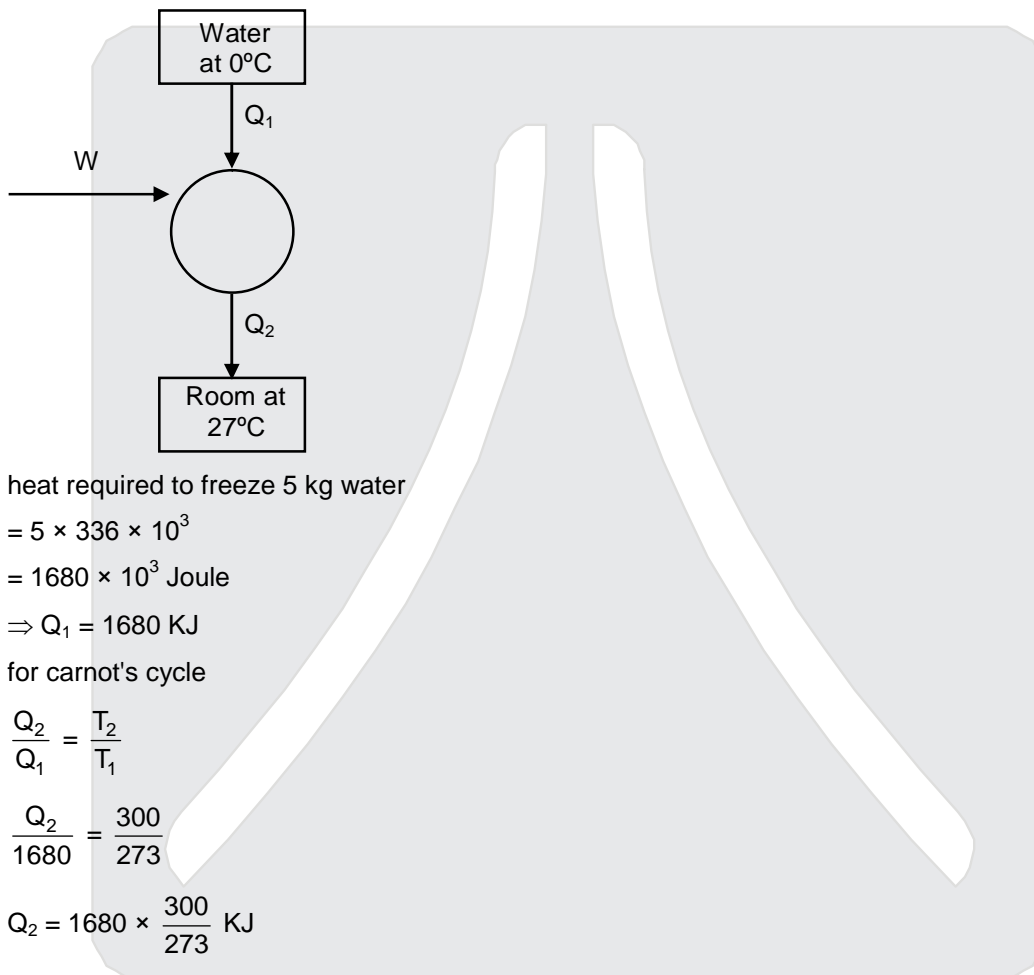

heat required to freeze 5 kg water

$$= 5 \times 336 \times 10^3$$

$$= 1680 \times 10^3 \text{ Joule}$$

$$\Rightarrow Q_1 = 1680 \text{ KJ}$$

for carnot's cycle

$$\frac{Q_2}{Q_1} = \frac{T_2}{T_1}$$

$$\frac{Q_2}{1680} = \frac{300}{273}$$

$$Q_2 = 1680 \times \frac{300}{273} \text{ KJ}$$

$$W = Q_2 - Q_1$$

$$= 1680 \left(\frac{300}{273} - 1 \right)$$

$$= \frac{1680 \times 27}{273} \times 10^3 \text{ J}$$

$$= 166.15 \times 10^3 \text{ J}$$

$$= 1.66 \times 10^5 \text{ KJ}$$





RESONANCE EDUVENTURES LTD.

CORPORATE OFFICE : CG TOWER, A-46 & 52, IPIA, NEAR CITY MALL, JHALAWAR ROAD, KOTA (RAJ.) - 324005

REG. OFFICE : J-2, JAWAHAR NAGAR, MAIN ROAD, KOTA (RAJ.)-324005 | PH. NO.: +91-744-3192222 | FAX NO. : +91-022-39167222

PH.NO. : +91-744-3012222, 6635555 | TO KNOW MORE : SMS RESO AT 56677

WEBSITE : WWW.RESONANCE.AC.IN | E-MAIL : CONTACT@RESONANCE.AC.IN | [CIN : U80302RJ2007PLC024029](http://CIN:U80302RJ2007PLC024029)

Toll Free : 1800 258 5555  08003 444 888  facebook.com/ResonanceEdu  twitter.com/ResonanceEdu  www.youtube.com/resowatch  blog.resonance.ac.in

5. A realistic graph depicting the variation of the reciprocal of input resistance in an input characteristics measurement in a common emitter transistor configuration is :

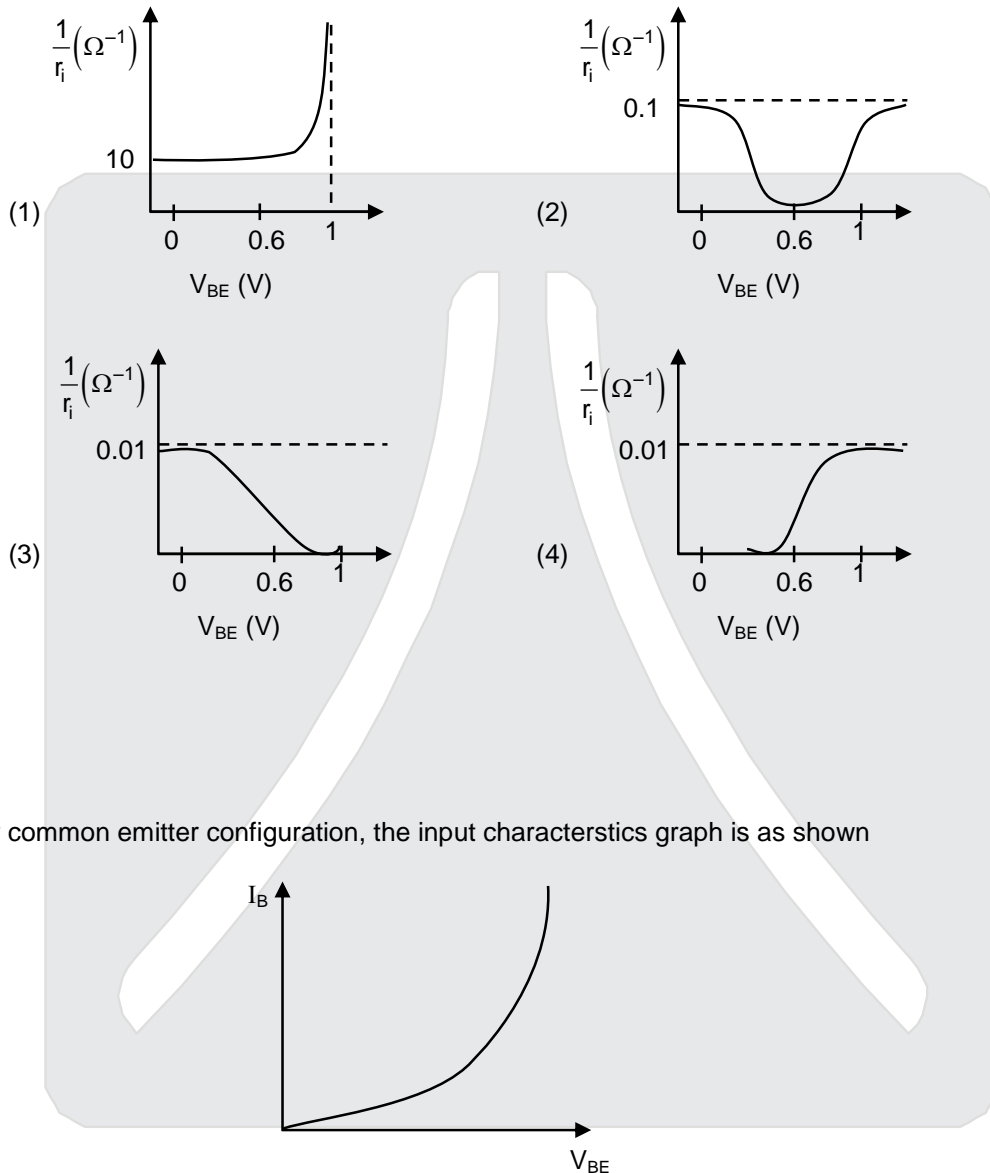

Ans. (1)

Sol. For common emitter configuration, the input characteristics graph is as shown

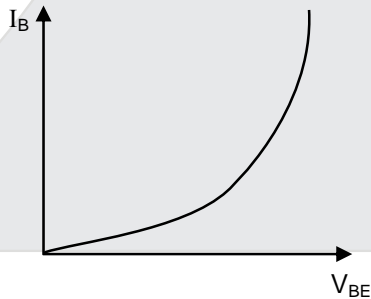

$$r_i = \frac{\Delta V_i}{\Delta I_i} \Rightarrow \frac{1}{r_i} = \frac{dI_i}{dV_i} = \text{slope}$$

RESONANCE EDUVENTURES LTD.

CORPORATE OFFICE : CG TOWER, A-46 & 52, IPIA, NEAR CITY MALL, JHALAWAR ROAD, KOTA (RAJ.) - 324005

REG. OFFICE : J-2, JAWAHAR NAGAR, MAIN ROAD, KOTA (RAJ.)-324005 | PH. NO.: +91-744-3192222 | FAX NO. : +91-022-39167222

PH.NO. : +91-744-3012222, 6635555 | TO KNOW MORE : SMS RESO AT 56677

WEBSITE : WWW.RESONANCE.AC.IN | E-MAIL : CONTACT@RESONANCE.AC.IN | CIN : U80302RJ2007PLC024029

Toll Free : 1800 258 5555 | 08003 444 888 | facebook.com/ResonanceEdu | twitter.com/ResonanceEdu | www.youtube.com/resowatch | blog.resonance.ac.in

6. A particle of mass m is acted upon by a force F given by the empirical law $F = \frac{R}{t^2} v(t)$. If this law is to be tested experimentally by observing the motion starting from rest, the best way is to plot :
- (1) $\log v(t)$ against t (2) $v(t)$ against t^2
 (3) $\log v(t)$ against $\frac{1}{t^2}$ (4) $\log v(t)$ against $\frac{1}{t}$

Ans. (4)

Sol.

$$m \frac{dv}{dt} = \frac{R}{t^2} v$$

$$\Rightarrow m \frac{dv}{v} = R \frac{dt}{t^2}$$

$$\Rightarrow m \int_{v_1}^{v_2} \frac{dv}{v} = R \int_{t_1}^{t_2} \frac{dt}{t^2}$$

$$\Rightarrow m \ln \left(\frac{v_2}{v_1} \right) = \frac{-R}{t} \Big|_{t_1}^{t_2}$$

$$\Rightarrow \ln \left(\frac{v_2}{v_1} \right) = \frac{-R}{m} \left(\frac{1}{t_2} - \frac{1}{t_1} \right)$$

$\log v$ vs $\frac{1}{t}$ will be a st. line curve

7. A fighter plane of length 20m, wing span (distance from tip of one wing to the tip of the other wing) of 15 m and height 5m is flying towards east over Delhi. Its speed is 240 ms^{-1} . The earth's magnetic field over Delhi is $5 \times 10^{-5} \text{ T}$ with the declination angle -0° and dip of θ such that $\sin \theta = \frac{2}{3}$. If the voltage developed is V_B between the lower and upper side of the plane and V_W between the tips the wings then V_B and V_W are closed to :

- (1) $V_B = 40 \text{ mV}$, $V_W = 135 \text{ mV}$ with left side of pilot at higher voltage.
 (2) $V_B = 40 \text{ mV}$, $V_W = 135 \text{ mV}$ with right side of pilot at high voltage.
 (3) $V_B = 45 \text{ mV}$, $V_W = 120 \text{ mV}$ with left side of pilot at higher voltage.
 (4) $V_B = 45 \text{ mV}$, $V_W = 120 \text{ mV}$ with right side of pilot at higher voltage.

Ans. (3)
Sol.

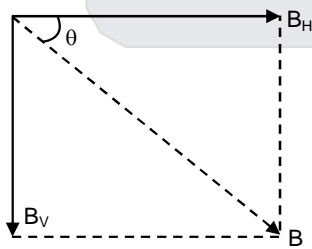

$$V_B = B \sin \theta \quad (5) \quad (240)$$

$$B_H = B \cos \theta$$

$$B_H = \frac{5\sqrt{5} \times 10^{-5}}{3}$$

RESONANCE EDUVENTURES LTD.

CORPORATE OFFICE : CG TOWER, A-46 & 52, IPIA, NEAR CITY MALL, JHALAWAR ROAD, KOTA (RAJ.) - 324005

REG. OFFICE : J-2, JAWAHAR NAGAR, MAIN ROAD, KOTA (RAJ.)-324005 | PH. NO.: +91-744-3192222 | FAX NO. : +91-022-39167222

PH.NO. : +91-744-3012222, 6635555 | TO KNOW MORE : SMS RESO AT 56677

WEBSITE : WWW.RESONANCE.AC.IN | E-MAIL : CONTACT@RESONANCE.AC.IN | CIN : U80302RJ2007PLC024029

Toll Free : 1800 258 5555

08003 444 888

facebook.com/ResonanceEdu

twitter.com/ResonanceEdu

www.youtube.com/resowatch

blog.resonance.ac.in

$$B_V = \frac{10}{3} \times 10^{-5} \text{ T}$$

$$V_B = \frac{5\sqrt{5}}{3} \times 10^{-5} \times 5 \times 240$$

$$V_B = 44.6 \text{ mV} = 45 \text{ mV}$$

$$V_W = B_V \ell V$$

$$= 10^{-4} \times 1200$$

$$V_w = 120 \text{ mV}$$

(left side at fighter voltage)

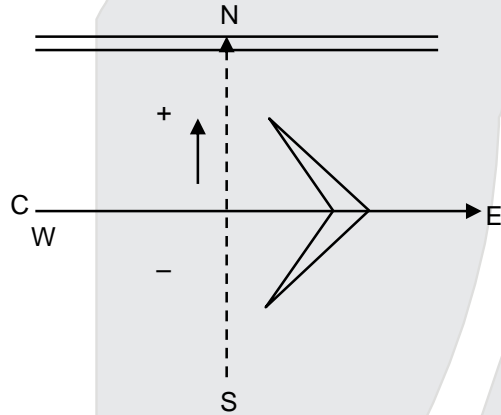

8. To get an output of 1 from the circuit shown in figure the input must be :

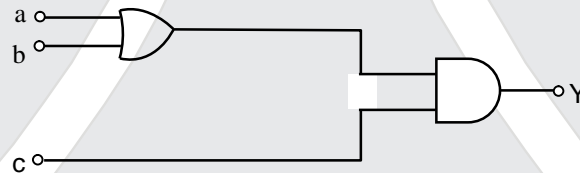

(1) $a=1, b=1, c=0$

(2) $a=1, b=0, c=0$

(3) $a=0, b=0, c=1$

(4) $a=1, b=0, c=1$

Ans. (4)

Sol. Checking options one by one

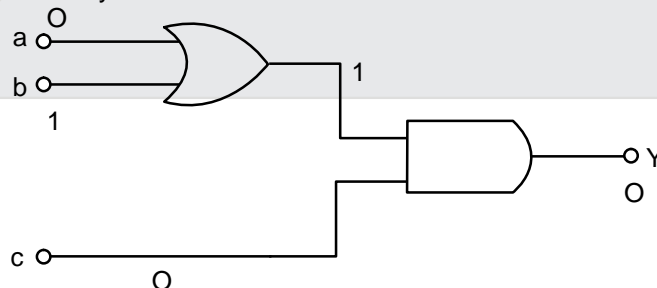

We must note that $c = 1$
and output of OR gate must also be 1
therefore

RESONANCE EDUVENTURES LTD.

CORPORATE OFFICE : CG TOWER, A-46 & 52, IPIA, NEAR CITY MALL, JHALAWAR ROAD, KOTA (RAJ.) - 324005

REG. OFFICE : J-2, JAWAHAR NAGAR, MAIN ROAD, KOTA (RAJ.)-324005 | PH. NO.: +91-744-3192222 | FAX NO. : +91-022-39167222

PH.NO. : +91-744-3012222, 6635555 | TO KNOW MORE : SMS RESO AT 56677

WEBSITE : WWW.RESONANCE.AC.IN | E-MAIL : CONTACT@RESONANCE.AC.IN | CIN : U80302RJ2007PLC024029

Toll Free : 1800 258 5555 | WhatsApp: 08003 444 888 | Facebook: facebook.com/ResonanceEdu | Twitter: twitter.com/ResonanceEdu | YouTube: www.youtube.com/resowatch | Blog: blog.resonance.ac.in

9. To determine refractive index of glass slab using a travelling microscope, minimum number of readings required are :
 (1) Four (2) Two (3) Three (4) Five

Ans. (3)

10. An astronaut of mass m is working on a satellite orbiting the earth at a distance h from the earth's surface. The radius of the earth is R , while its mass is M . The gravitational pull F_G on the astronaut is:

- (1) $F_G = \frac{GM_m}{(R+h)^2}$
 (2) zero since astronaut feels weightless
 (3) $\frac{GM_m}{(R+h)^2} < F_G < \frac{GM_m}{R^2}$
 (4) $0 < F_G < \frac{GM_m}{R^2}$

Ans. (1)

Sol. $F_G = \frac{GMm}{(R+h)^2}$

11. In the figure shown/ ABC is a uniform wire. If centre of mass wire lies vertically below point A, then $\frac{BC}{AB}$

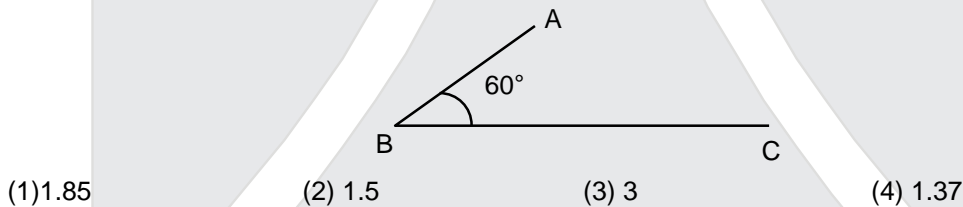

Ans. (4)

Sol.

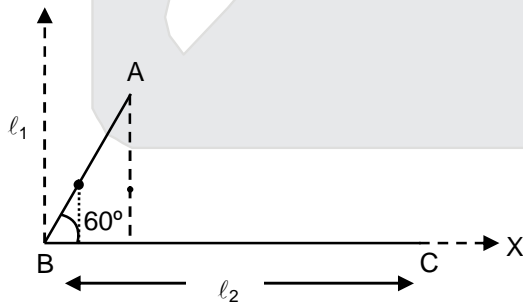

If CM lies vertically below A \Rightarrow as per choose coordinate axis in x-coordinate is equal to $\frac{l_1}{2}$

$$X_{cm} = \frac{m_1 x_1 + m_2 x_2}{m_1 + m_2}$$

RESONANCE EDUVENTURES LTD.

CORPORATE OFFICE : CG TOWER, A-46 & 52, IPIA, NEAR CITY MALL, JHALAWAR ROAD, KOTA (RAJ.) - 324005

REG. OFFICE : J-2, JAWAHAR NAGAR, MAIN ROAD, KOTA (RAJ.)-324005 | PH. NO.: +91-744-3192222 | FAX NO. : +91-022-39167222

PH.NO. : +91-744-3012222, 6635555 | TO KNOW MORE : SMS RESO AT 56677

WEBSITE : WWW.RESONANCE.AC.IN | E-MAIL : CONTACT@RESONANCE.AC.IN | CIN : U80302RJ2007PLC024029

Toll Free : 1800 258 5555 08003 444 888 facebook.com/ResonanceEdu twitter.com/ResonanceEdu www.youtube.com/resowatch blog.resonance.ac.in

$$\frac{l_1}{2} = \frac{(\lambda l_1)\left(\frac{l_1}{4}\right) + (\lambda l_2)\left(\frac{l_2}{2}\right)}{\lambda(l_1 + l_2)}$$

$$\frac{l_1^2}{2} + \frac{l_1 l_2}{2} = \frac{l_1^2}{4} + \frac{l_2^2}{2}$$

$$\frac{l_1^2}{4} + \frac{l_1 l_2}{2} - \frac{l_2^2}{2} = 0$$

$$l_1^2 + 2l_1 l_2 - 2l_2^2 = 0$$

$$l_1 = \frac{-2l_2 \pm \sqrt{4l_1^2 + 4.1(2l_2^2)}}{2}$$

$$l_1 = \frac{-2l_2 + \sqrt{12l_2^2}}{2}$$

$$l_1 = \frac{-2l_2 + 2\sqrt{3}l_2}{2}$$

$$l_1 = (\sqrt{3} - 1) l_2$$

$$\frac{l_2}{l_1} = \frac{1}{\sqrt{3} - 1} \times \frac{\sqrt{3} + 1}{\sqrt{3} + 1}$$

$$\frac{l_2}{l_1} = \frac{\sqrt{3} + 1}{2} = \frac{2.732}{2} = 1.366$$

$$\approx 1.37$$

12. A neutron moving with a speed 'v' makes a head on collision with a stationary hydrogen atom in ground state. The minimum kinetic energy of the neutron for which inelastic collision will take place is :

(1) 10.2 eV (2) 12.1 eV (3) 20.4 eV (4) 16.8eV

Ans. (3)

Sol. Assuming perfectly inelastic collision for maximum loss in K.E.

$$V_f = \frac{V_i}{2}$$

$$\Rightarrow K.E_f = \frac{1}{2} (2m) \frac{V_i^2}{4} \Rightarrow K.E_f = \frac{KE_i}{2}$$

$$\Rightarrow \text{loss} = \frac{KE_i}{2} \Rightarrow \frac{KE_i}{2} \geq 10.2 \text{ eV}$$

$$\Rightarrow K.E_i \geq 20.4 \text{ eV}$$

13. Concrete mixture is made by mixing cement, stone and sand in a rotating cylindrical drum. If the drum rotates too fast, the ingredients remain stuck to the wall of the drum and proper mixing of ingredients does not take place. The maximum rotational speed of the drum in revolutions per minute (rpm) to ensure proper mixing is close to :

(Take the radius of the drum to be 1.25m and its axle to be horizontal):

(1) 1.3 (2) 0.4 (3) 27.0 (4) 8.0

Ans. Bonus





RESONANCE EDUVENTURES LTD.

CORPORATE OFFICE : CG TOWER, A-46 & 52, IPIA, NEAR CITY MALL, JHALAWAR ROAD, KOTA (RAJ.) - 324005

REG. OFFICE : J-2, JAWAHAR NAGAR, MAIN ROAD, KOTA (RAJ.)-324005 | PH. NO.: +91-744-3192222 | FAX NO. : +91-022-39167222

PH.NO. : +91-744-3012222, 6635555 | TO KNOW MORE : SMS RESO AT 56677

WEBSITE : WWW.RESONANCE.AC.IN | E-MAIL : CONTACT@RESONANCE.AC.IN | [CIN : U80302RJ2007PLC024029](http://CIN:U80302RJ2007PLC024029)

Toll Free : 1800 258 5555  08003 444 888  facebook.com/ResonanceEdu  twitter.com/ResonanceEdu  www.youtube.com/resowatch  blog.resonance.ac.in

Sol. $\zeta \leq \sqrt{5gr}$
 $\omega = \frac{v}{r} \leq \sqrt{\frac{5g}{r}} = \sqrt{\frac{50 \times 8}{10}} = \sqrt{\frac{400}{10}}$
 $\omega = \sqrt{40} \text{ rad/s}$
 $= \frac{60\sqrt{10}}{\pi} \text{ rpm}$

14. A photoelectric surface is illuminated successively by monochromatic light of wavelengths λ and $\frac{\lambda}{3}$. If the maximum kinetic energy of the emitted photoelectrons in the second case is 3 times that in the first case, the work function of the surface is :

(1) $\frac{3hc}{\lambda}$ (2) $\frac{hc}{\lambda}$ (3) $\frac{hc}{3\lambda}$ (4) $\frac{hc}{2\lambda}$

Ans. (4)

Sol. $KE_1 = \frac{hc}{\lambda} - W$ (i)
 $3 K.E_1 = \frac{2hc}{\lambda} - W$
 $\Rightarrow K.E_1 = \frac{2hc}{3\lambda} - \frac{W}{3}$ (ii)
 $\Rightarrow \frac{hc}{\lambda} - W = \frac{2hc}{3\lambda} - \frac{W}{3}$
 (Equating (i) & (ii))
 $\Rightarrow \frac{hc}{\lambda} \left(\frac{1}{3}\right) = \frac{2W}{3}$
 $\Rightarrow W = \frac{hc}{2\lambda}$

15. A,B,C and D are four different physical quantities having different dimensions. None of them is dimensionless. But we know that the equation $AD = C \ln (BD)$ holds true. Then which of the combination is not a meaningful quantity ?

(1) $A^2 - B^2 C^2$ (2) $\frac{A}{B} - C$ (3) $\frac{C}{BD} - \frac{AD^2}{C}$ (4) $\frac{(A - C)}{D}$

Ans. (4)

Sol. $AD = C \ln (BD)$
 (B) (D) \rightarrow dimensionless
 $[AD] = [C]$
 Checking options one by one
 $\frac{A - C}{D}$ dimensions of A are not same as dimensions of C.
 meaningless





RESONANCE EDUVENTURES LTD.

CORPORATE OFFICE : CG TOWER, A-46 & 52, IPIA, NEAR CITY MALL, JHALAWAR ROAD, KOTA (RAJ.) - 324005

REG. OFFICE : J-2, JAWAHAR NAGAR, MAIN ROAD, KOTA (RAJ.)-324005 | PH. NO.: +91-744-3192222 | FAX NO. : +91-022-39167222

PH.NO. : +91-744-3012222, 6635555 | TO KNOW MORE : SMS RESO AT 56677

WEBSITE : WWW.RESONANCE.AC.IN | E-MAIL : CONTACT@RESONANCE.AC.IN | CIN : U80302RJ2007PLC024029

Toll Free : 1800 258 5555  08003 444 888  facebook.com/ResonanceEdu  twitter.com/ResonanceEdu  www.youtube.com/resowatch  blog.resonance.ac.in

16. A thin 1m long rod has a radius of 5 mm. A force of 50π kN is applied at one end to determine its Young's modulus. Assume that the force is exactly known. If the least count in the measurement of all lengths is 0.01 mm, which of the following statements is false ?

- (1) The maximum value of Y that can be determined is 10^{14} N/m²
- (2) $\frac{\Delta Y}{Y}$ gets minimum contribution from the uncertainty in the length.
- (3) The figure of merit is the largest for the length of the rod.
- (4) $\frac{\Delta Y}{Y}$ gets its maximum contribution from the uncertainty in strain.

Ans. (1)

Sol.

$$\begin{aligned} \ell &= 1\text{ m} \\ r &= 5 \times 10^{-3}\text{ m} \\ F &= 50\pi \times 10^3\text{ N} \\ \gamma &= \frac{F/A}{\frac{\Delta \ell}{\ell}} \\ \gamma \frac{\Delta \ell}{\ell} &= \frac{F}{A} \\ \gamma &= \frac{50\pi \times 10^3}{\pi \times (5 \times 10^{-3})^2} \times \frac{\ell}{\Delta \ell} \\ \gamma &= \frac{50 \times 10^3}{25 \times 10^{-6}} \times \frac{1}{\Delta \ell} \Rightarrow \gamma = \frac{2 \times 10^9}{\Delta \ell} \\ \gamma &= \frac{2 \times 10^9}{\epsilon} \\ \gamma_{\text{max.}} &= 2 \times 10^9 \end{aligned}$$

17. Figure shows a network of capacitors where the number indicates capacitances in micro Farad. The value of capacitance C if the equivalent capacitance between point A and B is to be $1\mu\text{F}$ is :

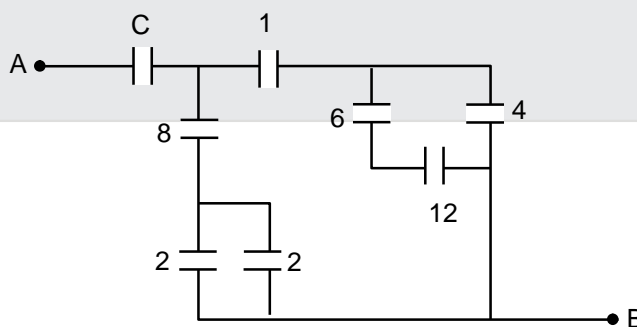

- (1) $\frac{33}{23}\mu\text{F}$
- (2) $\frac{31}{23}\mu\text{F}$
- (3) $\frac{32}{23}\mu\text{F}$
- (4) $\frac{34}{23}\mu\text{F}$

Ans. (3)

RESONANCE EDUVENTURES LTD.

CORPORATE OFFICE : CG TOWER, A-46 & 52, IPIA, NEAR CITY MALL, JHALAWAR ROAD, KOTA (RAJ.) - 324005

REG. OFFICE : J-2, JAWAHAR NAGAR, MAIN ROAD, KOTA (RAJ.)-324005 | PH. NO.: +91-744-3192222 | FAX NO. : +91-022-39167222

PH.NO. : +91-744-3012222, 6635555 | TO KNOW MORE : SMS RESO AT 56677

WEBSITE : WWW.RESONANCE.AC.IN | E-MAIL : CONTACT@RESONANCE.AC.IN | [CIN : U80302RJ2007PLC024029](http://CIN:U80302RJ2007PLC024029)

Toll Free : 1800 258 5555 | 08003 444 888 | facebook.com/ResonanceEdu | twitter.com/ResonanceEdu | www.youtube.com/resowatch | blog.resonance.ac.in

Sol. $\frac{8 \times 12}{18} = 4\mu\text{F}$
 $4\mu\text{F} + 4\mu\text{F} = 8\mu\text{F}$
 $\frac{8 \times 1}{8+1} = \frac{8}{9}\mu\text{F}$
 $\frac{8 \times 4}{8+4} = \frac{32}{12} = \frac{8}{3}\mu\text{F}$
 $\frac{8}{3} + \frac{8}{9} = \frac{24+8}{9} = \frac{32}{9}\mu\text{C}$
 $\frac{\frac{32}{9} \times C}{\frac{32}{9} + C} = 1 \Rightarrow \frac{32}{9} \times C = \frac{32}{9} + C$
 $\Rightarrow C \left(\frac{32-9}{9} \right) = \frac{32}{9}$
 $C = \frac{32}{23}\mu\text{F}$

18. Which of the following shown the correct relationship between the pressure 'P' and density ρ of an ideal gas at constant temperature ?

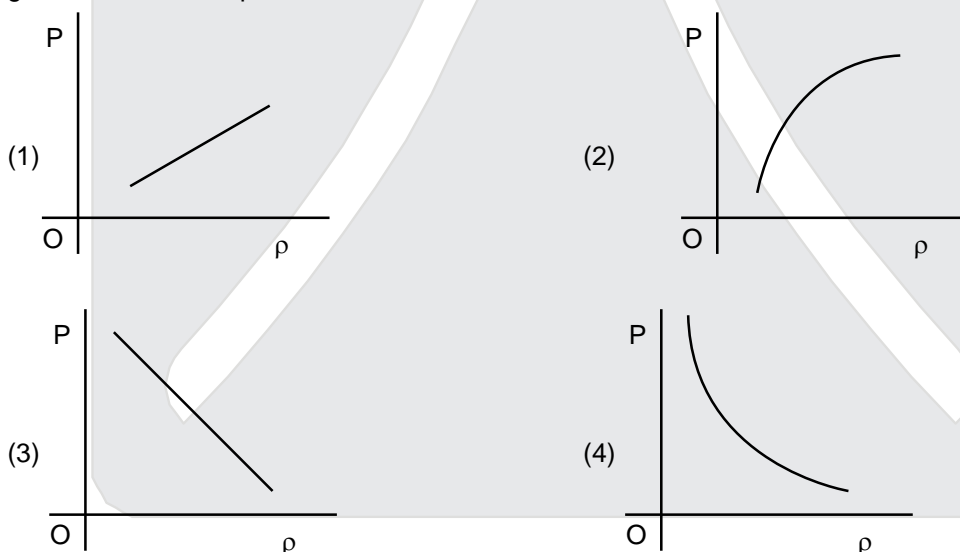

Ans. (1)

Sol. $\rho = \frac{PM}{RT}$
 $P = \frac{\rho RT}{M}$
 $P \propto \rho$

RESONANCE EDUVENTURES LTD.

CORPORATE OFFICE : CG TOWER, A-46 & 52, IPIA, NEAR CITY MALL, JHALAWAR ROAD, KOTA (RAJ.) - 324005

REG. OFFICE : J-2, JAWAHAR NAGAR, MAIN ROAD, KOTA (RAJ.)-324005 | PH. NO.: +91-744-3192222 | FAX NO. : +91-022-39167222

PH.NO. : +91-744-3012222, 6635555 | TO KNOW MORE : SMS RESO AT 56677

WEBSITE : WWW.RESONANCE.AC.IN | E-MAIL : CONTACT@RESONANCE.AC.IN | [CIN : U80302RJ2007PLC024029](http://CIN:U80302RJ2007PLC024029)

Toll Free : 1800 258 5555 08003 444 888 facebook.com/ResonanceEdu twitter.com/ResonanceEdu www.youtube.com/resowatch blog.resonance.ac.in

19. A hemispherical glass body of radius 10cm and refractive index 1.5 is silvered on its curved surface. A small air bubble is 6cm below the flat surface inside it along the axis. The position of the image of the air bubble made by the mirror is seen.:

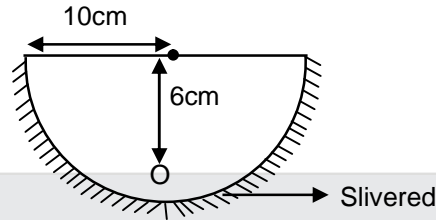

- (1) 20 cm below flat surface
(3) 16 cm below flat surface

- (2) 30 cm below flat surface
(4) 14 cm below flat surface

Ans. (1)

Sol.

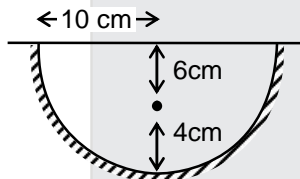

$$\frac{1}{V} + \frac{1}{-4} = \frac{1}{-5}$$

$$\frac{1}{V} = \frac{1}{4} - \frac{1}{5} = \frac{5-4}{20}$$

$$V = 20 \text{ cm}$$

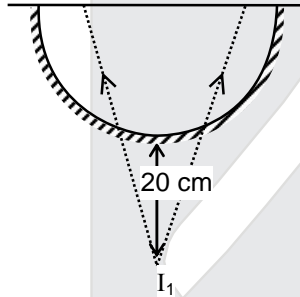

I_1 acts as object for plane surface

$$d' = \frac{d}{n_{rel}} = \frac{30}{1.5}$$

$$d' = \frac{300}{15} = 20 \text{ cm}$$

20 cm below plane surface

RESONANCE EDUVENTURES LTD.

CORPORATE OFFICE : CG TOWER, A-46 & 52, IPIA, NEAR CITY MALL, JHALAWAR ROAD, KOTA (RAJ.) - 324005

REG. OFFICE : J-2, JAWAHAR NAGAR, MAIN ROAD, KOTA (RAJ.)-324005 | PH. NO.: +91-744-3192222 | FAX NO. : +91-022-39167222

PH.NO. : +91-744-3012222, 6635555 | TO KNOW MORE : SMS RESO AT 56677

WEBSITE : WWW.RESONANCE.AC.IN | E-MAIL : CONTACT@RESONANCE.AC.IN | CIN : U80302RJ2007PLC024029

Toll Free : 1800 258 5555 | 08003 444 888 | [facebook.com/ResonanceEdu](https://www.facebook.com/ResonanceEdu) | twitter.com/ResonanceEdu | www.youtube.com/resowatch | blog.resonance.ac.in

20. In an engine the piston undergoes vertical simple harmonic motion with amplitude 7cm. A washer rests on top of the piston and moves with it. The motor speed is slowly increased. The frequency of the piston at which the washer longer stays in contact with the piston, is closed to :

(1) 0.7 Hz (2) 1.2 Hz (3) 1.9 Hz (4) 0.1 Hz

Ans. (3)

Sol. $\omega^2 A = g$ $T = \frac{2\pi}{\omega}$ $\omega = 2\pi f$

$$\omega^2 (0.07) = 10 \text{ m/s}^2$$

$$4\pi^2 f^2 (0.07) = 10 \text{ m/s}^2$$

$$f = \frac{5}{\sqrt{7}} \text{ Hz} = 1.9 \text{ Hz}$$

21. Two stars are 10 light years away from the earth. They are seen through a telescope of objective diameter 30cm. The wavelength of light 600 nm. To see the stars just resolved by the telescope, the minimum distance between them should be (1 light year = 9.46×10^{15} m) of the order of :

(1) 10^8 km (2) 10^6 km (3) 10^{11} km (4) 10^{10} km

Ans. (2)

Sol. $\theta = \frac{1.22\lambda}{D}$

$$\frac{x}{10 \text{ light year}} = \frac{1.22 \times 600 \times 10^{-9}}{30 \times 10^{-2}}$$

$$\frac{x}{10 \text{ light year}} = 24.4 \times 10^{-7}$$

$$x = 2.4 \times 10^{-7} \times 9.46 \times 10^{15} \text{ m}$$

$$23.08 \times 10^6 \text{ km}$$

22. A conducting metal circular -wire loop of radius r is placed perpendicular to a magnetic field which varies with time as $B = B_0 e^{-t/\tau}$, where B_0 and τ are constants, at $t = 0$. If the resistance of the loop is R then the heat generated in the loop after a long time ($t \rightarrow \infty$) is :

(1) $\frac{\pi^2 r^4 B_0^2 R}{\tau}$ (2) $\frac{\pi^2 r^4 B_0^2}{2\tau R}$ (3) $\frac{\pi^2 r^4 B_0^2}{\tau R}$ (4) $\frac{\pi^2 r^4 B_0^2}{2\tau R}$

Ans. (4)

Sol. heat equated = $\int_0^{\infty} i^2 R dt$

$$= \int_0^{\infty} \frac{\varepsilon_{\text{ind}}^2}{Rt} R dt$$

$$= \frac{1}{R} \int_0^{\infty} \varepsilon_{\text{ind}}^2 dt$$

$$= \frac{1}{R} \frac{\pi^2 r^4 B_0^2}{\tau^2} \int_0^{\infty} e^{-2t/\tau} dt$$

$$= \frac{\pi^2 r^4 B_0^2}{R\tau^2} \left. \frac{e^{-2t/\tau}}{-2/\tau} \right|_0^{\infty}$$





RESONANCE EDUVENTURES LTD.

CORPORATE OFFICE : CG TOWER, A-46 & 52, IPIA, NEAR CITY MALL, JHALAWAR ROAD, KOTA (RAJ.) - 324005

REG. OFFICE : J-2, JAWAHAR NAGAR, MAIN ROAD, KOTA (RAJ.)-324005 | PH. NO.: +91-744-3192222 | FAX NO. : +91-022-39167222

PH.NO. : +91-744-3012222, 6635555 | TO KNOW MORE : SMS RESO AT 56677

WEBSITE : WWW.RESONANCE.AC.IN | E-MAIL : CONTACT@RESONANCE.AC.IN | CIN : U80302RJ2007PLC024029

Toll Free : 1800 258 5555  08003 444 888  facebook.com/ResonanceEdu  twitter.com/ResonanceEdu  www.youtube.com/resowatch  blog.resonance.ac.in

$$= + \frac{\pi^2 r^4 B_0^2 \tau}{2R\tau^2} \{0 + 1\}$$

$$\frac{\pi^2 r^4 B_0^2}{2R\tau}$$

23. A particle of mass M is moving in a circle of fixed radius R in such a way that its centripetal acceleration at time t is given by $n^2 R t^2$ where n is a constant. The power delivered to the particle by the force acting on it, is:

- (1) $M n R^2 t^2$ (2) $\frac{1}{2} M n^2 R^2 t^2$ (3) $M n^2 R^2 t$ (4) $M n R^2 t$

Ans. (3)

Sol.

$$\frac{V^2}{R} = n^2 R t^2$$

$$\Rightarrow V^2 = n^2 R^2 t^2$$

$$\Rightarrow V = n R t$$

$$\Rightarrow \frac{dV}{dt} = n R$$

$$P = F_t V$$

$$= \frac{m dV}{dt} V$$

$$= m n R \cdot n R t$$

$$P = n^2 R^2 t m$$

24. The ratio (R) of output resistance r_o , and the input resistance r_i in measurements of input and output characteristics of a transistor is typically in the range :

- (1) $R \sim 0.1 - 0.01$ (2) $R \sim 0.1 - 1.0$ (3) $R \sim 10^2 - 10^3$ (4) $R \sim 1 - 10$

Ans. (4)

Sol. $R = \frac{r_o}{r_i}$
typical value is approximately 10

25. A modulated signal $C_m(t)$ has the form $C_m(t) = 30 \sin 300\pi t + 10 (\cos 200\pi t - \cos 400\pi t)$. The carrier frequency f_c , the modulating frequency (message frequency) f_ω , and the modulation index μ are respectively given by :

- (1) $f_c = 200 \text{ Hz}$; $f_\omega = 30 \text{ Hz}$; $\mu = \frac{1}{2}$ (2) $f_c = 150 \text{ Hz}$; $f_\omega = 50 \text{ Hz}$; $\mu = \frac{2}{3}$
(3) $f_c = 200 \text{ Hz}$; $f_\omega = 50 \text{ Hz}$; $\mu = \frac{1}{2}$ (4) $f_c = 150 \text{ Hz}$; $f_\omega = 30 \text{ Hz}$; $\mu = \frac{1}{3}$

Ans. (2)

Sol. $\ell_m(t) = 30 \sin(300\pi t) + 10 \cos(400\pi t)$

$$f = \frac{\omega}{2\pi} = \frac{300\pi}{2\pi} = 150$$

$$= \frac{20\pi}{2\pi} = 100$$





RESONANCE EDUVENTURES LTD.

CORPORATE OFFICE : CG TOWER, A-46 & 52, IPIA, NEAR CITY MALL, JHALAWAR ROAD, KOTA (RAJ.) - 324005

REG. OFFICE : J-2, JAWAHAR NAGAR, MAIN ROAD, KOTA (RAJ.)-324005 | PH. NO.: +91-744-3192222 | FAX NO. : +91-022-39167222

PH.NO. : +91-744-3012222, 6635555 | TO KNOW MORE : SMS RESO AT 56677

WEBSITE : WWW.RESONANCE.AC.IN | E-MAIL : CONTACT@RESONANCE.AC.IN | [CIN : U80302RJ2007PLC024029](http://CIN:U80302RJ2007PLC024029)

Toll Free : 1800 258 5555 |  08003 444 888 |  facebook.com/ResonanceEdu |  twitter.com/ResonanceEdu |  www.youtube.com/resowatch |  blog.resonance.ac.in

$$\frac{400\pi}{2\pi} = 200$$

$$f_c = 150 \text{ Hz}$$

$$f_m = 50 \text{ Hz}$$

$$\mu = \frac{2}{3}$$

26. The resistance of an electrical toaster has a temperature dependence given by $R(T) = R_0 [1 + \alpha(T - T_0)]$ in its range of operation. At $T_0 = 300 \text{ K}$, $R = 100 \Omega$. And at $T = 500 \text{ K}$, $R = 120 \Omega$. The toaster is connected to a voltage source at 200 V and its temperature is raised at a constant rate from 300 to 500 K in 30 s . The total work done in raising the temperature is :

- (1) $400 \ln \frac{1.5}{1.3} \text{ J}$ (2) 300 J (3) $200 \ln \frac{2}{3} \text{ J}$ (4) $400 \ln \frac{5}{6}$

Ans. Bonus

Sol.

$$\frac{(200)^2}{R_0(1 + \alpha(T - T_0))}$$

$T \rightarrow$ temperature at 't'

$T_0 \rightarrow$ temperature at $t = 300 \text{ K}$

$$T - T_0 = \frac{500 - 300}{30} (t)$$

$$T - T_0 = \frac{200}{30} t$$

$$T - T_0 = \frac{20t}{3}$$

$$\int_0^{30} \frac{(200)^2}{100(1 + \alpha \frac{20t}{3})} dt = \frac{200 \times 200}{100} \int_0^{30} \frac{dt}{1 + \frac{20\alpha}{3} t}$$

$$= \frac{400 \times 3}{20\alpha} \ln \left(\frac{1 + \frac{20\alpha}{3} \times 30}{1} \right)$$

$$120 = 100 (1 + \alpha (200))$$

$$1 + (200) \alpha = \frac{6}{5}$$

$$(200) \alpha = \frac{1}{5}$$

$$\alpha = \frac{1}{1000}$$

$$= 60,000 \ln \left(\frac{6}{5} \right)$$

RESONANCE EDUVENTURES LTD.

CORPORATE OFFICE : CG TOWER, A-46 & 52, IPIA, NEAR CITY MALL, JHALAWAR ROAD, KOTA (RAJ.) - 324005

REG. OFFICE : J-2, JAWAHAR NAGAR, MAIN ROAD, KOTA (RAJ.)-324005 | PH. NO.: +91-744-3192222 | FAX NO. : +91-022-39167222

PH.NO. : +91-744-3012222, 6635555 | TO KNOW MORE : SMS RESO AT 56677

WEBSITE : WWW.RESONANCE.AC.IN | E-MAIL : CONTACT@RESONANCE.AC.IN | CIN : U80302RJ2007PLC024029

Toll Free : 1800 258 5555 |  08003 444 888 |  facebook.com/ResonanceEdu |  twitter.com/ResonanceEdu |  www.youtube.com/resowatch |  blog.resonance.ac.in

27. Consider a thin metallic sheet perpendicular to the plane of the paper moving with speed 'v' in a uniform magnetic field B going into the plane of the paper (see figure) . If charge densities σ_1 and σ_2 are induced on the left and right surfaces, respectively, of the sheet then (ignore fringe effects)

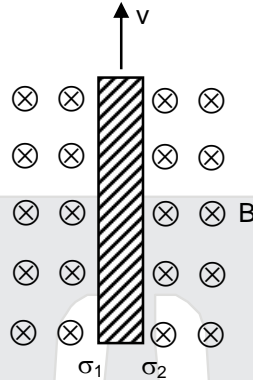

(1) $\sigma_1 = \frac{-\epsilon_0 v B}{2}, \sigma_2 = \frac{-\epsilon_0 v B}{2}$

(2) $\sigma_1 = \sigma_2 = \epsilon_0 v B$

(3) $\sigma_1 = \frac{\epsilon_0 v B}{2}, \sigma_2 = \frac{-\epsilon_0 v B}{2}$

(4) $\sigma_1 = \epsilon_0 v B, \sigma_2 = -\epsilon_0 v B$

Ans. (4)
Sol.

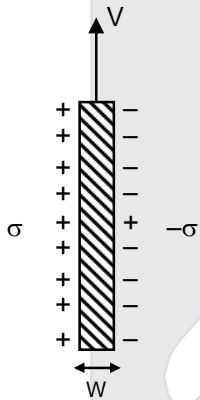

direction of $\vec{V} \times \vec{B}$ is towards left therefore induced charge density will be

$$\text{electric field} = \frac{\sigma}{2\epsilon_0} + \frac{\sigma}{2\epsilon_0} = \frac{\sigma}{\epsilon_0}$$

$$\frac{\sigma}{\epsilon_0} \times W = (B) (V) (\omega)$$

$$\sigma = Bv\epsilon_0$$

RESONANCE EDUVENTURES LTD.

CORPORATE OFFICE : CG TOWER, A-46 & 52, IPIA, NEAR CITY MALL, JHALAWAR ROAD, KOTA (RAJ.) - 324005

REG. OFFICE : J-2, JAWAHAR NAGAR, MAIN ROAD, KOTA (RAJ.)-324005 | PH. NO.: +91-744-3192222 | FAX NO. : +91-022-39167222

PH.NO. : +91-744-3012222, 6635555 | TO KNOW MORE : SMS RESO AT 56677

WEBSITE : WWW.RESONANCE.AC.IN | E-MAIL : CONTACT@RESONANCE.AC.IN | CIN : U80302RJ2007PLC024029

Toll Free : 1800 258 5555 | 08003 444 888 | [facebook.com/ResonanceEdu](https://www.facebook.com/ResonanceEdu) | twitter.com/ResonanceEdu | www.youtube.com/resowatch | blog.resonance.ac.in

28. Velocity-time graph for a body of mass 10 kg is shown in figure . Work-done on the body in first two seconds of the motion is :

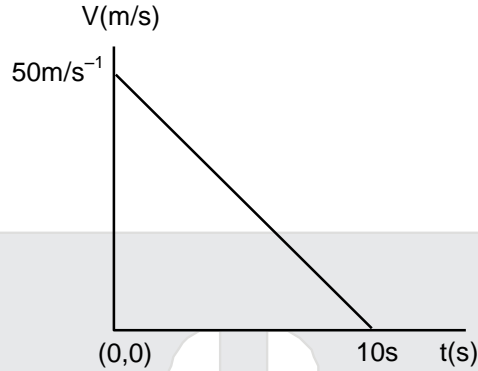

- (1) 12000 J (2) -12000 J (3) -4500 J (4) -9300 J

Ans. (3)
Sol.

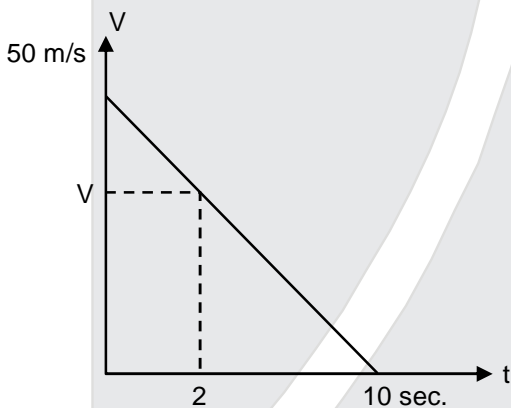

$$\frac{8}{V} = \frac{10}{50}$$

$$V = 40 \text{ m/s}$$

$$W = \frac{1}{2} \times 10 \times (1600 - 2500)$$

$$= \frac{1}{2} \times 10 \times (-900)$$

$$= -4500 \text{ J}$$

29. A toy-car ,blowing its horn, is moving with a steady speed of 5 m/s, away from a wall. An observer, towards whom the toy car is moving, is able to hear 5 beat per second. If the velocity of sound in air is 340 m/s, the frequency of horn of the toy car is close to :

- (1) 340Hz (2) 170 Hz (3) 510 Hz (4) 680 Hz

Ans. (2)





RESONANCE EDUVENTURES LTD.

CORPORATE OFFICE : CG TOWER, A-46 & 52, IPIA, NEAR CITY MALL, JHALAWAR ROAD, KOTA (RAJ.) - 324005

REG. OFFICE : J-2, JAWAHAR NAGAR, MAIN ROAD, KOTA (RAJ.)-324005 | PH. NO.: +91-744-3192222 | FAX NO. : +91-022-39167222

PH.NO. : +91-744-3012222, 6635555 | TO KNOW MORE : SMS RESO AT 56677

WEBSITE : WWW.RESONANCE.AC.IN | E-MAIL : CONTACT@RESONANCE.AC.IN | [CIN : U80302RJ2007PLC024029](http://CIN:U80302RJ2007PLC024029)

Toll Free : 1800 258 5555  08003 444 888  facebook.com/ResonanceEdu  twitter.com/ResonanceEdu  www.youtube.com/resowatch  blog.resonance.ac.in

Sol.

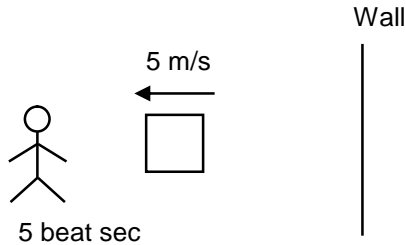

$$f_{\text{dir}} = \left(\frac{340}{340 - 5} \right) f$$

$$f_{\text{ind}} = \left(\frac{340}{340 + 5} \right) f$$

$$f_{\text{ind}} - f_{\text{dir}} = 5$$

$$\left\{ \left(\frac{340}{340 + 5} \right) \left(\frac{340}{340 + 5} \right) \right\} f = 5$$

$$340 \left\{ \frac{10}{(340 - 5)(340 + 5)} \right\} = 5$$

$$f = \frac{340 \times 5}{10}$$

$$f = 170 \text{ Hz}$$

30. Within a spherical charge distribution of charge density $\rho(r)$, N equipotential surfaces of potential $V_0, V_0 + \Delta V, V_0 + 2\Delta V, \dots, V_0 + N\Delta V$ ($\Delta V > 0$), are drawn and have increasing radii $r_0, r_1, r_2, \dots, r_N$, respectively. If the difference in the radii of the surface is constant for all values of V_0 and ΔV then :

(1) $\rho(r) \propto r$

(2) $\rho(r) \propto \frac{1}{r^2}$

(3) $\rho(r) \propto \frac{1}{r}$

(4) $\rho(r) = \text{constant}$

Ans. (3)
Sol.

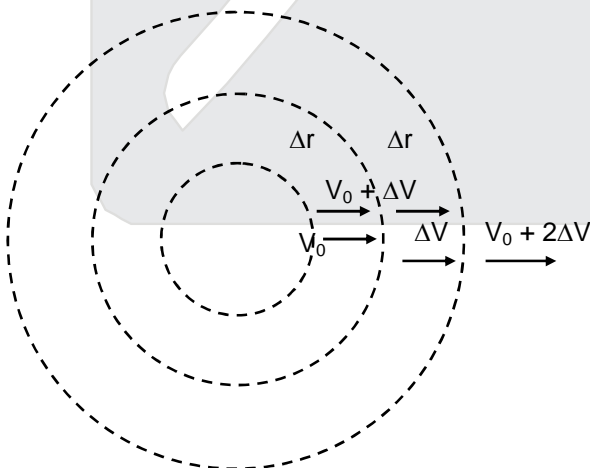

$$\frac{\Delta V}{\Delta r} \rightarrow \text{constant}$$

\Rightarrow uniform E. field.

RESONANCE EDUVENTURES LTD.

CORPORATE OFFICE : CG TOWER, A-46 & 52, IPIA, NEAR CITY MALL, JHALAWAR ROAD, KOTA (RAJ.) - 324005

REG. OFFICE : J-2, JAWAHAR NAGAR, MAIN ROAD, KOTA (RAJ.)-324005 | PH. NO.: +91-744-3192222 | FAX NO. : +91-022-39167222

PH.NO. : +91-744-3012222, 6635555 | TO KNOW MORE : SMS RESO AT 56677

WEBSITE : WWW.RESONANCE.AC.IN | E-MAIL : CONTACT@RESONANCE.AC.IN | CIN : U80302RJ2007PLC024029

Toll Free : 1800 258 5555 | WhatsApp: 08003 444 888 | Facebook: facebook.com/ResonanceEdu | Twitter: twitter.com/ResonanceEdu | YouTube: www.youtube.com/resowatch | Blog: blog.resonance.ac.in

$$(E) (4\pi r^2) = \frac{1}{\epsilon_0} \int \rho dV$$

$$(E) (4\pi r^2) = \frac{1}{\epsilon_0} \int_0^r \rho 4\pi r^2 dr$$

$$(E) (4\pi r^2) = \frac{1}{\epsilon_0} 4\pi \int_0^r \rho r^2 dr$$

after integral on RHS

We must obtain r^2

$$\Rightarrow \rho \propto \frac{1}{r}$$

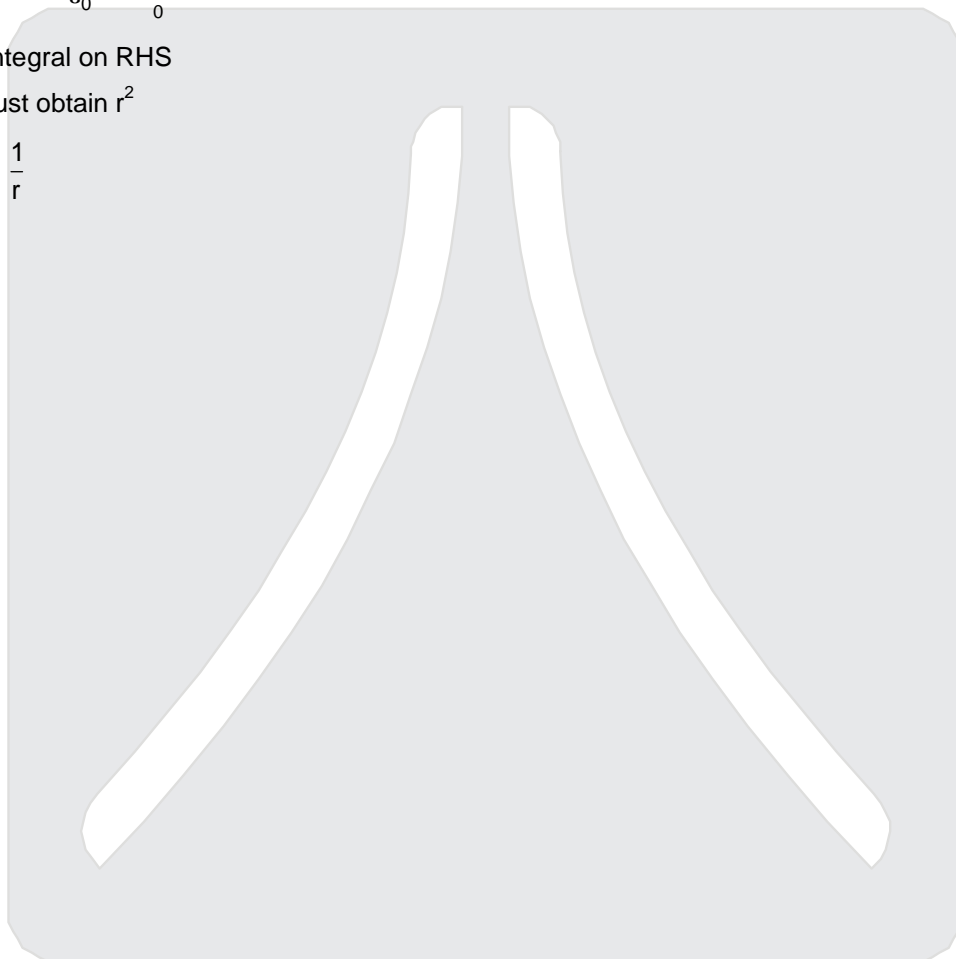





RESONANCE EDUVENTURES LTD.

CORPORATE OFFICE : CG TOWER, A-46 & 52, IPIA, NEAR CITY MALL, JHALAWAR ROAD, KOTA (RAJ.) - 324005

REG. OFFICE : J-2, JAWAHAR NAGAR, MAIN ROAD, KOTA (RAJ.)-324005 | PH. NO.: +91-744-3192222 | FAX NO. : +91-022-39167222

PH.NO. : +91-744-3012222, 6635555 | **TO KNOW MORE** : SMS RESO AT 56677

WEBSITE : WWW.RESONANCE.AC.IN | E-MAIL : CONTACT@RESONANCE.AC.IN | CIN : U80302RJ2007PLC024029

Toll Free : 1800 258 5555  08003 444 888  facebook.com/ResonanceEdu  twitter.com/ResonanceEdu  www.youtube.com/resowatch  blog.resonance.ac.in

Announces

VIVEK

A COMPACT COURSE (CC) of 5 WEEKS*

Short-term Classroom Contact Program (SCCP)

Target: JEE (Advanced) 2016

Compact
with Impact...



Target	Duration	Commencement Date/(Day)	End Date/(Day)
JEE (Advanced) 2016	05 Weeks*	07.04.2016 (Thursday)	14.05.2016 (Saturday)