



Questions & Solutions

PAPER-2 | SUBJECT : PHYSICS

PAPER-2 : INSTRUCTIONS TO CANDIDATES

- Question Paper-2 has three (03) parts : Physics, Chemistry and Mathematics.
- Each part has a total of eighteen (18) questions divided into three (03) sections (Section-1, Section-2 and Section-3).
- Total number of questions in Question Paper-2 are : Fifty Four (54) and Maximum Marks are One Hundred Ninety Eight (198).

Type of Questions and Marking Schemes

SECTION-1 (Maximum Marks: 18)

- This section contains **SIX (06)** questions.
- The answer to each question is a **SINGLE DIGIT INTEGER** ranging from 0 to 9, **BOTH INCLUSIVE**.
- For each question, enter the correct numerical value of the answer using the mouse and the on-screen virtual numeric keypad in the place designated to enter the answer. .
- Answer to each question will be evaluated according to the following marking scheme :
Full Marks : +3 If ONLY the correct numerical value is entered.
Zero Marks : 0 If the question is unanswered.
Negative Marks : -1 In all other cases.

SECTION 2 (Maximum Marks: 24)

- This section contains **SIX (06)** questions.
- Each question has **FOUR** options **ONE OR MORE THAN ONE** of these four option(s) is(are) correct answer(s).
- For each question, choose the option(s) corresponding to (all) the correct answer(s).
- Answer to each question will be evaluated according to the following marking scheme.
Full Marks : +4 If only (all) the correct option(s) is (are) chosen.
Partial Marks : +3 If all the four options are correct but ONLY three options are chosen.
Partial Marks : +2 If three or more options are correct but ONLY two options are chosen and both of which are correct.
Partial Marks : +1 If two or more options are correct but ONLY one option is chosen and it is a correct option.
Zero Marks : 0 If none of the options is chosen (i.e. the question is unanswered).
Negative Marks : -2 In all other cases.

SECTION 3 (Maximum Marks : 24)

- This section contains **SIX (06)** questions. The answer to each question is a **NUMERICAL VALUE**.
- For each question, enter the correct numerical value of the answer using the mouse and the on-screen virtual numeric keypad in the place designated to enter the answer. If the numerical value has more than two decimal places, **truncate/round-off** the value to **TWO** decimal places.
- Answer to each question will be evaluated according to the following marking scheme :
Full Marks : +4 If ONLY the correct numerical value is entered.
Zero Marks : 0 In all other cases.

Resonance Eduventures Limited

REGISTERED & CORPORATE OFFICE : CG Tower, A-46 & 52, IPIA, Near City Mall, Jhalawar Road, Kota (Raj.) - 324005

Ph.No. : 0744-2777777, 0744-2777700 | Toll Free : 1800 258 5555 | FAX No. : +91-022-39167222 | To Know more : sms RESO at 56677

Website : www.resonance.ac.in | E-mail : contact@resonance.ac.in | CIN : U80302RJ2007PLC024029

Toll Free : 1800 258 5555 73400 10333 facebook.com/ResonanceEdu twitter.com/ResonanceEdu www.youtube.com/resowatch blog.resonance.ac.in

This solution was download from Resonance JEE (ADVANCED) 2020 Solution portal

Many Dreamers... Many Achievers...



It's your turn now!

ADMISSION OPEN FOR SESSION 2020-21

ONLINE + OFFLINE PROGRAMS

TARGET

JEE (Main+Advanced) 2021

COURSE

VIJAY

TARGET

JEE (Main) 2021

COURSE

AJAY

TARGET

NEET 2021

COURSE

SAFAL

Scholarship upto 90%* on JEE (Main) Rank, NEET %ile Score & Board%

To know your scholarship: sms RESO <space> SCH & send it to 56677

Digital Learning

For Class
7th to 12th +

Salient features



Live Interactive Classes & Recorded Lectures



Online Study Material & DPPs (Daily Practice Problems)



Discussion & Doubt Clearing Classes (Every week for each subject)



CBT - Computer Based Test & Performance Analysis



Discussion Forum for Doubt Clearing & Additional Learning

*Presently classes would be offered Online and Offline classes would resume as per Government Guidelines.

Toll Free: 1800 258 5555 | Visit us: www.resonance.ac.in



PART : PHYSICS

SECTION-1 (Maximum Marks: 18)

- This section contains **SIX (06)** questions.
- The answer to each question is a **SINGLE DIGIT INTEGER** ranging from **0 to 9, BOTH INCLUSIVE**.
- For each question, enter the correct numerical value of the answer using the mouse and the on-screen virtual numeric keypad in the place designated to enter the answer. .
- Answer to each question will be evaluated according to the following marking scheme :
Full Marks : +3 If ONLY the correct numerical value is entered.
Zero Marks : 0 If the question is unanswered.
Negative Marks : -1 In all other cases.

1. A large square container with thin transparent vertical walls and filled with water (refractive index $\frac{4}{3}$) is kept on a horizontal table. A student holds a thin straight wire vertically inside the water 12 cm from one of its corners, as shown schematically in the figure. Looking at the wire from this corner, another student sees two images of the wire, located symmetrically on each side of the line of sight as shown. The separation (in cm) between these images is _____.

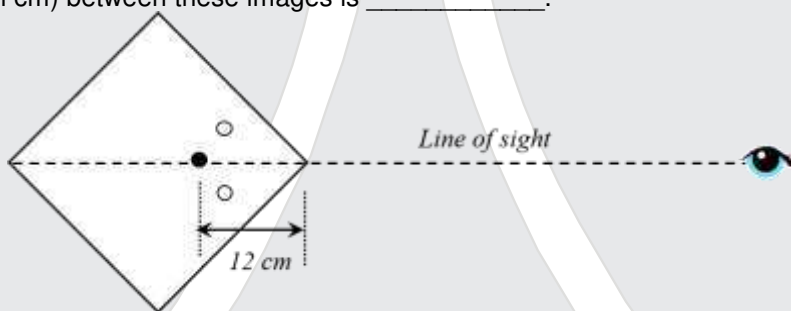

Ans. 3 or Bonus

Sol. $P_1O = \frac{12}{\sqrt{2}}$

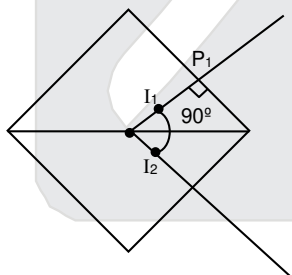

$$P_1I_1 = \frac{12}{\sqrt{2} \times \frac{4}{3}} = \frac{9}{\sqrt{2}}$$

$$OI_1 = \frac{12}{\sqrt{2}} - \frac{9}{\sqrt{2}} = \frac{3}{\sqrt{2}} ; OI_2 = \frac{3}{\sqrt{2}}$$

$$I_1I_2 = \frac{3}{\sqrt{2}} \times \frac{1}{\sqrt{2}} \times 2 = 3.$$

The above solution is assumed according to the normal incidence. If we consider the actual angle of incidence, i.e., 45° the answer comes to be 12.

Resonance Eduventures Ltd.

Reg. Office & Corp. Office : CG Tower, A-46 & 52, IPIA, Near City Mall, Jhalawar Road, Kota (Raj.) - 324005

Ph. No.: +91-744-2777777, 2777700 | FAX No. : +91-022-39167222

To Know more : sms RESO at 56677 | Website : www.resonance.ac.in | E-mail : contact@resonance.ac.in | CIN : U80302RJ2007PLC024029

Toll Free : 1800 258 5555 | 7340010333 | facebook.com/ResonanceEdu | twitter.com/ResonanceEdu | www.youtube.com/resowatch | blog.resonance.ac.in

2. A train with cross-sectional area S_t is moving with speed v_t inside a long tunnel of cross-sectional area S_0 ($S_0 = 4S_t$). Assume that almost all the air (density ρ) in front of the train flows back between its sides and the walls of the tunnel. Also, the air flow with respect to the train is steady and laminar. Take the ambient pressure and that inside the train to be p_0 . If the pressure in the region between the sides of the train and the tunnel walls is p , then $p_0 - p = \frac{7}{2N} \rho v_t^2$. The value of N is _____.

Ans. 9
Sol.

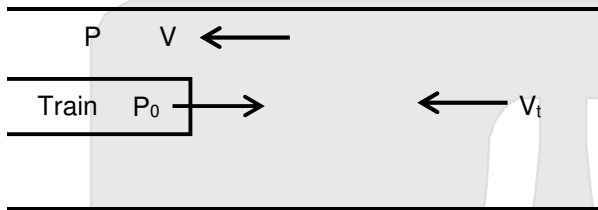

$$4S_t v_t = (3S_t)V$$

$$V = \frac{4}{3} v_t$$

Apply Bernoulli's theorem

$$P_0 + \frac{1}{2} \rho v_t^2 = P + \frac{1}{2} \rho \left(\frac{4}{3} v_t \right)^2$$

$$P_0 - P = \frac{7}{18} \rho v_t^2$$

$$\Rightarrow N = 9.$$

3. Two large circular discs separated by a distance of 0.01 m are connected to a battery via a switch as shown in the figure. Charged oil drops of density 900 kg m^{-3} are released through a tiny hole at the center of the top disc. Once some oil drops achieve terminal velocity, the switch is closed to apply a voltage of 200 V across the discs. As a result, an oil drop of radius $8 \times 10^{-7} \text{ m}$ stops moving vertically and floats between the discs. The number of electrons present in this oil drop is _____. (neglect the buoyancy force, take acceleration due to gravity = 10 ms^{-2} and charge on an electron (e) = $1.6 \times 10^{-19} \text{ C}$)

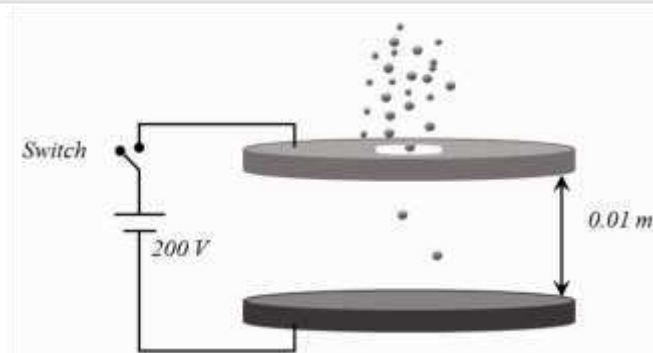

Ans. 6

Resonance Eduventures Ltd.

Reg. Office & Corp. Office : CG Tower, A-46 & 52, IPIA, Near City Mall, Jhalawar Road, Kota (Raj.) - 324005

Ph. No.: +91-744-2777777, 2777700 | FAX No. : +91-022-39167222

To Know more : sms RESO at 56677 | Website : www.resonance.ac.in | E-mail : contact@resonance.ac.in | CIN : U80302RJ2007PLC024029

Toll Free : 1800 258 5555 | [facebook.com/ResonanceEdu](https://www.facebook.com/ResonanceEdu) | twitter.com/ResonanceEdu | www.youtube.com/resowatch | blog.resonance.ac.in

Sol. $qE = mg$

$$q = \frac{mg}{E} = \frac{900 \times \frac{4}{3} \pi (8 \times 10^{-7})^3 \times 10}{\left(\frac{200}{0.01}\right)}$$

$$= \frac{900 \times \frac{4}{3} \pi \times 512 \times 10^{-21} \times 10}{2 \times 10^4}$$

$$N = \frac{900 \times \frac{4}{3} \pi \times 512 \times 10^{-21} \times 10}{2 \times 10^4 \times 1.6 \times 10^{-19}}$$

$$N \approx 6$$

4. A hot air balloon is carrying some passengers, and a few sandbags of mass 1 kg each so that its total mass is 480 kg. Its effective volume giving the balloon its buoyancy is V . The balloon is floating at an equilibrium height of 100 m. When N number of sandbags are thrown out, the balloon rises to a new equilibrium height close to 150 m with its volume V remaining unchanged. If the variation of the density of air with height h from the ground is $\rho(h) = \rho_0 e^{-\frac{h}{h_0}}$, where $\rho_0 = 1.25 \text{ kg m}^{-3}$ and $h_0 = 6000 \text{ m}$, the value of N is _____.

Ans. 4

Sol. Initially
 $mg = F_b$

$$480 \times g = v \left(\rho_0 e^{-\frac{100}{6000}} \right) g \quad \dots\dots(1)$$

$$\text{Finally } (480 - m)g = v \left(\rho_0 e^{-\frac{150}{6000}} \right) g \quad \dots\dots(2)$$

$$\text{dividing } \frac{480 - m}{480} = e^{\frac{1}{40} - \frac{1}{60}}$$

$$m = 480 (1 - e^{-1/120})$$

$$\text{Hence } e^{-1/120} \approx 1 - \frac{1}{120}$$

$$1 - e^{-1/110} = \frac{1}{120}$$

$$m = 4 \text{ kg}$$

\therefore 4 sand bag is thrown.

Resonance Eduventures Ltd.

Reg. Office & Corp. Office : CG Tower, A-46 & 52, IPIA, Near City Mall, Jhalawar Road, Kota (Raj.) - 324005

Ph. No.: +91-744-2777777, 2777700 | FAX No. : +91-022-39167222

To Know more : sms RESO at 56677 | Website : www.resonance.ac.in | E-mail : contact@resonance.ac.in | CIN : U80302RJ2007PLC024029

Toll Free : 1800 258 5555 | [facebook.com/ResonanceEdu](https://www.facebook.com/ResonanceEdu) | twitter.com/ResonanceEdu | www.youtube.com/resowatch | blog.resonance.ac.in

5. A point charge q of mass m is suspended vertically by a string of length ℓ . A point dipole of dipole moment \vec{p} is now brought towards q from infinity so that the charge moves away. The final equilibrium position of the system including the direction of the dipole, the angles and distances is shown in the figure below. If the work done in bringing the dipole to this position is $N \times (mgh)$, where g is the acceleration due to gravity, then the value of N is _____. (Note that for three coplanar forces keeping a point mass in equilibrium, $\frac{F}{\sin \theta}$ is the same for all forces, where F is any one of the forces and θ is the angle between the other two forces)

Ans. 2
Sol.

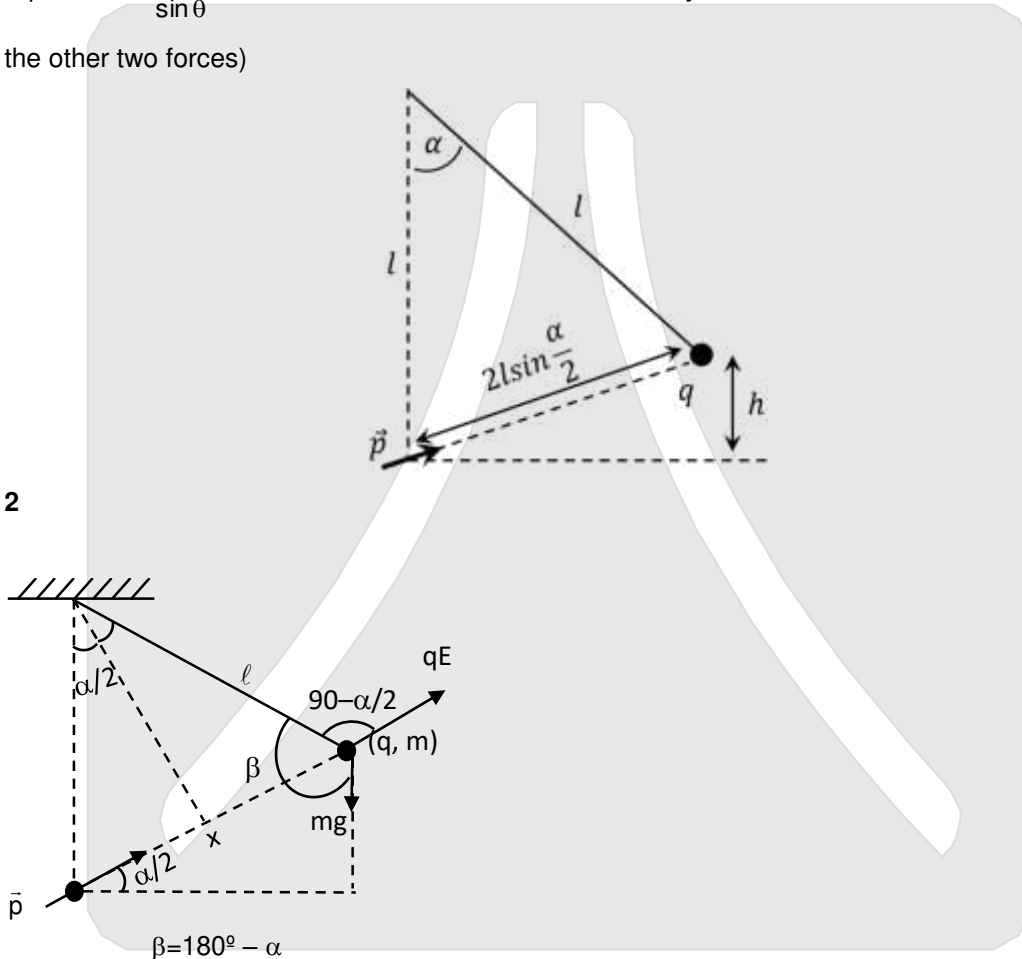

$$W = q \cdot v + mgh$$

$$= q \cdot \frac{kp}{x^2} + mgh \quad \dots(1)$$

For equilibrium

$$\frac{qE}{\sin \beta} = \frac{mg}{\sin \left(90 - \frac{\alpha}{2} \right)}$$

Resonance Eduventures Ltd.

Reg. Office & Corp. Office : CG Tower, A-46 & 52, IPIA, Near City Mall, Jhalawar Road, Kota (Raj.) - 324005

Ph. No.: +91-744-2777777, 2777700 | FAX No. : +91-022-39167222

To Know more : sms RESO at 56677 | Website : www.resonance.ac.in | E-mail : contact@resonance.ac.in | CIN : U80302RJ2007PLC024029

Toll Free : 1800 258 5555 | [facebook.com/ResonanceEdu](https://www.facebook.com/ResonanceEdu) | twitter.com/ResonanceEdu | www.youtube.com/resowatch | blog.resonance.ac.in

$$\frac{qE}{\sin(180-\alpha)} = \frac{mg}{\cos\left(\frac{\alpha}{2}\right)} ; \quad \frac{qE}{\sin\alpha} = \frac{mg}{\cos\frac{\alpha}{2}}$$

$$\frac{qE}{2\sin\frac{\alpha}{2}\cos\frac{\alpha}{2}} = \frac{mg}{\cos\frac{\alpha}{2}} ; \quad qE = mg2\sin\left(\frac{\alpha}{2}\right)$$

$$q\left(\frac{kp}{x^2}\right) = mgx\sin\frac{\alpha}{2} = mg\sin\left(\frac{\alpha}{2}\right) \cdot \frac{h}{\sin\frac{\alpha}{2}}$$

$$q\frac{kp}{x^2} = mgh \quad \dots(ii)$$

From (i) and (ii)

$$W = 2mgh$$

$$x = 2$$

6. A thermally isolated cylindrical closed vessel of height 8 m is kept vertically. It is divided into two equal parts by a diathermic (perfect thermal conductor) frictionless partition of mass 8.3 kg. Thus the partition is held initially at a distance of 4 m from the top, as shown in the schematic figure below. Each of the two parts of the vessel contains 0.1 mole of an ideal gas at temperature 300 K. The partition is now released and moves without any gas leaking from one part of the vessel to the other. When equilibrium is reached, the distance of the partition from the top (in m) will be _____ (take the acceleration due to gravity = 10 ms⁻² and the universal gas constant = 8.3 J mol⁻¹K⁻¹).

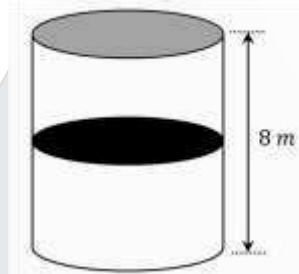

- Ans. 6**
Sol. Initially $PA(4) = 0.1 \times R \times 300$ (i) for both part
Let final distance of piston from top is 'y'
 $0.1 \times R \times 300 = P_1 \times A \cdot y = P_2 A(8 - y)$ (ii)

$$P_1A + 8.3g = P_2A$$

$$\frac{30R}{y} + 8.3g = \frac{30R}{8-y}$$

$$\frac{30}{y} + 10 = \frac{30}{8-y} ;$$

$$\frac{3+y}{y} = \frac{3}{8-y}$$

$$24 + 8y - 3y - y^2 = 3y$$

$$y^2 - 2y - 24 = 0 ; \quad y = \frac{2 \pm \sqrt{4+96}}{2 \times 1} = \frac{2 \pm 10}{2} = 6m.$$

Resonance Eduventures Ltd.

Reg. Office & Corp. Office : CG Tower, A-46 & 52, IPIA, Near City Mall, Jhalawar Road, Kota (Raj.) - 324005

Ph. No.: +91-744-2777777, 2777700 | FAX No. : +91-022-39167222

To Know more : sms RESO at 56677 | Website : www.resonance.ac.in | E-mail : contact@resonance.ac.in | CIN : U80302RJ2007PLC024029

Toll Free : 1800 258 5555 | 7340010333 | facebook.com/ResonanceEdu | twitter.com/ResonanceEdu | www.youtube.com/resowatch | blog.resonance.ac.in

SECTION 2 (Maximum Marks: 24)

- This section contains **SIX (06)** questions.
- Each question has **FOUR** options **ONE OR MORE THAN ONE** of these four option(s) is(are) correct answer(s).
- For each question, choose the option(s) corresponding to (all) the correct answer(s).
- Answer to each question will be evaluated according to the following marking scheme.

Full Marks : +4 If only (all) the correct option(s) is (are) chosen.

Partial Marks : +3 If all the four options are correct but ONLY three options are chosen.

Partial Marks : +2 If three or more options are correct but ONLY two options are chosen and both of which are correct.

Partial Marks : +1 If two or more options are correct but ONLY one option is chosen and it is a correct option.

Zero Marks : 0 If none of the options is chosen (i.e. the question is unanswered).

Negative Marks : -2 In all other cases.

7. A beaker of radius r is filled with water (refractive index $\frac{4}{3}$) up to a height H as shown in the figure on the left. The beaker is kept on a horizontal table rotating with angular speed ω . This makes the water surface curved so that the difference in the height of water level at the center and at the circumference of the beaker is h ($h \ll H$, $h \ll r$), as shown in the figure on the right. Take this surface to be approximately spherical with a radius of curvature R . Which of the following is/are correct ? (g is acceleration due to gravity)

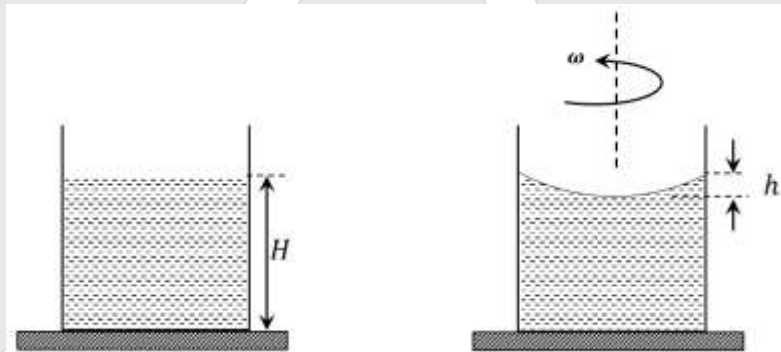

(A) $R = \frac{h^2 + r^2}{2h}$

(B) $R = \frac{3r^2}{2h}$

(C) Apparent depth of the bottom of the beaker is close to $\frac{3H}{2} \left(1 + \frac{\omega^2 H}{2g}\right)^{-1}$

(D) Apparent depth of the bottom of the beaker is close to $\frac{3H}{4} \left(1 + \frac{\omega^2 H}{4g}\right)^{-1}$

Ans. (AD)

Resonance Eduventures Ltd.

Reg. Office & Corp. Office : CG Tower, A-46 & 52, IPIA, Near City Mall, Jhalawar Road, Kota (Raj.) - 324005

Ph. No.: +91-744-2777777, 2777700 | FAX No. : +91-022-39167222

To Know more : sms RESO at 56677 | Website : www.resonance.ac.in | E-mail : contact@resonance.ac.in | CIN : U80302RJ2007PLC024029

Toll Free : 1800 258 5555 7340010333 facebook.com/ResonanceEdu twitter.com/ResonanceEdu www.youtube.com/resowatch blog.resonance.ac.in

Sol.

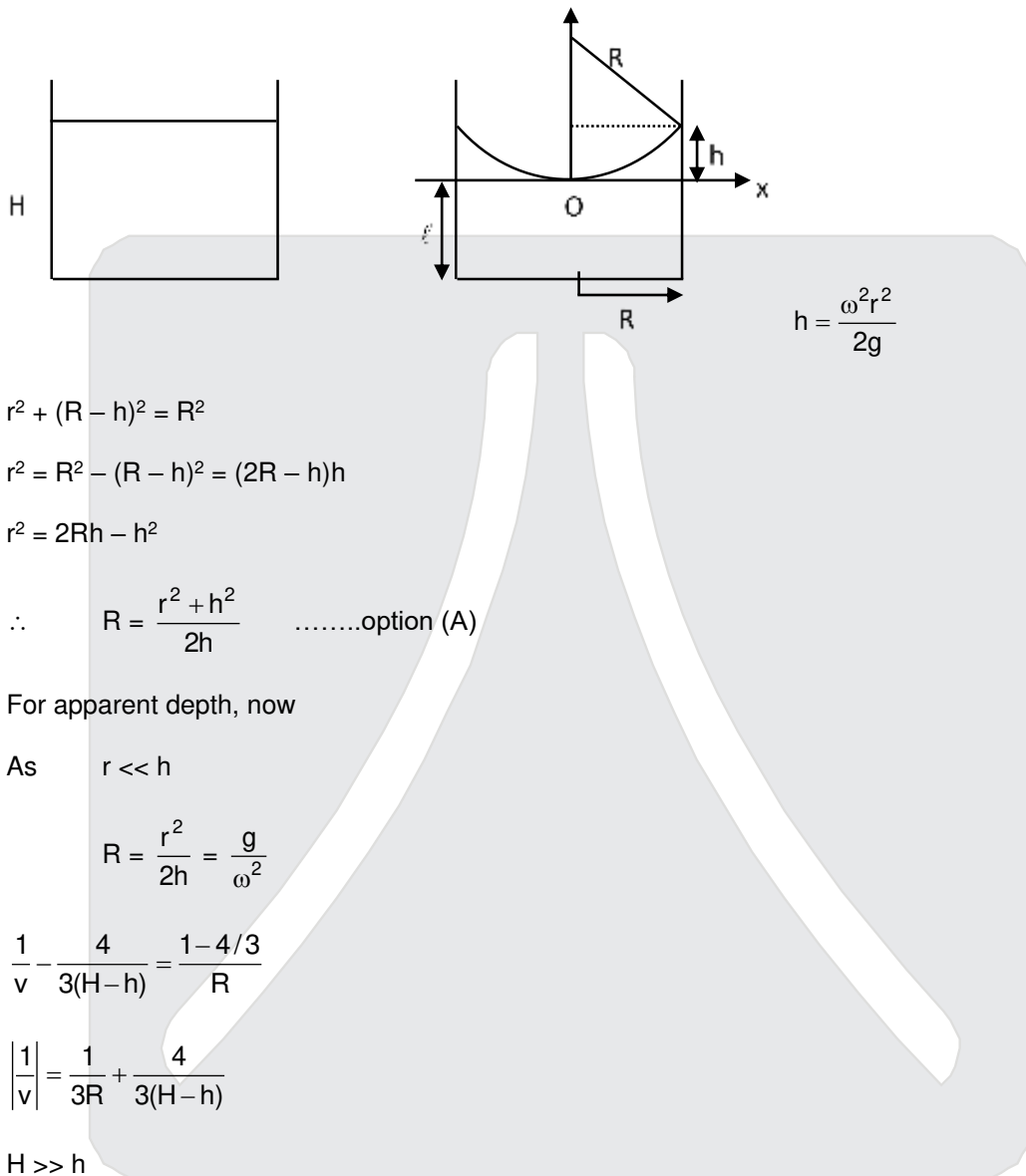

$$r^2 + (R - h)^2 = R^2$$

$$r^2 = R^2 - (R - h)^2 = (2R - h)h$$

$$r^2 = 2Rh - h^2$$

$$\therefore R = \frac{r^2 + h^2}{2h} \quad \text{.....option (A)}$$

For apparent depth, now

As $r \ll h$

$$R = \frac{r^2}{2h} = \frac{g}{\omega^2}$$

$$\frac{1}{v} - \frac{4}{3(H-h)} = \frac{1-4/3}{R}$$

$$\left| \frac{1}{v} \right| = \frac{1}{3R} + \frac{4}{3(H-h)}$$

$H \gg h$

$$\left| \frac{1}{v} \right| = \frac{\omega^2}{3g} + \frac{4}{3H} = \frac{4}{3H} \left[1 + \frac{3H}{4} \times \frac{\omega^2}{3g} \right]$$

$$|V| = \frac{3H}{4} \left[1 + \frac{\omega^2 H}{4g} \right]^{-1} \quad \text{.....option (D)}$$

Resonance Eduventures Ltd.

Reg. Office & Corp. Office : CG Tower, A-46 & 52, IPIA, Near City Mall, Jhalawar Road, Kota (Raj.) - 324005

Ph. No.: +91-744-2777777, 2777700 | FAX No. : +91-022-39167222

To Know more : sms RESO at 56677 | Website : www.resonance.ac.in | E-mail : contact@resonance.ac.in | CIN : U80302RJ2007PLC024029

Toll Free : 1800 258 5555 7340010333 facebook.com/ResonanceEdu twitter.com/ResonanceEdu www.youtube.com/resowatch blog.resonance.ac.in

8. A student skates up a ramp that makes an angle 30° with the horizontal. He/she starts (as shown in the figure) at the bottom of the ramp with speed v_0 and wants to turn around over a semicircular path xyz of radius R during which he/she reaches a maximum height h (at point y) from the ground as shown in the figure. Assume that the energy loss is negligible and the force required for this turn at the highest point is provided by his/her weight only. Then (g is the acceleration due to gravity)

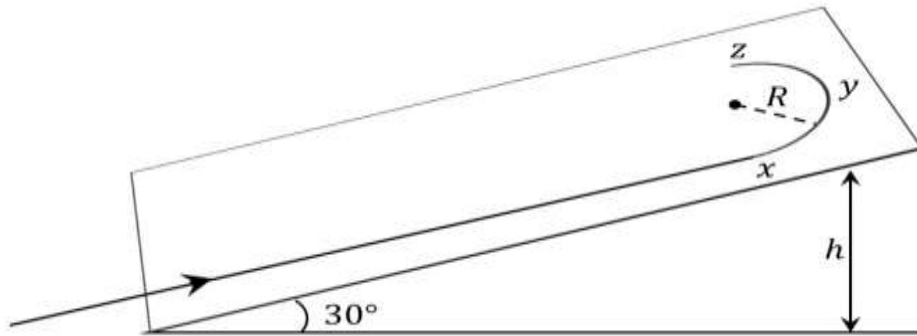

(A) $v_0^2 - 2gh = \frac{1}{2}gR$

(B) $v_0^2 - 2gh = \frac{\sqrt{3}}{2}gR$

(C) the centripetal force required at points x and z is zero

(D) the centripetal force required is maximum at points x and z

Ans. (A, D)

Sol. Speed at x and z is equal and also maximum in circular track

From Energy conservation

$$\frac{1}{2}mv_0^2 = mgh + \frac{1}{2}mv^2 \dots(1)$$

at y $mgsin30^\circ = \frac{mv^2}{R}$

$$v^2 = \frac{2g}{2}$$

∴ From equation (1)

$$v_0^2 - 2gh = \frac{Rg}{2}$$

Resonance Eduventures Ltd.

Reg. Office & Corp. Office : CG Tower, A-46 & 52, IPIA, Near City Mall, Jhalawar Road, Kota (Raj.) - 324005

Ph. No.: +91-744-2777777, 2777700 | FAX No. : +91-022-39167222

To Know more : sms RESO at 56677 | Website : www.resonance.ac.in | E-mail : contact@resonance.ac.in | CIN : U80302RJ2007PLC024029

Toll Free : 1800 258 5555 | [facebook.com/ResonanceEdu](https://www.facebook.com/ResonanceEdu) | twitter.com/ResonanceEdu | www.youtube.com/resowatch | blog.resonance.ac.in

9. A rod of mass m and length L , pivoted at one of its ends, is hanging vertically. A bullet of the same mass moving at speed v strikes the rod horizontally at a distance x from its pivoted end and gets embedded in it. The combined system now rotates with angular speed ω about the pivot. The maximum angular speed ω_M is achieved for $x = x_M$. Then

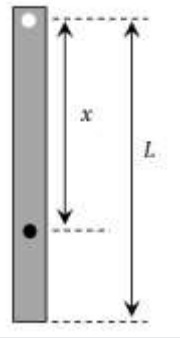

(A) $\omega = \frac{3vx}{L^2 + 3x^2}$ (B) $\omega = \frac{12vx}{L^2 + 12x^2}$ (C) $x_M = \frac{1}{\sqrt{3}}$ (D) $\omega_M = \frac{v}{2L}\sqrt{3}$

Ans. (A, C, D)

Sol. From angular momentum conservation

$$mvx = \left(\frac{ML^2}{3} + mx^2 \right) \omega$$

$$\omega = \frac{3vx}{L^2 + 3x^2}$$

For maximum angular velocity

$$\frac{d\omega}{dx} = 0$$

$$\frac{d}{dx} \left(\frac{L^2}{x} + 3x \right) = 0 \quad ; \quad \frac{-L^2}{x^2} + 3 = 0 \quad ; \quad x = \frac{L}{\sqrt{3}}$$

$$\omega_{\max} = \frac{\sqrt{3}v}{2L}$$

10. In an X-ray tube, electrons emitted from a filament (cathode) carrying current I hit a target (anode) at a distance d from the cathode. The target is kept at a potential V higher than the cathode resulting in emission of continuous and characteristic X-rays. If the filament current I is decreased to $\frac{I}{2}$, the potential

difference V is increased to $2V$, and the separation distance d is reduced to $\frac{d}{2}$, then

- (A) the cut-off wavelength will reduce to half, and the wavelengths of the characteristic X-rays will remain the same
 (B) the cut-off wavelength as well as the wavelengths of the characteristic X-rays will remain the same
 (C) the cut-off wavelength will reduce to half, and the intensities of all the X-rays will decrease
 (D) the cut-off wavelength will become two times larger, and the intensity of all the X-rays will decrease

Ans. (AC)

Resonance Eduventures Ltd.

Reg. Office & Corp. Office : CG Tower, A-46 & 52, IPIA, Near City Mall, Jhalawar Road, Kota (Raj.) - 324005

Ph. No.: +91-744-2777777, 2777700 | FAX No. : +91-022-39167222

To Know more : sms RESO at 56677 | Website : www.resonance.ac.in | E-mail : contact@resonance.ac.in | CIN : U80302RJ2007PLC024029

Toll Free : 1800 258 5555 | [facebook.com/ResonanceEdu](https://www.facebook.com/ResonanceEdu) | twitter.com/ResonanceEdu | www.youtube.com/resowatch | blog.resonance.ac.in

Sol. Cut off wavelength $\lambda_c \propto \frac{1}{V}$

So cut-off wavelength becomes half

Characteristic x-ray depends on target atomic number so it remains same

On decreasing filament current number of electron decrease so intensity of x-ray decreases.

11. Two identical non-conducting solid spheres of same mass and charge are suspended in air from a common point by two non-conducting, massless strings of same length. At equilibrium, the angle between the strings is α . The spheres are now immersed in a dielectric liquid of density 800 kg m^{-3} and dielectric constant 21. If the angle between the strings remains the same after the immersion, then

- (A) electric force between the spheres remains unchanged
- (B) electric force between the spheres reduces
- (C) mass density of the spheres is 840 kg m^{-3}
- (D) the tension in the strings holding the spheres remains unchanged

Ans. (AC)
Sol.

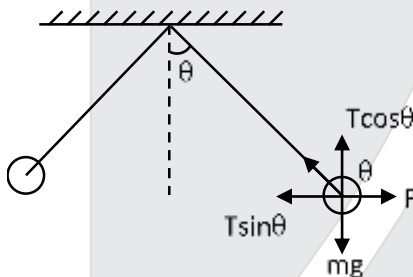

$$T \sin \theta = F \quad ; \quad T \cos \theta = mg$$

Divide

$$\tan \theta = \frac{F}{mg} \quad \dots(1)$$

As force between two charge bodies don't upon medium hence, the force between them remain same because the distance spheres is same.

When it is submerged in liquid then $T' \sin \theta = \frac{F}{\epsilon_r}$

$$T' \cos \theta = mg \left(1 - \frac{\rho_l}{\rho_s} \right)$$

Divide

$$\tan \theta = \frac{F}{mg \left(1 - \frac{\rho_l}{\rho_s} \right)} \epsilon_r \quad \dots(2)$$

Equating (1) & (2)

$$1 - \frac{\rho_l}{\rho_s} = \frac{1}{\epsilon_r} \quad ; \quad 1 - \frac{800}{\rho_s} = \frac{1}{21}$$

$$\rho_s = 840 \text{ kg/m}^3$$

$$T' = \frac{T}{\epsilon_r} = \frac{T}{21}$$

Resonance Eduventures Ltd.

Reg. Office & Corp. Office : CG Tower, A-46 & 52, IPIA, Near City Mall, Jhalawar Road, Kota (Raj.) - 324005

Ph. No.: +91-744-2777777, 2777700 | FAX No. : +91-022-39167222

To Know more : sms RESO at 56677 | Website : www.resonance.ac.in | E-mail : contact@resonance.ac.in | CIN : U80302RJ2007PLC024029

Toll Free : 1800 258 5555 | [facebook.com/ResonanceEdu](https://www.facebook.com/ResonanceEdu) | twitter.com/ResonanceEdu | www.youtube.com/resowatch | blog.resonance.ac.in

12. Starting at time $t = 0$ from the origin with speed 1 ms^{-1} , a particle follows a two-dimensional trajectory in the x - y plane so that its coordinates are related by the equation $y = \frac{x^2}{2}$. The x and y components of its acceleration are denoted by a_x and a_y , respectively. Then
- (A) $a_x = 1 \text{ ms}^{-2}$ implies that when the particle is at the origin, $a_y = 1 \text{ ms}^{-2}$
- (B) $a_x = 0$ implies $a_y = 1 \text{ ms}^{-2}$ at all times
- (C) at $t = 0$, the particle's velocity points in the x -direction
- (D) $a_x = 0$ implies that at $t = 1 \text{ s}$, the angle between the particle's velocity and the x axis is 45°

Ans. (BCD)
Sol.

$$y = \frac{x^2}{2}$$

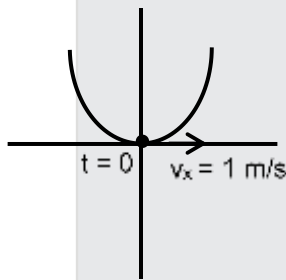

$$\frac{dy}{dt} = \frac{1}{2} \times 2x \frac{dx}{dt}$$

$$v_y = xv_x$$

$$\frac{dv_y}{dt} = \frac{dx}{dt} \times \frac{dx}{dt} + x \left(\frac{d^2v_x}{dt^2} \right)$$

$$a_y = v_x^2 + xa_x$$

If $x = 0$, $a_y = v_x^2 = 1$, No matters what is the value of a_x hence, Option A is incorrect.

If $a_x = 0$ then $x = v_x t = t$

at $t = 1$; $x = 1\text{m}$

then angle made by velocity vector with x -axis





$$\tan\theta = \frac{v_y}{v_x} = x = 1 \Rightarrow \theta = 45$$

Resonance Eduventures Ltd.

Reg. Office & Corp. Office : CG Tower, A-46 & 52, IPIA, Near City Mall, Jhalawar Road, Kota (Raj.) - 324005

Ph. No.: +91-744-2777777, 2777700 | FAX No. : +91-022-39167222

To Know more : sms RESO at 56677 | Website : www.resonance.ac.in | E-mail : contact@resonance.ac.in | CIN : U80302RJ2007PLC024029

Toll Free : 1800 258 5555  7340010333  facebook.com/ResonanceEdu  twitter.com/ResonanceEdu  www.youtube.com/resowatch  blog.resonance.ac.in

SECTION 3 (Maximum Marks : 24)

- This section contains **SIX (06)** questions. The answer to each question is a **NUMERICAL VALUE**.
- For each question, enter the correct numerical value of the answer using the mouse and the on-screen virtual numeric keypad in the place designated to enter the answer. If the numerical value has more than two decimal places, **truncate/round-off** the value to **TWO** decimal places.
- Answer to each question will be evaluated according to the following marking scheme :
 Full Marks : **+4** If ONLY the correct numerical value is entered.
 Zero Marks : **0** In all other cases.

13. A spherical bubble inside water has radius R . Take the pressure inside the bubble and the water pressure to be p_0 . The bubble now gets compressed radially in an adiabatic manner so that its radius becomes $(R - a)$. For $a \ll R$ the magnitude of the work done in the process is given by $(4\pi p_0 R a^2)X$, where X is a constant and $\gamma = C_p/C_v = 41/30$. The value of X is _____.

Ans. **1 or BONUS**

Sol. $dW = P_0 dV = P_0 4\pi r^2 dr$

$\Rightarrow r = R, dr = a.$

Here answer appears $(4\pi p_0 R^2 a)$.

If we consider the expression exactly in the question, it should be a Bonus.

Considering this error as printing error,

Ans. $X = 1$ is acceptable.

14. In the balanced condition, the values of the resistances of the four arms of a Wheatstone bridge are shown in the figure below. The resistance R_3 has temperature coefficient $0.0004 \text{ } ^\circ\text{C}^{-1}$. If the temperature of R_3 is increased by $100 \text{ } ^\circ\text{C}$, the voltage developed between S and T will be _____ volt.

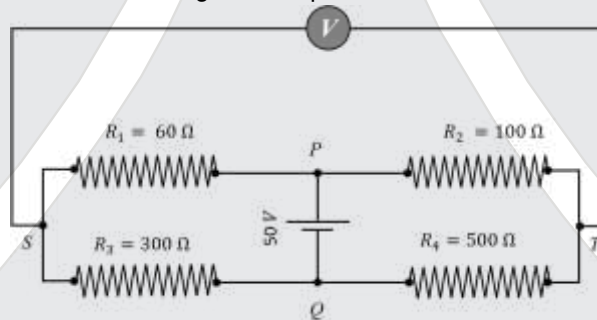

Ans. **0.27**

Sol. $R_3 = 300 (1 + \alpha \Delta T)$

$= 300 \left(1 + \frac{4}{10000} \times 100 \right) = 312$

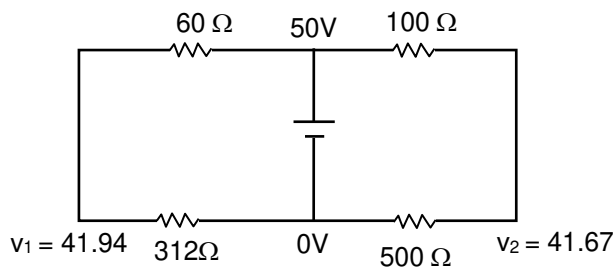

$V_1 = 41.9354 = 41.94$

$V_2 = 41.666 = 41.67$

$V_1 - V_2 = 41.94 - 41.67 = 0.27$

Resonance Eduventures Ltd.

Reg. Office & Corp. Office : CG Tower, A-46 & 52, IPIA, Near City Mall, Jhalawar Road, Kota (Raj.) - 324005

Ph. No.: +91-744-2777777, 2777700 | FAX No. : +91-022-39167222

To Know more : sms RESO at 56677 | Website : www.resonance.ac.in | E-mail : contact@resonance.ac.in | CIN : U80302RJ2007PLC024029

Toll Free : 1800 258 5555 | [facebook.com/ResonanceEdu](https://www.facebook.com/ResonanceEdu) | twitter.com/ResonanceEdu | www.youtube.com/resowatch | blog.resonance.ac.in

15. Two capacitors with capacitance values $C_1 = 2000 \pm 10$ pF and $C_2 = 3000 \pm 15$ pF are connected in series. The voltage applied across this combination is $V = 5.00 \pm 0.02$ V. The percentage error in the calculation of the energy stored in this combination of capacitors is _____.

Ans. 2.30

Sol. For the purpose of calculation of error, fundamental formula is considered

$$\frac{1}{C} = \frac{1}{C_1} + \frac{1}{C_2} \Rightarrow C = 1200 \text{ pF}$$

$$-\frac{dC}{C^2} = -\frac{dC_1}{C_1^2} - \frac{dC_2}{C_2^2}$$

$$dC = 6 \text{ pF}$$

$$\text{Equivalent capacitance} = 1200 \pm 6 \text{ (pF)}$$

$$E = \frac{1}{2} CV^2$$

$$(dE/E = dC/C + 2dv/v) \times 100$$

$$= 1.3\%$$

16. A cubical solid aluminium (bulk modulus = $-V \frac{dp}{dv} = 70$ GPa) block has an edge length of 1 m on the surface of the earth. It is kept on the floor of a 5 km deep ocean. Taking the average density of water and the acceleration due to gravity to be 10^3 kg m^{-3} and 10 ms^{-2} , respectively, the change in the edge length of the block in mm is _____.

Ans. 0.24

Sol. $B = \frac{P}{\left(-\frac{dv}{v}\right)} \quad \frac{dv}{v} = -\frac{P}{B} \Rightarrow 3 \frac{dl}{l} = \frac{-P}{B}$

$$dl = \left(\frac{-P}{B}\right) \frac{l}{3} = \frac{10^3 \frac{\text{kg}}{\text{m}^3} \times \frac{10\text{m}}{\text{s}^2} \times 5 \times 10^3}{70 \times 10^9} \times \frac{1\text{m}}{3}$$

$$dl = 0.238 \times 10^{-3}$$

$$\Rightarrow dl = 0.238 \text{ mm}$$

$$= 0.24.$$

17. The inductors of two LR circuits are placed next to each other, as shown in the figure. The values of the self-inductance of the inductors, resistances, mutual-inductance and applied voltages are specified in the given circuit. After both the switches are closed simultaneously, the total work done by the batteries against the induced EMF in the inductors by the time the currents reach their steady state values is _____ mJ.

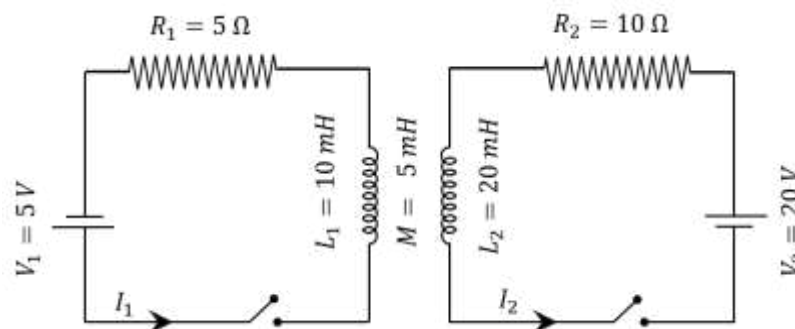

Ans. 55 or 35

Resonance Eduventures Ltd.

Reg. Office & Corp. Office : CG Tower, A-46 & 52, IPIA, Near City Mall, Jhalawar Road, Kota (Raj.) - 324005

Ph. No.: +91-744-2777777, 2777700 | FAX No. : +91-022-39167222

To Know more : sms RESO at 56677 | Website : www.resonance.ac.in | E-mail : contact@resonance.ac.in | CIN : U80302RJ2007PLC024029

Toll Free : 1800 258 5555 | [facebook.com/ResonanceEdu](https://www.facebook.com/ResonanceEdu) | twitter.com/ResonanceEdu | www.youtube.com/resowatch | blog.resonance.ac.in

Sol.

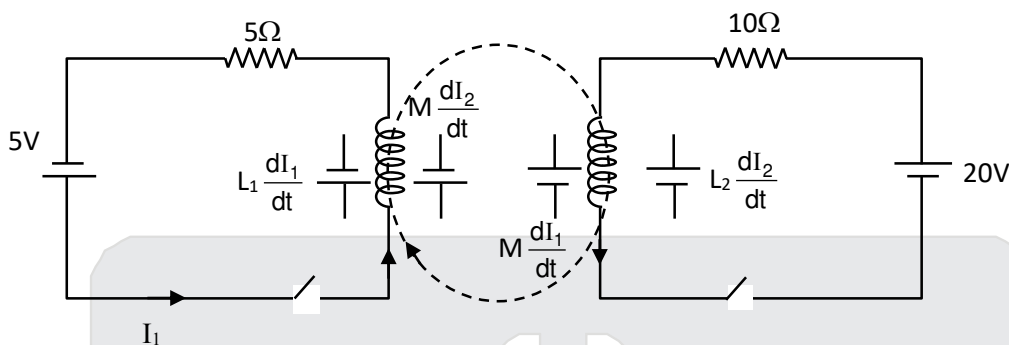

$$\varepsilon_1 = L_1 \frac{di_1}{dt} + M \frac{di_2}{dt}$$

$$dW_1 = \varepsilon_1 i_1 dt$$

$$= L_1 (di_1) i_1 + M (di_2) i_1$$

$$dW_2 = L_2 (di_2) i_2 + M (di_1) i_2$$

$$dW_1 + dW_2 = L_1 i_1 (di_1) + L_2 i_2 (di_2) + M (i_1 \cdot i_2)$$

$$W = \frac{1}{2} L_1 i_1^2 + \frac{1}{2} L_2 i_2^2 + M i_1 i_2$$

$$= 55 \text{ mJ}$$

Note : If mutual induction is taken in opposite direction then $W = 35 \text{ mJ}$

18. A container with 1 kg of water in it is kept in sunlight, which causes the water to get warmer than the surroundings. The average energy per unit time per unit area received due to the sunlight is 700 Wm^{-2} and it is absorbed by the water over an effective area of 0.05 m^2 . Assuming that the heat loss from the water to the surroundings is governed by Newton's law of cooling, the difference (in $^{\circ}\text{C}$) in the temperature of water and the surroundings after a long time will be _____. (Ignore effect of the container, and take constant for Newton's law of cooling = 0.001 s^{-1} , Heat capacity of water = $4200 \text{ J kg}^{-1} \text{ K}^{-1}$)

Ans. 8.33

Sol. $P_i = 700 \times 0.05 = 35 \text{ watts}$

$$P_i = P_r$$

$$35 = e\sigma A T_0^3 (\Delta T) \quad \dots(1)$$

$$\therefore K = \frac{4e\sigma A T_0^3}{mC} = 0.0001$$

$$4e\sigma A T_0^3 = 0.001 \times mC = 4.2$$

from equation (1)

$$\Delta T = \frac{35}{4.2} = \frac{50}{6} = \frac{25}{3} = 8.33$$

Resonance Eduventures Ltd.

Reg. Office & Corp. Office : CG Tower, A-46 & 52, IPIA, Near City Mall, Jhalawar Road, Kota (Raj.) - 324005

Ph. No.: +91-744-2777777, 2777700 | FAX No. : +91-022-39167222

To Know more : sms RESO at 56677 | Website : www.resonance.ac.in | E-mail : contact@resonance.ac.in | CIN : U80302RJ2007PLC024029

Toll Free : 1800 258 5555 | [facebook.com/ResonanceEdu](https://www.facebook.com/ResonanceEdu) | twitter.com/ResonanceEdu | www.youtube.com/resowatch | blog.resonance.ac.in

Few things remain unchanged forever...
So, is our tradition of delivering

Self-Earned & Owned Result

58.68%

Success % of Eligibility
to appearance

14717

Classroom: 11047 | Distance: 3670

STUDENTS
ELIGIBLE FOR
JEE (ADVANCED) 2020

ALL INDIA RANKS (AIRs) IN TOP-200 FROM CLASSROOM



AIR-37

AVI KUMAR
With us since Class 11th



AIR-74

SANKALP PARASHAR
With us since Class 11th



AIR-87

ACHINTYA NATH
With us since Class 11th



AIR-124

UTKARSH P. SINGH
With us since Class 10th



AIR-129

AARYAN K. GUPTA
With us since Class 9th



AIR-131

SREEMANTI DEY
With us since Class 11th

STATE TOPPER
WEST BENGAL



AIR-143

RAHUL KANOONGO
With us since Class 13th
हिन्दी माध्यम विद्यार्थी



AIR-148

DHANANJAY KEJRIWAL
With us since Class 9th



AIR-150

PRAKHAR BANSAL
With us since Class 11th



AIR-155

HARSH TRIVEDI
With us since Class 8th



AIR-161

DARSHAN RAKHEWAR
With us since Class 11th



AIR-167

JATIN K. GUPTA
With us since Class 11th



AIR-190

MIR MOHAMMAD ASIF
With us since Class 11th



AIR-198

KUSHAGRA GUPTA
With us since Class 11th

RESULT HIGHLIGHTS

7 AIRs

(AIR-53, 81, 91, 106, 113, 132, 142)
in TOP-200
Distance (DLP)

41 Students

(Classroom: 25 | Distance: 16)
with 100 %tile
in P/C/M

50 AIRs in TOP-500

(Classroom: 36 | Distance: 14)

109 AIRs in TOP-1000

(Classroom: 77 | Distance: 32)

4 AIRs

(SC: AIR-4, 8 & 10 | ST: AIR-9)

in TOP-10
Classroom