

This booklet contains 24 printed pages.

PAPER - 1 : PHYSICS, CHEMISTRY & MATHEMATICS

Test Booklet Code

E

Do not open this Test Booklet until you are asked to do so.
Read carefully the Instructions on the Back Cover of this Test Booklet.

Important Instructions :

1. Immediately fill in the particulars on this page of the Test Booklet with *only Blue / Black Ball Point Pen* provided by the Board.
2. The Answer Sheet is kept inside this Test Booklet. When you are directed to open the Test Booklet, take out the Answer Sheet and fill in the particulars carefully.
3. The test is of 3 hours duration.
4. The Test Booklet consists of 90 questions. The maximum marks are 360.
5. There are *three* parts in the question paper A, B, C consisting of **Physics, Chemistry and Mathematics** having 30 questions in each part of equal weightage. Each question is allotted (four) marks for each correct response.
6. Candidate is awarded marks as stated above in instruction No. 5 for correct response of each question. $\frac{1}{4}$ (one) mark will be deducted for indicating incorrect response of each question. No deduction from the total marks made if no response is indicated for an item in the answer sheet.
7. There is only one correct response for each question. Filling up more than one response in each question will be treated as wrong response and marks for wrong response will be deducted accordingly as per instruction 6 above.
8. For writing particulars/markings responses on *Side-1* and *Side-2* of the Answer Sheet use *only Blue/Black Ball Point Pen* provided by the Board.
9. No candidate is allowed to carry any textual material, printed or written, bits of papers, pager, mobile phone, any electronic device, etc. except the Admit Card inside the examination room/hall.
10. Rough work is to be done on the space provided for this purpose in the Test Booklet only. This space is given at the bottom of each page and in three pages (Pages 21 - 23) at the end of the booklet.
11. On completion of the test, the candidate must hand over the Answer Sheet to the Invigilator on duty in the Room/Hall. *However, the candidates are allowed to take away this Test Booklet with them.*
12. The CODE for this Booklet is **E**. Make sure that the CODE printed on *Side-2* of the Answer Sheet and also tally the serial number of the Test Booklet and Answer Sheet are the same as that on this booklet. In case of discrepancy, the candidate should immediately report the matter to the Invigilator for replacement of both the Test Booklet and the Answer Sheet.
13. **Do not fold or make any stray mark on the Answer Sheet.**

SEAL

Name of the Candidate (in Capital letters) : SUREEYA VERMA

Roll Number : in figures

2	1	9	0	0	3	1	3
---	---	---	---	---	---	---	---

: in words Two One Nine zero zero Three One Three.

Examination Centre Number :

2	1	9	0	0	2
---	---	---	---	---	---

Name of Examination Centre (in Capital letters) : TUL AVADH SCHOOL

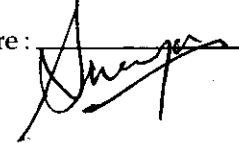
Candidate's Signature : 

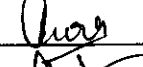
1. Invigilator's Signature : 

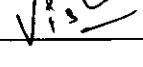
2. Invigilator's Signature : 

PART A – PHYSICS

ALL THE GRAPHS GIVEN ARE SCHEMATIC AND NOT DRAWN TO SCALE.

1. A student measures the time period of 100 oscillations of a simple pendulum four times. The data set is 90 s, 91 s, 95 s and 92 s. If the minimum division in the measuring clock is 1 s, then the reported mean time should be :

- (1) 92 ± 2 s
- (2) 92 ± 5.0 s
- (3) 92 ± 1.8 s
- (4) 92 ± 3 s

2. A particle of mass m is moving along the side of a square of side 'a', with a uniform speed v in the x - y plane as shown in the figure :

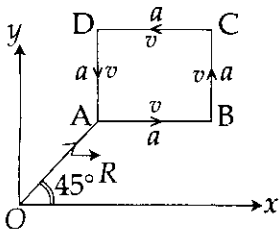

Which of the following statements is false for the angular momentum \vec{L} about the origin ?

- (1) $\vec{L} = -\frac{mv}{\sqrt{2}} R \hat{k}$ when the particle is moving from A to B.
- (2) $\vec{L} = mv \left[\frac{R}{\sqrt{2}} - a \right] \hat{k}$ when the particle is moving from C to D.
- (3) $\vec{L} = mv \left[\frac{R}{\sqrt{2}} + a \right] \hat{k}$ when the particle is moving from B to C.
- (4) $\vec{L} = \frac{mv}{\sqrt{2}} R \hat{k}$ when the particle is moving from D to A.

A point particle of mass m , moves along the uniformly rough track PQR as shown in the figure. The coefficient of friction, between the particle and the rough track equals μ . The particle is released, from rest, from the point P and it comes to rest at a point R. The energies, lost by the ball, over the parts, PQ and QR, of the track, are equal to each other, and no energy is lost when particle changes direction from PQ to QR.

The values of the coefficient of friction μ and the distance $x(=QR)$, are, respectively close to :

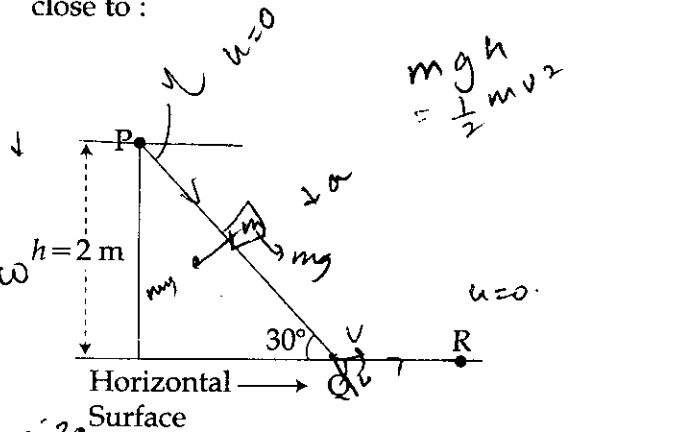

Handwritten calculations for the second question:

- $\frac{P}{h} = \sin 30$
- $\frac{2}{h} = \frac{1}{2}$
- $h = 4$
- (1) 0.2 and 6.5 m
- (2) 0.2 and 3.5 m
- $f = \mu mg \frac{\sqrt{3}}{2}$
- $v^2 = 2as = 2(a - g \sin 30) s$
- $\Rightarrow (2a - g) s$
- (3) 0.29 and 3.5 m
- $2\sqrt{(2a - g)}$
- (4) 0.29 and 6.5 m
- $40 \mu mg \frac{\sqrt{3}}{2} = \frac{40 \mu mg}{2}$

Handwritten calculation at the bottom right:

$$\mu = \frac{1}{\sqrt{3}} = \frac{1.000}{1.73} = 0.50$$

4. A person trying to lose weight by burning fat lifts a mass of 10 kg upto a height of 1 m 1000 times. Assume that the potential energy lost each time he lowers the mass is dissipated. How much fat will he use up considering the work done only when the weight is lifted up? Fat supplies 3.8×10^7 J of energy per kg which is converted to mechanical energy with a 20% efficiency rate. Take $g = 9.8 \text{ ms}^{-2}$:

- (1) 2.45×10^{-3} kg
- (2) 6.45×10^{-3} kg
- (3) 9.89×10^{-3} kg
- (4) 12.89×10^{-3} kg

5. A roller is made by joining together two cones at their vertices O. It is kept on two rails AB and CD which are placed asymmetrically (see figure), with its axis perpendicular to CD and its centre O at the centre of line joining AB and CD (see figure). It is given a light push so that it starts rolling with its centre O moving parallel to CD in the direction shown. As it moves, the roller will tend to :

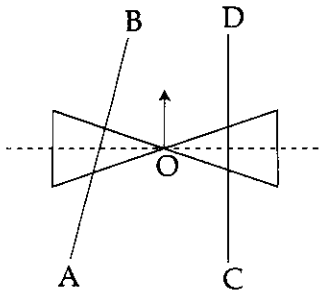

- (1) turn left.
- (2) turn right.
- (3) go straight.
- (4) turn left and right alternately.

6. A satellite is revolving in a circular orbit at a height 'h' from the earth's surface (radius of earth R ; $h \ll R$). The minimum increase in its orbital velocity required, so that the satellite could escape from the earth's gravitational field, is close to : (Neglect the effect of atmosphere.)

- (1) $\sqrt{2gR}$
- (2) \sqrt{gR}
- (3) $\sqrt{gR/2}$
- (4) $\sqrt{gR} (\sqrt{2} - 1)$

7. A pendulum clock loses 12 s a day if the temperature is 40°C and gains 4 s a day if the temperature is 20°C . The temperature at which the clock will show correct time, and the co-efficient of linear expansion (α) of the metal of the pendulum shaft are respectively :

- (1) 25°C ; $\alpha = 1.85 \times 10^{-5}/^\circ\text{C}$
- (2) 60°C ; $\alpha = 1.85 \times 10^{-4}/^\circ\text{C}$
- (3) 30°C ; $\alpha = 1.85 \times 10^{-3}/^\circ\text{C}$
- (4) 55°C ; $\alpha = 1.85 \times 10^{-2}/^\circ\text{C}$

$$\frac{\Delta X}{X} = \alpha \Delta T$$

20°

$$\begin{array}{r} 1173 \\ \times 5 \\ \hline 865 \\ 1000 \\ \hline 135 \end{array}$$

$$\begin{aligned} \text{1 day} &= 24 \text{ hrs} \\ &= 24 \times 60 \times 60 \\ &= 86400 \text{ s} \end{aligned}$$

8. An ideal gas undergoes a quasi static, reversible process in which its molar heat capacity C remains constant. If during this process the relation of pressure P and volume V is given by $PV^n = \text{constant}$, then n is given by (Here C_p and C_v are molar specific heat at constant pressure and constant volume, respectively) :

$PV^n = \text{constant}$

(1) $n = \frac{C_p}{C_v}$

(2) $n = \frac{C - C_p}{C - C_v}$

(3) $n = \frac{C_p - C}{C - C_v}$

(4) $n = \frac{C - C_v}{C - C_p}$

$C_{\text{Process}} = C_v - \frac{R}{\gamma - 1}$

9. 'n' moles of an ideal gas undergoes a process A → B as shown in the figure. The maximum temperature of the gas during the process will be :

$n = \frac{P_0 V_0}{R T_0}$

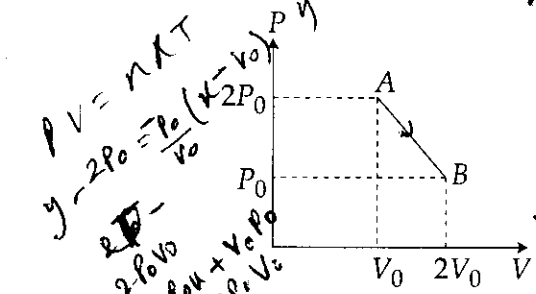

$PV = nRT$
 $y - 2P_0 = \frac{P_0}{V_0} (x - V_0)$
 $V_0 y - 2P_0 V_0 = -P_0 x + P_0 V_0$
 $V_0 y + P_0 x = 3P_0 V_0$
 $y = \frac{3P_0 V_0}{V_0} - \frac{P_0}{V_0} x$

(1) $\frac{9 P_0 V_0}{4 n R}$

(2) $\frac{3 P_0 V_0}{2 n R}$

(3) $\frac{9 P_0 V_0}{2 n R}$

(4) $\frac{9 P_0 V_0}{n R}$

$W = \int P dV$

$\frac{1}{2} \times V_0 \times P_0 + P_0 V_0$

$\neq \frac{3}{2} P_0 V_0$

$PV = nRT$

$W = nRT \ln \left(\frac{2V_0}{V_0} \right)$

$= \frac{3}{2} P_0 V_0 = \frac{3}{2} nRT$

10. A particle performs simple harmonic motion with amplitude A . Its speed is trebled at the instant that it is at a distance $\frac{2A}{3}$ from equilibrium position. The new amplitude of the motion is :

(1) $\frac{A}{3} \sqrt{41}$

(2) $3A$

(3) $A\sqrt{3}$

(4) $\frac{7A}{3}$

$y = A \sin \omega t$
 $v = \omega \sqrt{A^2 - y^2}$
 $= \omega \sqrt{A^2 (1 - \sin^2 \omega t)}$
 $= \omega A \cos \omega t$

$3v = \omega \sqrt{A^2 - y^2}$

11. A uniform string of length 20 m is suspended from a rigid support. A short wave pulse is introduced at its lowest end. It starts moving up the string. The time taken to reach the support is : (take $g = 10 \text{ ms}^{-2}$)

(1) $2\pi\sqrt{2} \text{ s}$

(2) 2 s

(3) $2\sqrt{2} \text{ s}$

(4) $\sqrt{2} \text{ s}$

\downarrow
 $P_0 (v_0 - v_1)$
 $C \omega = 0$
 $I = nRT \ln \left(\frac{v_2}{v_1} \right)$
 $nRT \ln \left(\frac{P_1}{P_2} \right)$

12. The region between two concentric spheres of radii 'a' and 'b', respectively (see figure), has volume charge density $\rho = \frac{A}{r}$, where A is a constant and r is the distance from the centre. At the centre of the spheres is a point charge Q. The value of A such that the electric field in the region between the spheres will be constant, is :

$v = \omega \sqrt{A^2 - y^2}$
 $v = A\omega$
 $3v = \omega \sqrt{A^2 - \frac{4}{9}A^2}$
 $3 = \frac{\omega \sqrt{A^2 - \frac{4}{9}A^2}}{A\omega}$
 $3A = \sqrt{A^2 - \frac{4}{9}A^2}$
 $9A^2 = A^2 - \frac{4}{9}A^2$
 $8A^2 + \frac{4}{9}A^2 = A^2$
 $\frac{81A^2 + 4A^2}{9} = A^2$
 $\frac{85A^2}{9} = \frac{Q}{2\pi a^2}$
 $\frac{85A^2}{9} = \frac{\sqrt{85}A}{3}$

(2) $\frac{Q}{2\pi(b^2 - a^2)}$

(3) $\frac{2Q}{\pi(a^2 - b^2)}$

(4) $\frac{2Q}{\pi a^2}$

13. A combination of capacitors is set up as shown in the figure. The magnitude of the electric field, due to a point charge Q (having a charge equal to the sum of the charges on the 4 μF and 9 μF capacitors), at a point distant 30 m from it, would equal :

$Ef = \frac{1}{4\pi\epsilon_0} \times \frac{Q}{(30)^2}$

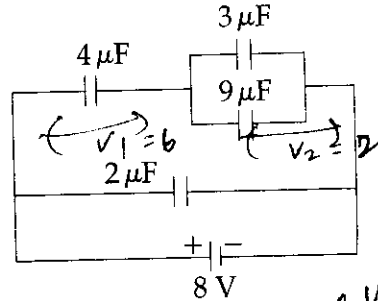

$Q = 24 + 18$
 42×10^{-6}
 $Q = CV$

- $Ef = \frac{1}{4\pi\epsilon_0} \times \frac{42 \times 10^{-6}}{900}$ (1) 240 N/C
 4 μF 12 μF (2) 360 N/C
 (3) 420 N/C
 (4) 480 N/C

$Q = CV$
 $\frac{4}{3} = \frac{V_2}{V_1}$
 $V_1 = 3V_2$
 $\frac{V_1 - 3V_2}{V_1 + V_2} = \frac{0}{8}$
 $\frac{-4V_2}{8} = -8$
 $V_2 = 2$

$Q = CV$
 $C \propto \frac{1}{V}$

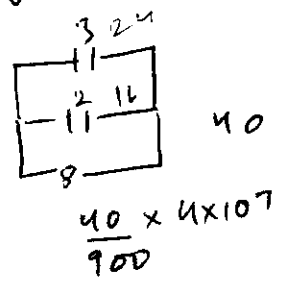

The temperature dependence of resistances of Cu and undoped Si in the temperature range 300-400 K, is best described by :

- (1) Linear increase for Cu, linear increase for Si.
- (2) Linear increase for Cu, exponential increase for Si.
- (3) Linear increase for Cu, exponential decrease for Si.
- (4) Linear decrease for Cu, linear decrease for Si.

15. Two identical wires A and B, each of length 'l', carry the same current I. Wire A is bent into a circle of radius R and wire B is bent to form a square of side 'a'. If B_A and B_B are the values of magnetic field at the centres of the circle and square respectively, then the ratio $\frac{B_A}{B_B}$ is :

- (1) $\frac{\pi^2}{8}$
- (2) $\frac{\pi^2}{16\sqrt{2}}$
- (3) $\frac{\pi^2}{16}$
- (4) $\frac{\pi^2}{8\sqrt{2}}$

16. Hysteresis loops for two magnetic materials A and B are given below :

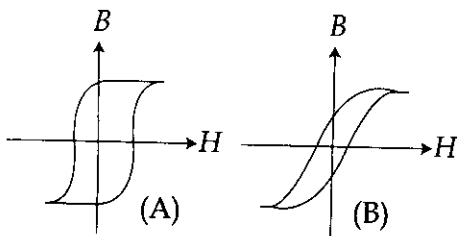

These materials are used to make magnets for electric generators, transformer core and electromagnet core. Then it is proper to use :

- (1) A for electric generators and transformers.
- (2) A for electromagnets and B for electric generators.
- (3) A for transformers and B for electric generators.
- (4) B for electromagnets and transformers.

17. An arc lamp requires a direct current of 10 A at 80 V to function. If it is connected to a 220 V (rms), 50 Hz AC supply, the series inductor needed for it to work is close to :

- (1) 80 H
- (2) 0.08 H
- (3) 0.044 H
- (4) 0.065 H



18. Arrange the following electromagnetic radiations per quantum in the order of increasing energy :

- A : Blue light
- B : Yellow light
- C : X-ray
- D : Radiowave.

(1) D, B, A, C

(2) A, B, C, D

(3) C, A, B, D

(4) B, A, D, C

$E = \frac{hc}{\lambda}$
 $\lambda >$
 V I B G Y O R
 $E <$

$\lambda >$
 B Y R
 $E >$
 $E_1 > E_2$

$\lambda >$ B > Y

E B C E Y

E A < E B

$\lambda >$ B < Y
 $E B > E Y$
 $E A > E B$

19. An observer looks at a distant tree of height 10 m with a telescope of magnifying power of 20. To the observer the tree appears :

- (1) 10 times taller.
- (2) 10 times nearer.
- (3) 20 times taller.
- (4) 20 times nearer.

20. The box of a pin hole camera, of length L , has a hole of radius a . It is assumed that when the hole is illuminated by a parallel beam of light of wavelength λ the spread of the spot (obtained on the opposite wall of the camera) is the sum of its geometrical spread and the spread due to diffraction. The spot would then have its minimum size (say b_{\min}) when :

$$(1) \quad a = \frac{\lambda^2}{L} \quad \text{and} \quad b_{\min} = \left(\frac{2\lambda^2}{L} \right)$$

$$(2) \quad a = \sqrt{\lambda L} \quad \text{and} \quad b_{\min} = \left(\frac{2\lambda^2}{L} \right)$$

$$(3) \quad a = \sqrt{\lambda L} \quad \text{and} \quad b_{\min} = \sqrt{4\lambda L}$$

$$(4) \quad a = \frac{\lambda^2}{L} \quad \text{and} \quad b_{\min} = \sqrt{4\lambda L}$$

21. Radiation of wavelength λ , is incident on a photocell. The fastest emitted electron has speed v . If the wavelength is changed to $\frac{3\lambda}{4}$, the speed of the fastest emitted electron will be :

$$(1) \quad > v \left(\frac{4}{3} \right)^{\frac{1}{2}}$$

$$(2) \quad < v \left(\frac{4}{3} \right)^{\frac{1}{2}}$$

$$(3) \quad = v \left(\frac{4}{3} \right)^{\frac{1}{2}}$$

$$(4) \quad = v \left(\frac{3}{4} \right)^{\frac{1}{2}}$$

22. Half-lives of two radioactive elements A and B are 20 minutes and 40 minutes, respectively. Initially, the samples have equal number of nuclei. After 80 minutes, the ratio of decayed numbers of A and B nuclei will be :

$$(1) \quad 1 : 16$$

$$(2) \quad 4 : 1$$

$$(3) \quad 1 : 4$$

$$(4) \quad 5 : 4$$

23. If a, b, c, d are inputs to a gate and x is its output, then, as per the following time graph, the gate is :

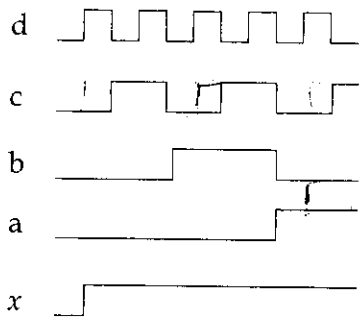

- (1) NOT
 (2) AND
 (3) OR
 (4) NAND

24. Choose the correct statement :

- (1) In amplitude modulation the amplitude of the high frequency carrier wave is made to vary in proportion to the amplitude of the audio signal.
 (2) In amplitude modulation the frequency of the high frequency carrier wave is made to vary in proportion to the amplitude of the audio signal.
 (3) In frequency modulation the amplitude of the high frequency carrier wave is made to vary in proportion to the amplitude of the audio signal.
 (4) In frequency modulation the amplitude of the high frequency carrier wave is made to vary in proportion to the frequency of the audio signal.

25. A screw gauge with a pitch of 0.5 mm and a circular scale with 50 divisions is used to measure the thickness of a thin sheet of Aluminium. Before starting the measurement, it is found that when the two jaws of the screw gauge are brought in contact, the 45th division coincides with the main scale line and that the zero of the main scale is barely visible. What is the thickness of the sheet if the main scale reading is 0.5 mm and the 25th division coincides with the main scale line ?

- (1) 0.75 mm
 (2) 0.80 mm
 (3) 0.70 mm
 (4) 0.50 mm

26. A pipe open at both ends has a fundamental frequency f in air. The pipe is dipped vertically in water so that half of it is in water. The fundamental frequency of the air column is now :

- (1) $\frac{f}{2}$
 (2) $\frac{3f}{4}$
 (3) $2f$
 (4) f

27. A galvanometer having a coil resistance of 100Ω gives a full scale deflection, when a current of 1 mA is passed through it. The value of the resistance, which can convert this galvanometer into ammeter giving a full scale deflection for a current of 10 A , is :

- (1) 0.01Ω
- (2) 2Ω
- (3) 0.1Ω
- (4) 3Ω

28. In an experiment for determination of refractive index of glass of a prism by $i - \delta$ plot, it was found that a ray incident at angle 35° , suffers a deviation of 40° and that it emerges at angle 79° . In that case which of the following is closest to the maximum possible value of the refractive index ?

- (1) 1.5
- (2) 1.6
- (3) 1.7
- (4) 1.8

29. Identify the semiconductor devices whose characteristics are given below, in the order (a), (b), (c), (d) :

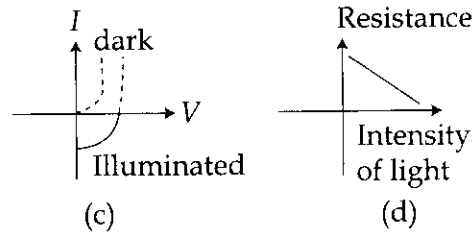
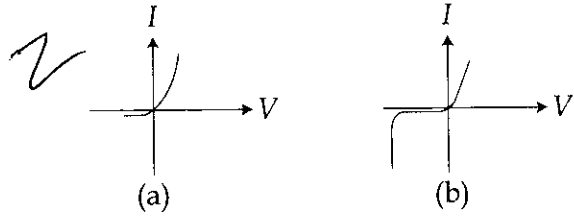

- (1) Simple diode, Zener diode, Solar cell, Light dependent resistance
- (2) Zener diode, Simple diode, Light dependent resistance, Solar cell
- (3) Solar cell, Light dependent resistance, Zener diode, Simple diode
- (4) Zener diode, Solar cell, Simple diode, Light dependent resistance

30. For a common emitter configuration, if α and β have their usual meanings, the **incorrect** relationship between α and β is :

- (1) $\frac{1}{\alpha} = \frac{1}{\beta} + 1$
- (2) $\alpha = \frac{\beta}{1 - \beta}$
- (3) $\alpha = \frac{\beta}{1 + \beta}$
- (4) $\alpha = \frac{\beta^2}{1 + \beta^2}$

PART B - CHEMISTRY

31. At 300 K and 1 atm, 15 mL of a gaseous hydrocarbon requires 375 mL air containing 20% O₂ by volume for complete combustion. After combustion the gases occupy 330 mL. Assuming that the water formed is in liquid form and the volumes were measured at the same temperature and pressure, the formula of the hydrocarbon is :

- (1) C₃H₆
- (2) C₃H₈
- (3) C₄H₈
- (4) C₄H₁₀

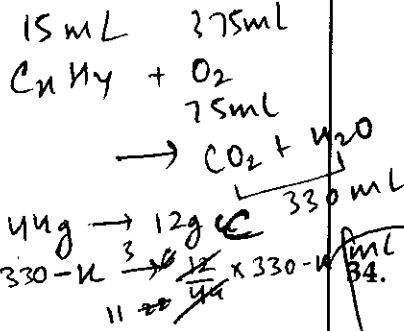

$O_2 = 75 \text{ mL}$
 $\frac{3}{4} (330 - x) + \frac{x}{4} = 15 \text{ mL}$
 $990 - 3x = 60$

32. Two closed bulbs of equal volume (V) containing an ideal gas initially at pressure p_i and temperature T_1 are connected through a narrow tube of negligible volume as shown in the figure below. The temperature of one of the bulbs is then raised to T_2 . The final pressure p_f is :

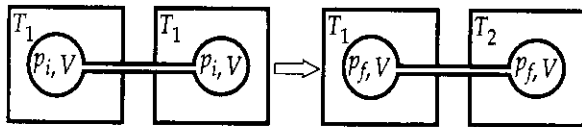

- $p_i V = nRT_1$
 $p_f \times V = nRT_1$
 $p_f \times V = nRT_2$
- (1) $p_i \left(\frac{T_1 T_2}{T_1 + T_2} \right)$
 - (2) $2p_i \left(\frac{T_1}{T_1 + T_2} \right)$
 - (3) $2p_i \left(\frac{T_2}{T_1 + T_2} \right)$
 - (4) $2p_i \left(\frac{T_1 T_2}{T_1 + T_2} \right)$

$\frac{p_i V}{nR} = D$

33. A stream of electrons from a heated filament was passed between two charged plates kept at a potential difference V esu. If e and m are charge and mass of an electron, respectively, then the value of h/λ (where λ is wavelength associated with electron wave) is given by :

- (1) meV
- (2) $2meV$
- (3) \sqrt{meV}
- (4) $\sqrt{2meV}$

$E = \frac{h\nu}{\lambda} = \frac{hc}{\lambda}$
 $\lambda = \frac{h}{m\nu}$
 $\lambda = \frac{h}{m\sqrt{2meV}}$

34. The species in which the N atom is in a state of sp hybridization is :

- (1) NO₂⁺
- (2) NO₂⁻
- (3) NO₃⁻
- (4) NO₂

$N = 7$
 $1s^2 2s^2 2p^3$

35. The heats of combustion of carbon and carbon monoxide are -393.5 and $-283.5 \text{ kJ mol}^{-1}$, respectively. The heat of formation (in kJ) of carbon monoxide per mole is :

- (1) 110.5
- (2) 676.5
- (3) -676.5
- (4) -110.5

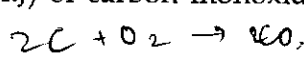

$p_f \Rightarrow 2V \times nR (T_2 - T_1)$
 $2p_f V = nR (T_2 - T_1)$
 $nRT_2 - nR \frac{p_i V}{nR}$

$$\frac{178.180}{162} = \frac{18}{126} \times \frac{7}{5}$$

$$\frac{9.9}{10.0} = \frac{0.1}{10.0}$$

$$\frac{178.2}{178.0} = \frac{9.9}{10.0}$$

18 g glucose (C₆H₁₂O₆) is added to 178.2 g water. The vapor pressure of water (in torr) for this aqueous solution is:

- (1) 7.6
- (2) 76.0
- (3) 752.4
- (4) 759.0

$$k_B = \frac{0.1}{0.1+9.9} = 0.01$$

$$\frac{p^0 - p_s}{p^0} = k_B = 0.01$$

$$1 - 0.01 = \frac{p_s}{p^0} = 0.99$$

$$p_s = 0.99 \times 178.0 = 176.22$$

$$\frac{178.2}{178.0} = \frac{9.9}{10.0}$$

37. The equilibrium constant at 298 K for a reaction A + B ⇌ C + D is 100. If the initial concentration of all the four species were 1 M each, then equilibrium concentration of D (in mol L⁻¹) will be:

- (1) 0.182
- (2) 0.818
- (3) 1.818
- (4) 1.182

$$100 = \frac{(1-x)^2}{(1+x)^2}$$

$$10(1-x) = 1+x$$

$$10 - 10x = 1+x$$

$$9 = 11x$$

$$x = \frac{9}{11} = 0.818$$

38. Galvanization is applying a coating of:

- (1) Pb
- (2) Cr
- (3) Cu
- (4) Zn



$$k = \frac{0.693}{2.5}$$

$$50 - \frac{1}{4}$$

$$k = \frac{1}{2} \times \frac{1}{2.5}$$

$$\frac{50}{k} = 2.5$$

39. Decomposition of H₂O₂ follows a first order reaction. In fifty minutes the concentration of H₂O₂ decreases from 0.5 to 0.125 M in one such decomposition. When the concentration of H₂O₂ reaches 0.05 M, the rate of formation of O₂ will be:

- (1) 6.93 × 10⁻² mol min⁻¹
- (2) 6.93 × 10⁻⁴ mol min⁻¹
- (3) 2.66 L min⁻¹ at STP
- (4) 1.34 × 10⁻² mol min⁻¹

$$\frac{p_0 - p_s}{p_0} = \frac{0.5 - 0.125}{0.5} = 0.75$$

$$k_A = \frac{0.1}{10} = 0.01$$

$$0.1 \rightarrow k$$

$$9.9 \rightarrow w$$

$$k_w = \frac{9.9}{10} = 0.99$$

SPACE FOR ROUGH WORK

$$p_s = p^0 \times 0.99$$

$$0.01 \times 10 = 0.1$$

$$\frac{1 - 0.99}{0.99} = \frac{p_A - p^0 k}{p_T}$$

$$p_T = p^0 k_A + p^0 k_B$$

40. For a linear plot of log (x/m) versus log p in a Freundlich adsorption isotherm, which of the following statements is correct? (k and n are constants)

- (1) Both k and 1/n appear in the slope term.
- (2) 1/n appears as the intercept.
- (3) Only 1/n appears as the slope.
- (4) log (1/n) appears as the intercept.

$$\frac{x}{m} = k p^{1/n}$$

$$\log \frac{x}{m} = \log k + \frac{1}{n} \log p$$

41. Which of the following atoms has the highest first ionization energy?

- (1) Rb
- (2) Na
- (3) K
- (4) Sc

$$y = \frac{1}{n} \log k$$

42. Which one of the following ores is best concentrated by froth floatation method?

- (1) Magnetite Fe₂O₃
- (2) Siderite
- (3) Galena PbS
- (4) Malachite

43. Which one of the following statements about water is FALSE?

- (1) Water is oxidized to oxygen during photosynthesis.
- (2) Water can act both as an acid and as a base.
- (3) There is extensive intramolecular hydrogen bonding in the condensed phase.
- (4) Ice formed by heavy water sinks in normal water.

$$D_2O \quad m \uparrow \quad d \uparrow$$

$$\text{partial } p = p^0 k$$

44. The main oxides formed on combustion of Li, Na and K in excess of air are, respectively :

- (1) Li_2O , Na_2O and KO_2
- (2) LiO_2 , Na_2O_2 and K_2O
- (3) Li_2O_2 , Na_2O_2 and KO_2
- (4) Li_2O , Na_2O_2 and KO_2

45. The reaction of zinc with dilute and concentrated nitric acid, respectively, produces :

- (1) N_2O and NO_2
- (2) NO_2 and NO
- (3) NO and N_2O
- (4) NO_2 and N_2O

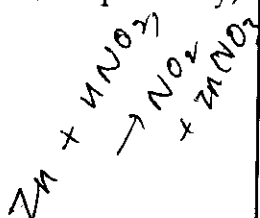

46. The pair in which phosphorous atoms have a formal oxidation state of +3 is :

- (1) Orthophosphorous and pyrophosphorous acids
- (2) Pyrophosphorous and hypophosphoric acids
- (3) Orthophosphorous and hypophosphoric acids
- (4) Pyrophosphorous and pyrophosphoric acids



47. Which of the following compounds is metallic and ferromagnetic ?

- (1) TiO_2
- (2) CrO_2
- (3) VO_2
- (4) MnO_2

48. The pair having the same magnetic moment is :

[At. No.: Cr = 24, Mn = 25, Fe = 26, Co = 27]

- (1) $[\text{Cr}(\text{H}_2\text{O})_6]^{2+}$ and $[\text{CoCl}_4]^{2-}$
- (2) $[\text{Cr}(\text{H}_2\text{O})_6]^{2+}$ and $[\text{Fe}(\text{H}_2\text{O})_6]^{2+}$
- (3) $[\text{Mn}(\text{H}_2\text{O})_6]^{2+}$ and $[\text{Cr}(\text{H}_2\text{O})_6]^{2+}$
- (4) $[\text{CoCl}_4]^{2-}$ and $[\text{Fe}(\text{H}_2\text{O})_6]^{2+}$

49. Which one of the following complexes shows optical isomerism ?

- (1) $[\text{Co}(\text{NH}_3)_3\text{Cl}_3]$
 - (2) *cis* $[\text{Co}(\text{en})_2\text{Cl}_2]\text{Cl}$
 - (3) *trans* $[\text{Co}(\text{en})_2\text{Cl}_2]\text{Cl}$
 - (4) $[\text{Co}(\text{NH}_3)_4\text{Cl}_2]\text{Cl}$
- (en = ethylenediamine)

50. The concentration of fluoride, lead, nitrate and iron in a water sample from an underground lake was found to be 1000 ppb, 40 ppb, 100 ppm and 0.2 ppm, respectively. This water is unsuitable for drinking due to high concentration of :

- (1) Fluoride
- (2) Lead
- (3) Nitrate
- (4) Iron

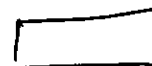

51. The distillation technique most suited for separating glycerol from spent-lye in the soap industry is :

- (1) Simple distillation
- (2) Fractional distillation
- (3) Steam distillation
- (4) Distillation under reduced pressure

52. The product of the reaction given below is :

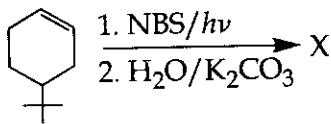

- (1)
- (2)
- (3)
- (4)

53. The absolute configuration of

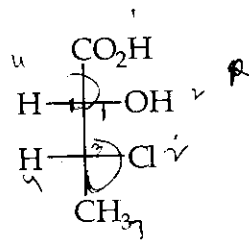

is :

- (1) (2R, 3S)
- (2) (2S, 3R)
- (3) (2S, 3S)
- (4) (2R, 3R)

54. 2-chloro-2-methylpentane on reaction with sodium methoxide in methanol yields :

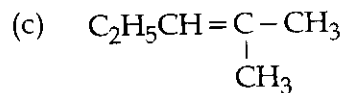
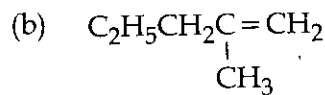
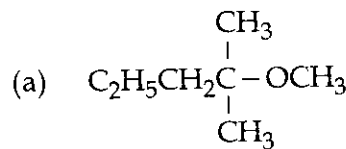

- (1) All of these
- (2) (a) and (c)
- (3) (c) only
- (4) (a) and (b)

E/Page 13

SPACE FOR ROUGH WORK

$$\text{Rate} = k [\text{H}_2\text{O}_2]$$

$$\log_{10} 4 = k$$

$$10^k = 4$$

$$k = \frac{2.303 \log \frac{0.500}{0.125}}{50} = \frac{2.303 \log 4}{50}$$

$$k = \frac{2.303 \times 2 \log 2}{50} = \frac{4.606 \log 2}{50}$$

$$k = \frac{6.93}{500} = 0.0138$$

$$\frac{2.303 \times 0.605 \log 2}{25} = \frac{2.303 \log 2 \times 0.605}{25} \times 2$$

$$\text{Rate} = -\frac{1}{2} \frac{d[\text{H}_2\text{O}_2]}{dt}$$

$$= 2 \frac{d[\text{O}_2]}{dt}$$

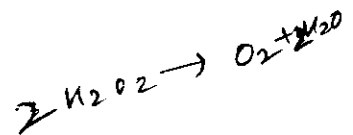

$$\frac{d[\text{O}_2]}{dt} = \frac{1}{2} \frac{d[\text{H}_2\text{O}_2]}{dt}$$

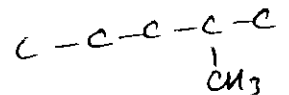

NaOCH₃ CH₃OH

COOH

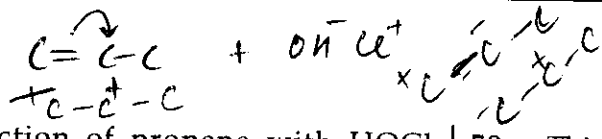

55. The reaction of propene with HOCl ($Cl_2 + H_2O$) proceeds through the intermediate :

- (1) $CH_3-CH^+-CH_2-OH$ \times
 (2) $CH_3-CH^+-CH_2-Cl$ \times
 (3) $CH_3-CH(OH)-CH_2^+$ \times
 (4) $CH_3-CHCl-CH_2^+$

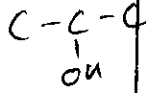

56. In the Hofmann bromamide degradation reaction, the number of moles of NaOH and Br_2 used per mole of amine produced are :

- (1) One mole of NaOH and one mole of Br_2 .
 (2) Four moles of NaOH and two moles of Br_2 .
 (3) Two moles of NaOH and two moles of Br_2 .
 (4) Four moles of NaOH and one mole of Br_2 .

57. Which of the following statements about low density polythene is FALSE ?

- (1) Its synthesis requires high pressure.
 (2) It is a poor conductor of electricity.
 (3) Its synthesis requires dioxygen or a peroxide initiator as a catalyst.
 (4) It is used in the manufacture of buckets, dust-bins etc.

58. Thiol group is present in :

- (1) Cytosine
 (2) Cystine
 (3) Cysteine
 (4) Methionine

59. Which of the following is an anionic detergent ?

- (1) Sodium stearate
 (2) Sodium lauryl sulphate
 (3) Cetyltrimethyl ammonium bromide
 (4) Glyceryl oleate

60. The hottest region of Bunsen flame shown in the figure below is :

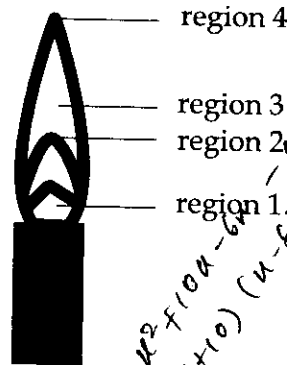

- (1) region 1
 (2) region 2
 (3) region 3
 (4) region 4

$n^2 + 10n - 60$
 $(n+10)(n-6)$
 $10^x = 1$
 $n^2 - 5n + 5 = 1$
 $n^2 - 5n - 4 = 0$
 $(n-8)(n+3)$

240
16

SPACE FOR ROUGH WORK
 $n^2 + 10n - 60$
 $n^2 - 5n + 5 = 1$
 $n^2 - 5n - 4 = 0$
 $(n-8)(n+3)$
 $n = 8$
 $16 - 20 + 5 = 1$
 $36 - 30 + 5 = 1$

$n^2 + 10n - 60$
 $n^2 - 5n + 5 = 1$
 $n = 8$
 $16 - 20 + 5 = 1$
 $36 - 30 + 5 = 1$

PART C – MATHEMATICS

61. If $f(x) + 2f\left(\frac{1}{x}\right) = 3x$, $x \neq 0$, and $S = \{x \in \mathbb{R} : f(x) = f(-x)\}$; then S :
- (1) is an empty set.
 - (2) contains exactly one element.
 - (3) contains exactly two elements.
 - (4) contains more than two elements.

62. A value of θ for which $\frac{2 + 3i \sin \theta}{1 - 2i \sin \theta}$ is purely imaginary, is :

- (1) $\frac{\pi}{3}$
- (2) $\frac{\pi}{6}$
- (3) $\sin^{-1}\left(\frac{\sqrt{3}}{4}\right)$
- ✓ (4) $\sin^{-1}\left(\frac{1}{\sqrt{3}}\right)$

$z + \bar{z} = 0$

$$\frac{2 + 3i \sin \theta}{1 - 2i \sin \theta} + \frac{2 - 3i \sin \theta}{1 + 2i \sin \theta} = 0$$

$$\frac{2 + \frac{3i}{\sqrt{3}}}{1 - \frac{2i}{\sqrt{3}}}$$

63. The sum of all real values of x satisfying the equation

$$(x^2 - 5x + 5)^{x^2 + 4x - 60} = 1 \text{ is:}$$

- (1) 3
- ✓ (2) -4
- (3) 6
- (4) 5

$$\frac{2\sqrt{3} + 3i}{\sqrt{3} - 2i} + 3i(\sqrt{3} + 2i)$$

$$\frac{2\sqrt{3}(\sqrt{3} + 2i) + 3i(\sqrt{3} + 2i)}{3 + 4}$$

64. If $A = \begin{bmatrix} 5a & -b \\ 3 & 2 \end{bmatrix}$ and $A \text{ adj } A = A A^T$, then $5a + b$ is equal to :

- (1) -1
- (2) 5
- (3) 4
- (4) 13

$2 - 3$
 $+b \quad 5a \quad \text{adj} \begin{bmatrix} 2 & -3 \\ b & 5a \end{bmatrix}$
 $\begin{bmatrix} 5a & -b \\ 3 & 2 \end{bmatrix} \begin{bmatrix} 2 & -3 \\ b & 5a \end{bmatrix}$
 $10a - b^2 \quad -15a - 5ab$
 $6 + 2b \quad -9 + 10a$

65. The system of linear equations

$$\begin{aligned} x + \lambda y - z &= 0 \\ \lambda x - y - z &= 0 \\ x + y - \lambda z &= 0 \end{aligned}$$

$$\begin{bmatrix} 5a & -b \\ 3 & 2 \end{bmatrix} \begin{bmatrix} 5a & 3 \\ -b & 2 \end{bmatrix}$$

$$\begin{aligned} 25a^2 + b^2 & 15a - 2b \\ 15a - 2b & 9 + 4 \end{aligned}$$

has a non-trivial solution for :

- (1) infinitely many values of λ .
- (2) exactly one value of λ .
- (3) exactly two values of λ .
- (4) exactly three values of λ .

$$10a - b^2 = 25a^2 + b^2$$

66. If all the words (with or without meaning) having five letters, formed using the letters of the word SMALL and arranged as in a dictionary; then the position of the word SMALL is :

- (1) 46th
- (2) 59th
- (3) 52nd
- (4) 58th

$$-15a - 5ab = 15a - 2b$$

$$6 + 2b = 3$$

$$6 + 2b = 15a - 2b$$

$$\begin{aligned} 1 + 6 - 10 \\ -10 + 7 \\ = -3 \end{aligned}$$

$$\frac{6 + 4\sqrt{3}i + 3\sqrt{3}i}{-6}$$

$$b = \frac{5}{4}$$

$$\frac{13}{+9} = \frac{22}{22}$$

$$4b = 5$$

$$\begin{aligned} -9 + 10a &= 13 \\ 10a &= 22 \\ a &= \frac{22}{10} \end{aligned}$$

$$6 + 4b = 15 \times \frac{22}{10}$$

67. If the number of terms in the expansion of $\left(1 - \frac{2}{x} + \frac{4}{x^2}\right)^n$, $x \neq 0$, is 28, then the sum of the coefficients of all the terms in this expansion, is :

- (1) 64
- (2) 2187
- (3) 243
- (4) 729

68. If the 2nd, 5th and 9th terms of a non-constant A.P. are in G.P., then the common ratio of this G.P. is :

- (1) $\frac{8}{5}$
- (2) $\frac{4}{3}$
- (3) 1
- (4) $\frac{7}{4}$

$a + (n-1)d$

69. If the sum of the first ten terms of the series $\left(1\frac{3}{5}\right)^2 + \left(2\frac{2}{5}\right)^2 + \left(3\frac{1}{5}\right)^2 + 4^2 + \left(4\frac{4}{5}\right)^2 + \dots$, is $\frac{16}{5}m$, then m is equal to:

- (1) 102
- (2) 101
- (3) 100
- (4) 99

$\frac{9}{25} + \frac{16}{25} + \frac{9}{25} + 16$

70. Let $p = \lim_{x \rightarrow 0^+} (1 + \tan^2 \sqrt{x})^{\frac{1}{2x}}$ then $\log p$ is equal to :

- (1) 2
- (2) 1
- (3) $\frac{1}{2}$
- (4) $\frac{1}{4}$

71. For $x \in \mathbb{R}$, $f(x) = |\log 2 - \sin x|$ and $g(x) = f(f(x))$, then :

- (1) g is not differentiable at $x=0$
- (2) $g'(0) = \cos(\log 2)$
- (3) $g'(0) = -\cos(\log 2)$
- (4) g is differentiable at $x=0$ and $g'(0) = -\sin(\log 2)$

72. Consider

$$f(x) = \tan^{-1} \left(\sqrt{\frac{1 + \sin x}{1 - \sin x}} \right), x \in \left(0, \frac{\pi}{2}\right).$$

A normal to $y=f(x)$ at $x = \frac{\pi}{6}$ also passes through the point :

- (1) (0, 0)
- (2) $\left(0, \frac{2\pi}{3}\right)$
- (3) $\left(\frac{\pi}{6}, 0\right)$
- (4) $\left(\frac{\pi}{4}, 0\right)$

$\frac{1}{2} \left[k^{10} \times (k^5 + k^3 + 1)^2 \right]$
 $- 2 \sqrt{(4k^5 + 3k^2)} k^{10}$
 $\frac{9k^9}{(k^5 + k^3 + 1)^2}$

24

$2(4k^{15} + 3k^{12} + 9k^9(k^5 + k^3 + 1))$

73. A wire of length 2 units is cut into two parts which are bent respectively to form a square of side = x units and a circle of radius = r units. If the sum of the areas of the square and the circle so formed is minimum, then :

- (1) $2x = (\pi + 4)r$
- (2) $(4 - \pi)x = \pi r$
- (3) $x = 2r$
- (4) $2x = r$

74. The integral $\int \frac{2x^{12} + 5x^9}{(x^5 + x^3 + 1)^3} dx$ is equal to :

- (1) $\frac{-x^5}{(x^5 + x^3 + 1)^2} + C$
- (2) $\frac{x^{10}}{2(x^5 + x^3 + 1)^2} + C$
- (3) $\frac{x^5}{2(x^5 + x^3 + 1)^2} + C$
- (4) $\frac{-x^{10}}{2(x^5 + x^3 + 1)^2} + C$

where C is an arbitrary constant.

75. $\lim_{n \rightarrow \infty} \left(\frac{(n+1)(n+2)\dots 3n}{n^{2n}} \right)^{1/n}$ is equal to :

- (1) $\frac{18}{e^4}$
- (2) $\frac{27}{e^2}$
- (3) $\frac{9}{e^2}$
- (4) $3 \log 3 - 2$

$\frac{1}{n} \log ()$
 $\frac{n^{2n}}{(n+1)(n+2)\dots 3n}$

$-\frac{1}{2} \left[\frac{n^{10} (n^4 + 3n^2)}{()^3} - \frac{10n^9}{()^2} \right]$

76. The area (in sq. units) of the region $\{(x, y) : y^2 \geq 2x \text{ and } x^2 + y^2 \leq 4x, x \geq 0, y \geq 0\}$ is :

- (1) $\pi - \frac{4}{3}$
- (2) $\pi - \frac{8}{3}$
- (3) $\pi - \frac{4\sqrt{2}}{3}$
- (4) $\frac{\pi}{2} - \frac{2\sqrt{2}}{3}$

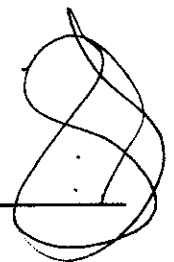
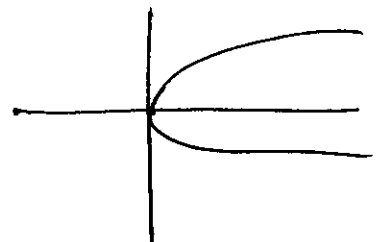

$\frac{1}{2} \left[\frac{-2(5n^4 + 3n^2)n^5}{()^3} + \frac{1}{()^2} \frac{5n^4}{5n^4(5n^3 + 1)} \right]$
 $5n^9 + 5n^7 + 5n^4$

77. If a curve $y=f(x)$ passes through the point $(1, -1)$ and satisfies the differential equation, $y(1+xy) dx = x dy$, then $f\left(-\frac{1}{2}\right)$ is equal to:

- (1) $-\frac{2}{5}$
- (2) $-\frac{4}{5}$
- (3) $\frac{2}{5}$
- (4) $\frac{4}{5}$

$y(1+xy) dx = x dy$
 $\frac{y}{x} (1+xy) = \frac{dy}{dx}$
 $(2+3)^2 + (5)^2 = 25+25 = \sqrt{50}$
 $50+25 = (5)^2 \Rightarrow 25+25$

78. Two sides of a rhombus are along the lines, $x-y+1=0$ and $7x-y-5=0$. If its diagonals intersect at $(-1, -2)$, then which one of the following is a vertex of this rhombus?

- (1) $(-3, -9)$
- (2) $(-3, -8)$
- (3) $\left(\frac{1}{3}, -\frac{8}{3}\right)$
- (4) $\left(-\frac{10}{3}, -\frac{7}{3}\right)$

$x-y+1=0$
 $7x-y-5=0$
 $-6x+6=6$
 $x=-1$

$16+k^2 - 8k = \frac{8k}{x} + 12k$
 $\frac{16+k^2 - 8k}{(4-k)^2 + (4-k)^2} = k+6$

79. The centres of those circles which touch the circle, $x^2+y^2-8x-8y-4=0$, externally and also touch the x-axis, lie on:

- (1) a circle.
- (2) an ellipse which is not a circle.
- (3) a hyperbola.
- (4) a parabola.



80. If one of the diameters of the circle, given by the equation, $x^2+y^2-4x+6y-12=0$, is a chord of a circle S, whose centre is at $(-3, 2)$, then the radius of S is:

- (1) $5\sqrt{2}$
- (2) $5\sqrt{3}$
- (3) 5
- (4) 10

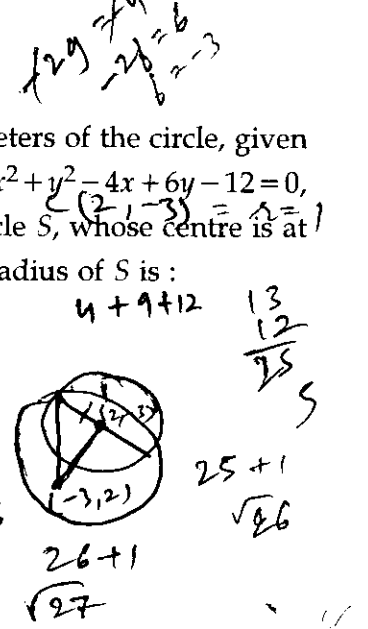

81. Let P be the point on the parabola, $y^2=8x$ which is at a minimum distance from the centre C of the circle, $x^2+(y+6)^2=1$. Then the equation of the circle, passing through C and having its centre at P is:

- (1) $x^2+y^2-4x+8y+12=0$
 $0+36-18+12$
- (2) $x^2+y^2-x+4y-12=0$
 $0+36-24-12$
- (3) $x^2+y^2-\frac{x}{4}+2y-24=0$
- (4) $x^2+y^2-4x+9y+18=0$
 $36-54+18$

82. The eccentricity of the hyperbola whose length of the latus rectum is equal to 8 and the length of its conjugate axis is equal to half of the distance between its foci, is:

- (1) $\frac{4}{3}$
- (2) $\frac{4}{\sqrt{3}}$
- (3) $\frac{2}{\sqrt{3}}$
- (4) $\sqrt{3}$

$\frac{2b^2}{a} = 8$
 $b^2 = 4a$
 $2b = \frac{1}{2} \times 2ae$
 $2b = ae$
 $4b^2 = a^2 e^2$
 $16a = a^2 e^2$
 $16 = a e^2$

$1 \times \frac{1}{3} = \frac{2}{\sqrt{3}}$
 $e = \sqrt{1 + \left(\frac{b}{a}\right)^2}$
 $e^2 = \frac{a^2 + b^2}{a^2}$
 $4b^2 = a^2 + b^2$
 $3b^2 = a^2$
 $\frac{(2ae)^2}{\left(\frac{b}{a}\right)^2} = \frac{1}{3}$

83. The distance of the point $(1, -5, 9)$ from the plane $x - y + z = 5$ measured along the line $x = y = z$ is :

- (1) $3\sqrt{10}$
- (2) $10\sqrt{3}$
- (3) $\frac{10}{\sqrt{3}}$
- (4) $\frac{20}{3}$

Handwritten work for Q83:

$$\frac{2+3+a+1}{4}$$

$$\frac{16+a}{4}$$

$$\left(\frac{-8-a}{4}\right)^2$$

$$\left(\frac{2-16+a}{4}\right)^2$$

$$= \left(\frac{-8-a}{4}\right)^2 + \left(\frac{8+a}{4}\right)^2$$

84. If the line, $\frac{x-3}{2} = \frac{y+2}{-1} = \frac{z+4}{3}$ lies in the plane, $lx + my - z = 9$, then $l^2 + m^2$ is equal to :

- (1) 26
- (2) 18
- (3) 5
- (4) 2

Handwritten work for Q84:

$$\frac{3-16+a}{4}$$

$$\frac{12-16-a}{4}$$

$$\left(\frac{-4-a}{4}\right)^2$$

85. Let \vec{a} , \vec{b} and \vec{c} be three unit vectors such that $\vec{a} \times (\vec{b} \times \vec{c}) = \frac{\sqrt{3}}{2} (\vec{b} + \vec{c})$. If \vec{b} is not parallel to \vec{c} , then the angle between \vec{a} and \vec{b} is :

- (1) $\frac{3\pi}{4}$
- (2) $\frac{\pi}{2}$
- (3) $\frac{2\pi}{3}$
- (4) $\frac{5\pi}{6}$

Handwritten work for Q85:

$$+ a - \frac{16+a}{4}$$

$$4a - 16 - a$$

$$\left(\frac{3a-16}{4}\right)^2$$

$$11 - \frac{16+a}{4}$$

$$44 - 16 - a$$

86. If the standard deviation of the numbers 2, 3, a and 11 is 3.5, then which of the following is true ?

- (1) $3a^2 - 26a + 55 = 0$
- (2) $3a^2 - 32a + 84 = 0$
- (3) $3a^2 - 34a + 91 = 0$
- (4) $3a^2 - 23a + 44 = 0$

Handwritten work for Q86:

$$\sigma = \sqrt{\frac{\sum (k_i - \bar{k})^2}{n}}$$

$$3.5 \times 3.5 \times 4 = 49$$

$$= 100 - 14 \times 3.5$$

$$= 196 \times 4$$

$$= 784$$

87. Let two fair six-faced dice A and B be thrown simultaneously. If E_1 is the event that die A shows up four, E_2 is the event that die B shows up two and E_3 is the event that the sum of numbers on both dice is odd, then which of the following statements is NOT true ?

- (1) E_1 and E_2 are independent.
- (2) E_2 and E_3 are independent.
- (3) E_1 and E_3 are independent.
- (4) E_1, E_2 and E_3 are independent.

88. If $0 \leq x < 2\pi$, then the number of real values of x , which satisfy the equation $\cos x + \cos 2x + \cos 3x + \cos 4x = 0$, is :

- (1) 3
- (2) 5
- (3) 7
- (4) 9

Handwritten work for Q88:

$$3.5 \times 4 = 14.0$$

$$14 \times 14 = 196$$

$$3 \times 7 = 21$$

$$196 - 21 = 175$$

Handwritten notes:

$$\frac{3 \times 4}{28}$$

Handwritten notes:

$$\left(\frac{28-a}{4}\right)^2$$

Handwritten notes:

$$14 \times 14 = 196$$

$$3 \times 7 = 21$$

$$196 - 21 = 175$$

89. A man is walking towards a vertical pillar in a straight path, at a uniform speed. At a certain point A on the path, he observes that the angle of elevation of the top of the pillar is 30° . After walking for 10 minutes from A in the same direction, at a point B, he observes that the angle of elevation of the top of the pillar is 60° . Then the time taken (in minutes) by him, from B to reach the pillar, is :

- (1) 6
- (2) 10
- (3) 20
- (4) 5

~~(3) 20~~
~~(4) 5~~

90. The Boolean Expression $(p \wedge \sim q) \vee q \vee (\sim p \wedge q)$ is equivalent to :

- (1) $\sim p \wedge q$
- (2) $p \wedge q$
- (3) $p \vee q$
- (4) $p \vee \sim q$

F M
P

P V M

- o o o -

SPACE FOR ROUGH WORK

M	$\sim P$	P	Q	$\sim Q$	F	P	M	
0	1	0	0	1	0	0	0	0
1	1	0	1	0	0	1	1	1
0	0	1	0	1	1	1	0	1
0	0	1	1	0	0	1	0	1

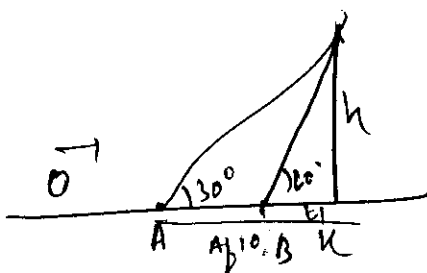

$$\tan 30 = \frac{h}{x}$$

$$x = \frac{h}{\tan 30} = \frac{h}{\frac{1}{\sqrt{3}}} = \sqrt{3}h$$

$$AB = u \times 10$$

$$\sqrt{3}h - 10u = \frac{h}{\sqrt{3}}$$

$$\sqrt{3} = \frac{h}{\sqrt{3}h - 10u}$$

$$\frac{1}{\sqrt{3}} = \frac{1}{\sqrt{3}} + \frac{1}{\sqrt{3}}$$

$$3h - 10\sqrt{3}u = \frac{h}{\sqrt{3}}$$

$$2h = \frac{h}{\sqrt{3}} + 10\sqrt{3}u$$

$$u = \frac{h}{5\sqrt{3}}$$

Read the following instructions carefully :

1. The candidates should fill in the required particulars on the Test Booklet and Answer Sheet (*Side-1*) with **Blue/Black Ball Point Pen**.
2. For writing/marking particulars on *Side-2* of the Answer Sheet, use **Blue/Black Ball Point Pen only**.
3. The candidates should not write their Roll Numbers anywhere else (except in the specified space) on the Test Booklet/ Answer Sheet.
4. Out of the four options given for each question, only one option is the correct answer.
5. For each **incorrect response**, **one-fourth** ($\frac{1}{4}$) of the total marks allotted to the question would be deducted from the total score. **No deduction** from the total score, however, will be made **if no response** is indicated for an item in the Answer Sheet.
6. Handle the Test Booklet and Answer Sheet with care, **as under no circumstances (except for discrepancy in Test Booklet Code and Answer Sheet Code), another set will be provided.**
7. The candidates are not allowed to do any rough work or writing work on the Answer Sheet. All calculations/writing work are to be done in the space provided for this purpose in the Test Booklet itself, marked 'Space for Rough Work'. This space is given at the bottom of each page and in **three** pages (Pages 21 - 23) at the end of the booklet.
8. On completion of the test, the candidates must hand over the Answer Sheet to the Invigilator on duty in the Room/Hall. **However, the candidates are allowed to take away this Test Booklet with them.**
9. Each candidate must show on demand his/her Admit Card to the Invigilator.
10. No candidate, without special permission of the Superintendent or Invigilator, should leave his/her seat.
11. The candidates should not leave the Examination Hall without handing over their Answer Sheet to the Invigilator on duty and sign the Attendance Sheet again. Cases where a candidate has not signed the Attendance Sheet a second time will be deemed not to have handed over the Answer Sheet and dealt with as an unfair means case. **The candidates are also required to put their left hand THUMB impression in the space provided in the Attendance Sheet.**
12. Use of Electronic/Manual Calculator and any Electronic device like mobile phone, pager etc. is prohibited.
13. The candidates are governed by all Rules and Regulations of the JAB/Board with regard to their conduct in the Examination Hall. All cases of unfair means will be dealt with as per Rules and Regulations of the JAB/Board.
14. No part of the Test Booklet and Answer Sheet shall be detached under any circumstances.
15. **Candidates are not allowed to carry any textual material, printed or written, bits of papers, pager, mobile phone, electronic device or any other material except the Admit Card inside the examination room/hall.**

SEAL