

CODE

2**PAPER-2****P2-15-2****452572**

Time : 3 Hours

Maximum Marks : 240

READ THE INSTRUCTIONS CAREFULLY**GENERAL :**

1. This sealed booklet is your Question Paper. Do not break the seal till you are told to do so.
2. The question paper CODE is printed on the left hand top corner of this sheet and the right hand top corner of the back cover of this booklet.
3. Use the Optical Response Sheet (ORS) provided separately for answering the questions.
4. The ORS CODE is printed on its left part as well as the right part. Ensure that both these codes are identical and same as that on the question paper booklet. If not, contact the invigilator.
5. Blank spaces are provided within this booklet for rough work.
6. Write your name and roll number in the space provided on the back cover of this booklet.
7. After breaking the seal of the booklet, verify that the booklet contains 32 pages and that all the 60 questions along with the options are legible.

QUESTION PAPER FORMAT AND MARKING SCHEME :

8. The question paper has three parts: Physics, Chemistry and Mathematics. Each part has three sections.
9. Carefully read the instructions given at the beginning of each section.
10. Section 1 contains 8 questions. The answer to each question is a single digit integer ranging from 0 to 9 (both inclusive).
Marking scheme: +4 for correct answer and 0 in all other cases.
11. Section 2 contains 8 multiple choice questions with one or more than one correct option.
Marking scheme: +4 for correct answer, 0 if not attempted and -2 in all other cases.
12. Section 3 contains 2 "paragraph" type questions. Each paragraph describes an experiment, a situation or a problem. Two multiple choice questions will be asked based on this paragraph. One or more than one option can be correct.
Marking scheme: +4 for correct answer, 0 if not attempted and -2 in all other cases.

OPTICAL RESPONSE SHEET :

13. The ORS consists of an original (top sheet) and its carbon-less copy (bottom sheet).
14. Darken the appropriate bubbles on the original by applying sufficient pressure. This will leave an impression at the corresponding place on the carbon-less copy.
15. The original is machine-gradable and will be collected by the invigilator at the end of the examination.
16. You will be allowed to take away the carbon-less copy at the end of the examination.
17. Do not tamper with or mutilate the ORS.
18. Write your name, roll number and the name of the examination center and sign with pen in the space provided for this purpose on the original. **Do not write any of these details anywhere else.** Darken the appropriate bubble under each digit of your roll number.

Please see the last page of this booklet for rest of the instructions.

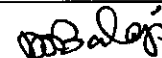

DO NOT BREAK THE SEAL WITHOUT BEING INSTRUCTED TO DO SO BY THE INVIGILATOR

SEAL

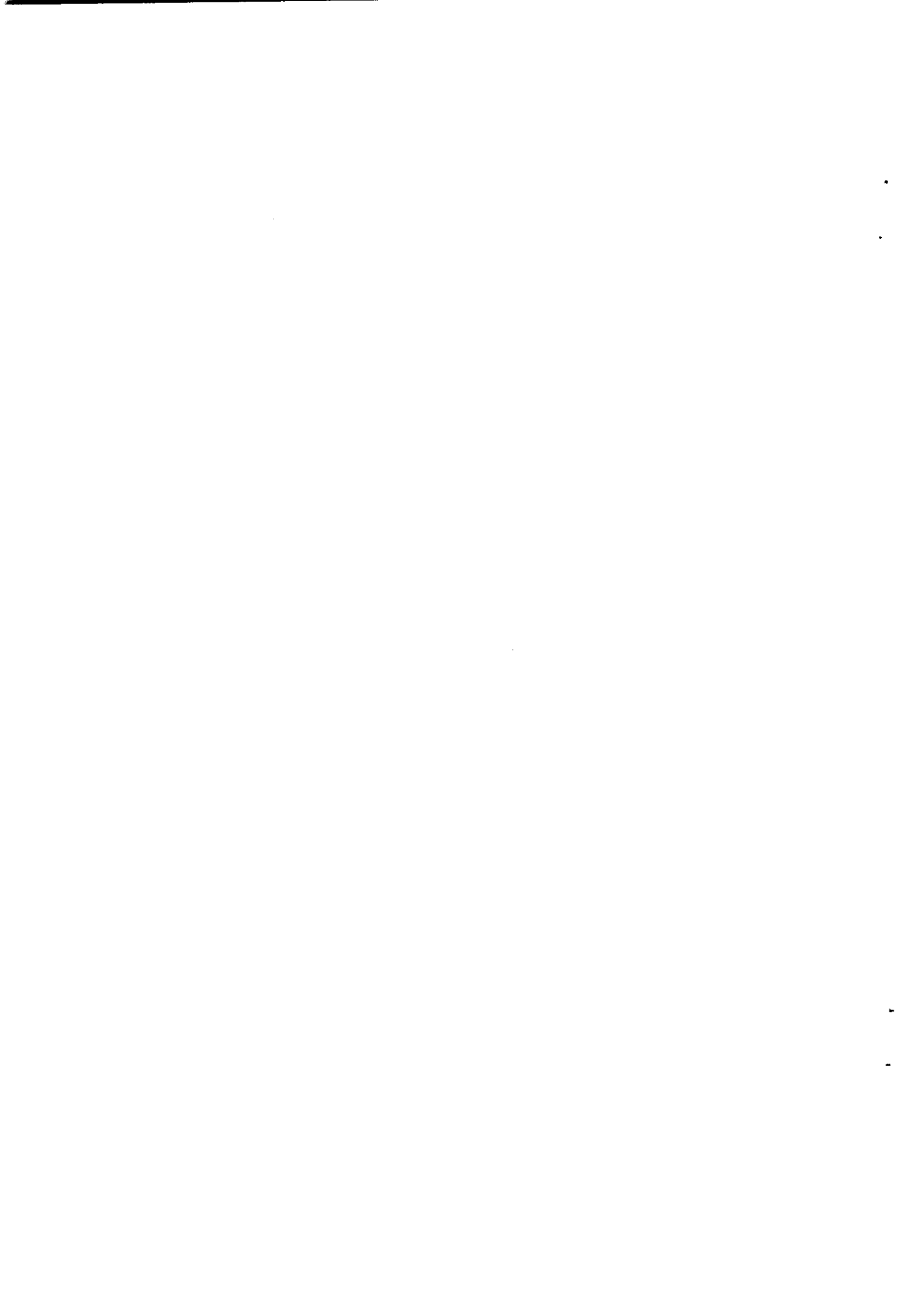

PART I : PHYSICS

SECTION 1 (Maximum Marks: 32)

- This section contains **EIGHT** questions
- The answer to each question is a **SINGLE DIGIT INTEGER** ranging from 0 to 9, both inclusive
- For each question, darken the bubble corresponding to the correct integer in the ORS
- Marking scheme:
 +4 If the bubble corresponding to the answer is darkened
 0 In all other cases

Q.1 3 Four harmonic waves of equal frequencies and equal intensities I_0 have phase angles $0, \pi/3, 2\pi/3$ and π . When they are superposed, the intensity of the resulting wave is nI_0 . The value of n is

Q.2 2 For a radioactive material, its activity A and rate of change of its activity R are defined as $A = -\frac{dN}{dt}$ and $R = -\frac{dA}{dt}$, where $N(t)$ is the number of nuclei at time t . Two radioactive sources P (mean life τ) and Q (mean life 2τ) have the same activity at $t = 0$. Their rates of change of activities at $t = 2\tau$ are R_P and R_Q , respectively. If $\frac{R_P}{R_Q} = \frac{n}{e}$, then the value of n is

Q.3 4 A monochromatic beam of light is incident at 60° on one face of an equilateral prism of refractive index n and emerges from the opposite face making an angle $\theta(n)$ with the normal (see the figure). For $n = \sqrt{3}$ the value of θ is 60° and $\frac{d\theta}{dn} = m$. The value of m is

$1 - \frac{\sqrt{3}}{2} = \sqrt{3} \sin \theta$

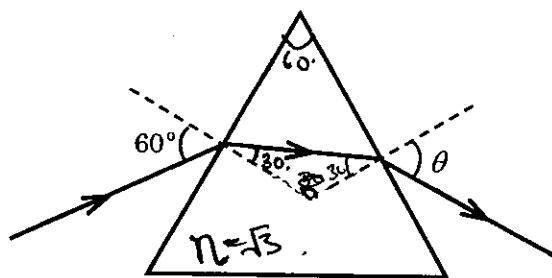

$\frac{N_P}{2\tau} = \frac{N_Q}{2\tau} = n$

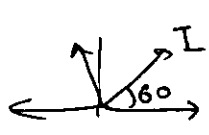

Space for rough work

$\frac{\sqrt{3}}{2} = n \sin \theta$
 $\sin^{-1}\left(\frac{\sqrt{3}}{2n}\right) = \theta$

$N_P = N_0 e^{-t/\tau}$
 $N_Q = 2N_0 e^{-t/2\tau}$

$A_P = \lambda_P \frac{1}{\tau} e^{-t/\tau} = n e^{-t/\tau}$

$A_Q = 2\lambda_Q \frac{1}{2\tau} e^{-t/2\tau} = n e^{-t/2\tau}$

$R_P = \frac{A_P}{\tau} e^{-t/\tau}$
 $R_Q = \frac{A_Q}{2\tau} e^{-t/2\tau}$

$2 \frac{e^{-2}}{e^{-1}}$

$N_P = N_0 e^{-t/\tau}$
 $N_Q = 2N_0 e^{-t/2\tau}$

Q.4 In the following circuit, the current through the resistor $R (= 2\Omega)$ is I Amperes. The value of I is

①

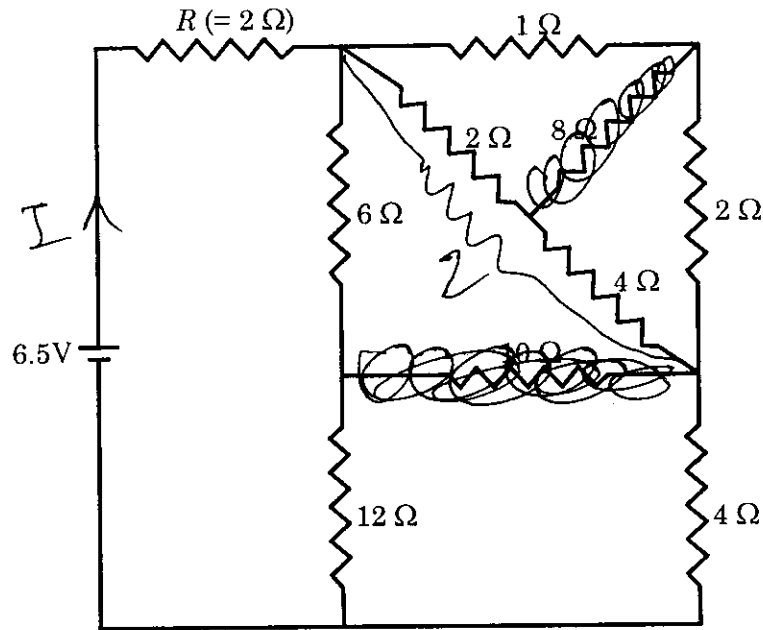

$h=3$

Q.5 An electron in an excited state of Li^{2+} ion has angular momentum $3h/2\pi$. The de Broglie wavelength of the electron in this state is $p\pi a_0$ (where a_0 is the Bohr radius). The value of p is

②

Space for rough work

$$\frac{1}{6} + \frac{1}{18} = \frac{1}{R}$$

$$\lambda = \frac{h}{p}$$

$$\frac{2\pi a_0}{3\pi}$$

$$m v \frac{3h}{2\pi}$$

m

$$\frac{18}{4} = 4.5$$

$$\frac{2}{3} \frac{h}{m}$$

- Q.6 A large spherical mass M is fixed at one position and two identical point masses m are kept on a line passing through the centre of M (see figure). The point masses are connected by a rigid massless rod of length l and this assembly is free to move along the line connecting them. All three masses interact only through their mutual gravitational interaction. When the point mass nearer to M is at a distance $r = 3l$ from M , the tension in the rod is zero for $m = k \left(\frac{M}{288} \right)$. The value of k is

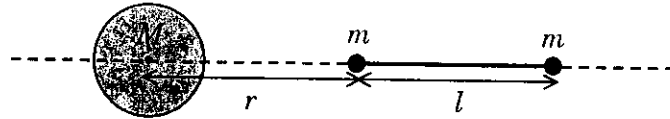

$$E = A^2 e^{-\alpha t}$$

- Q.7 The energy of a system as a function of time t is given as $E(t) = A^2 \exp(-\alpha t)$, where $\alpha = 0.2 \text{ s}^{-1}$. The measurement of A has an error of 1.25%. If the error in the measurement of time is 1.50%, the percentage error in the value of $E(t)$ at $t = 5 \text{ s}$ is

- Q.8 The densities of two solid spheres A and B of the same radii R vary with radial distance r as $\rho_A(r) = k \left(\frac{r}{R} \right)$ and $\rho_B(r) = k \left(\frac{r}{R} \right)^5$, respectively, where k is a constant. The moments of inertia of the individual spheres about axes passing through their centres are I_A and I_B , respectively. If $\frac{I_B}{I_A} = \frac{n}{10}$, the value of n is

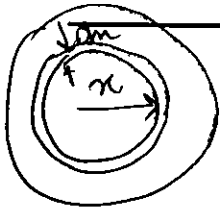

Space for rough work

$$\frac{2}{5} m R^2$$

$$\ln E = 2 \ln A - \alpha t$$

$$\frac{dE}{E} = \frac{2 dA}{A} + \frac{d(\alpha t)}{t}$$

$$= 2 \times 1.25 + 1.5$$

$$2.5$$

$$dm = 4\pi n^2 k \frac{n}{R} dn$$

$$dI = \frac{2}{5} n^2 4\pi n^2 R \frac{n^5}{R^5} dn$$

$$\frac{2}{5} 4\pi k \frac{n^9}{R^5}$$

$$dI = \frac{2}{5} dm n^2$$

$$= \frac{2}{5} \times 4\pi \times \frac{k}{R} n^5 dn$$

$$\frac{8\pi k}{5 R} \frac{R^6}{6}$$

$$\frac{8\pi k}{5 R}$$

SECTION 2 (Maximum Marks : 32)

- This section contains **EIGHT** questions
- Each question has **FOUR** options (A), (B), (C) and (D). **ONE OR MORE THAN ONE** of these four option(s) is(are) correct
- For each question, darken the bubble(s) corresponding to all the correct option(s) in the ORS
- Marking scheme :
 - +4 If only the bubble(s) corresponding to all the correct option(s) is(are) darkened
 - 0 If none of the bubbles is darkened
 - 2 In all other cases

Q.9 Consider a uniform spherical charge distribution of radius R_1 centred at the origin O. In this distribution, a spherical cavity of radius R_2 , centred at P with distance $OP = a = R_1 - R_2$ (see figure) is made. If the electric field inside the cavity at position \vec{r} is $\vec{E}(\vec{r})$, then the correct statement(s) is(are)

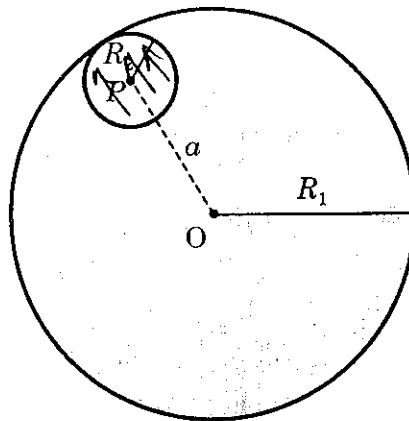

$$\frac{q}{3\epsilon_0}$$

- (A) \vec{E} is uniform, its magnitude is independent of R_2 but its direction depends on \vec{r}
- (B) \vec{E} is uniform, its magnitude depends on R_2 and its direction depends on \vec{r}
- (C) \vec{E} is uniform, its magnitude is independent of a but its direction depends on \vec{a}
- (D) \vec{E} is uniform and both its magnitude and direction depend on \vec{a}

Space for rough work

Q.10 In plotting stress versus strain curves for two materials P and Q , a student by mistake puts strain on the y -axis and stress on the x -axis as shown in the figure. Then the correct statement(s) is(are)

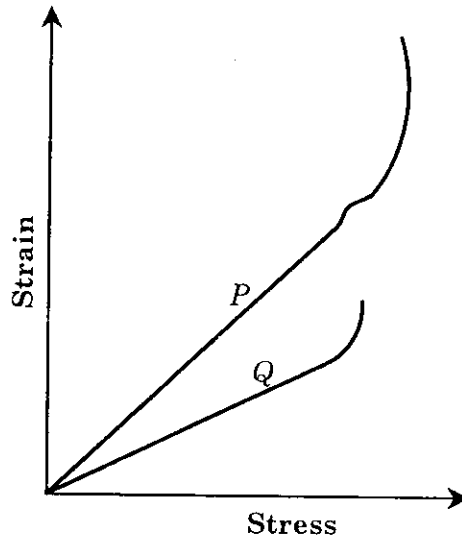

- (A) P has more tensile strength than Q
- (B) P is more ductile than Q
- (C) P is more brittle than Q
- (D) The Young's modulus of P is more than that of Q

Space for rough work

$Stress = \gamma Str$

Strain

Q
 P

Q.11 A spherical body of radius R consists of a fluid of constant density and is in equilibrium under its own gravity. If $P(r)$ is the pressure at r ($r < R$), then the correct option(s) is(are)

- (A) $P(r=0) = 0$ (B) $\frac{P(r=3R/4)}{P(r=2R/3)} = \frac{63}{80}$
 (C) $\frac{P(r=3R/5)}{P(r=2R/5)} = \frac{16}{21}$ (D) $\frac{P(r=R/2)}{P(r=R/3)} = \frac{20}{27}$

Q.12 A parallel plate capacitor having plates of area S and plate separation d , has capacitance C_1 in air. When two dielectrics of different relative permittivities ($\epsilon_1 = 2$ and $\epsilon_2 = 4$) are introduced between the two plates as shown in the figure, the capacitance becomes C_2 . The ratio $\frac{C_2}{C_1}$ is

$C_1 = \frac{\epsilon_0 A}{d} = C$

$C_2 = \frac{7C}{3}$

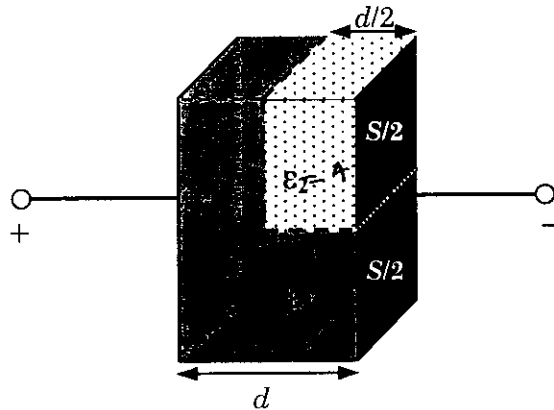

- (A) 6/5 (B) 5/3 (C) 7/5 (D) 7/3

Space for rough work

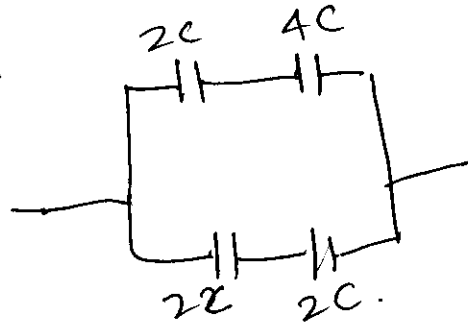
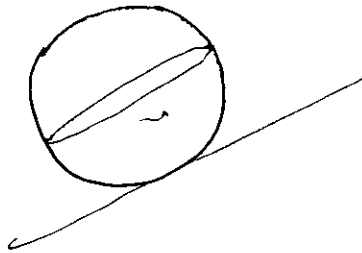

$C = \frac{\epsilon_0 A}{d}$

$\frac{1}{2} + \frac{1}{4}$

$\frac{4C}{3} + C$



PHYSICS

Q.13

An ideal monoatomic gas is confined in a horizontal cylinder by a spring loaded piston (as shown in the figure). Initially the gas is at temperature T_1 , pressure P_1 and volume V_1 and the spring is in its relaxed state. The gas is then heated very slowly to temperature T_2 , pressure P_2 and volume V_2 . During this process the piston moves out by a distance x . Ignoring the friction between the piston and the cylinder, the correct statement(s) is(are)

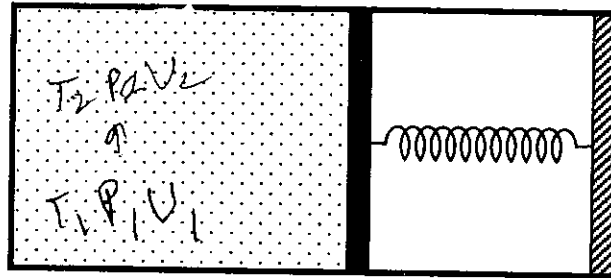

- (A) If $V_2 = 2V_1$ and $T_2 = 3T_1$, then the energy stored in the spring is $\frac{1}{4}P_1V_1$
- (B) If $V_2 = 2V_1$ and $T_2 = 3T_1$, then the change in internal energy is $3P_1V_1$
- (C) If $V_2 = 3V_1$ and $T_2 = 4T_1$, then the work done by the gas is $\frac{7}{3}P_1V_1$
- (D) If $V_2 = 3V_1$ and $T_2 = 4T_1$, then the heat supplied to the gas is $\frac{17}{6}P_1V_1$

Space for rough work



Q.14 A fission reaction is given by ${}_{92}^{236}\text{U} \rightarrow {}_{54}^{140}\text{Xe} + {}_{38}^{94}\text{Sr} + x + y$, where x and y are two particles. Considering ${}_{92}^{236}\text{U}$ to be at rest, the kinetic energies of the products are denoted by K_{Xe} , K_{Sr} , K_x (2 MeV) and K_y (2 MeV), respectively. Let the binding energies per nucleon of ${}_{92}^{236}\text{U}$, ${}_{54}^{140}\text{Xe}$ and ${}_{38}^{94}\text{Sr}$ be 7.5 MeV, 8.5 MeV and 8.5 MeV, respectively. Considering different conservation laws, the correct option(s) is(are)

- (A) $x = n, y = n, K_{\text{Sr}} = 129 \text{ MeV}, K_{\text{Xe}} = 86 \text{ MeV}$
- (B) $x = p, y = e^-, K_{\text{Sr}} = 129 \text{ MeV}, K_{\text{Xe}} = 86 \text{ MeV}$
- (C) $x = p, y = n, K_{\text{Sr}} = 129 \text{ MeV}, K_{\text{Xe}} = 86 \text{ MeV}$
- (D) $x = n, y = n, K_{\text{Sr}} = 86 \text{ MeV}, K_{\text{Xe}} = 129 \text{ MeV}$

Space for rough work

$$54 \times 8.5 + 8.5 \times 92$$

$$934$$

$$54 \times 8.5 + 8.5 \times 92$$

$$92(8.5) - 92(7.5)$$

$$\textcircled{92}$$

$$934$$

$$B = \frac{\mu_0 I}{2\pi r}$$

$$M I^{-2} T^{-2} L$$

Q.15 Two spheres P and Q of equal radii have densities ρ_1 and ρ_2 , respectively. The spheres are connected by a massless string and placed in liquids L_1 and L_2 of densities σ_1 and σ_2 and viscosities η_1 and η_2 , respectively. They float in equilibrium with the sphere P in L_1 and sphere Q in L_2 and the string being taut (see figure). If sphere P alone in L_2 has terminal velocity \vec{V}_P and Q alone in L_1 has terminal velocity \vec{V}_Q , then

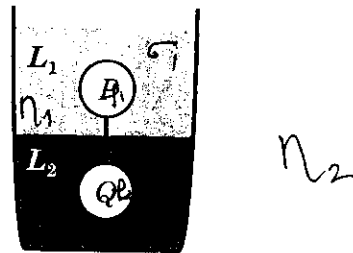

- (A) $\frac{|\vec{V}_P|}{|\vec{V}_Q|} = \frac{\eta_1}{\eta_2}$ (B) $\frac{|\vec{V}_P|}{|\vec{V}_Q|} = \frac{\eta_2}{\eta_1}$ (C) $\vec{V}_P \cdot \vec{V}_Q > 0$ (D) $\vec{V}_P \cdot \vec{V}_Q < 0$

Q.16 In terms of potential difference V , electric current I , permittivity ϵ_0 , permeability μ_0 and speed of light c , the dimensionally correct equation(s) is(are)

- (A) $\mu_0 I^2 = \epsilon_0 V^2$ (B) $\epsilon_0 I = \mu_0 V$ (C) $I = \frac{\epsilon_0 c V}{\mu_0}$ (D) $\mu_0 c I = \epsilon_0 V$

Space for rough work

$$V = \frac{W}{q} = \frac{Fd}{q} = \frac{MLT^{-2}L}{IT}$$

$$\mu_0 c^2 = 1$$

$$\begin{aligned} c &= LT^{-1} \\ V &= ML^2 T^{-3} I^{-1} \\ I &= I \\ \epsilon_0 &= M^{-1} L^{-3} T^4 I \\ \mu_0 &= MLT^{-2} I^{-2} \end{aligned}$$

$$\epsilon_0: F = \frac{1}{4\pi\epsilon_0} \frac{q_1 q_2}{r^2} \Rightarrow \epsilon_0 = \frac{I^2 T^2 L^{-2}}{MLT^{-2}} = M^{-1} I^2 T^4 L^{-3}$$

$$MLT^{-2} = MLT^{-2}$$

B $\frac{\mu_0}{4\pi}$

$$F = BIL$$

$$MLT^{-2} = B I L$$

$$MI^{-1} T^{-2} = \frac{\mu_0}{4\pi}$$

SECTION 3 (Maximum Marks : 16)

- This section contains **TWO** paragraphs
- Based on each paragraph, there will be **TWO** questions
- Each question has **FOUR** options (A), (B), (C) and (D). **ONE OR MORE THAN ONE** of these four option(s) is(are) correct
- For each question, darken the bubble(s) corresponding to all the correct option(s) in the ORS
- Marking scheme :
 - +4 If only the bubble(s) corresponding to all the correct option(s) is(are) darkened
 - 0 If none of the bubbles is darkened
 - 2 In all other cases

Space for rough work

PARAGRAPH 1

Light guidance in an optical fiber can be understood by considering a structure comprising of thin solid glass cylinder of refractive index n_1 surrounded by a medium of lower refractive index n_2 . The light guidance in the structure takes place due to successive total internal reflections at the interface of the media n_1 and n_2 as shown in the figure. All rays with the angle of incidence i less than a particular value i_m are confined in the medium of refractive index n_1 . The numerical aperture (NA) of the structure is defined as $\sin i_m$.

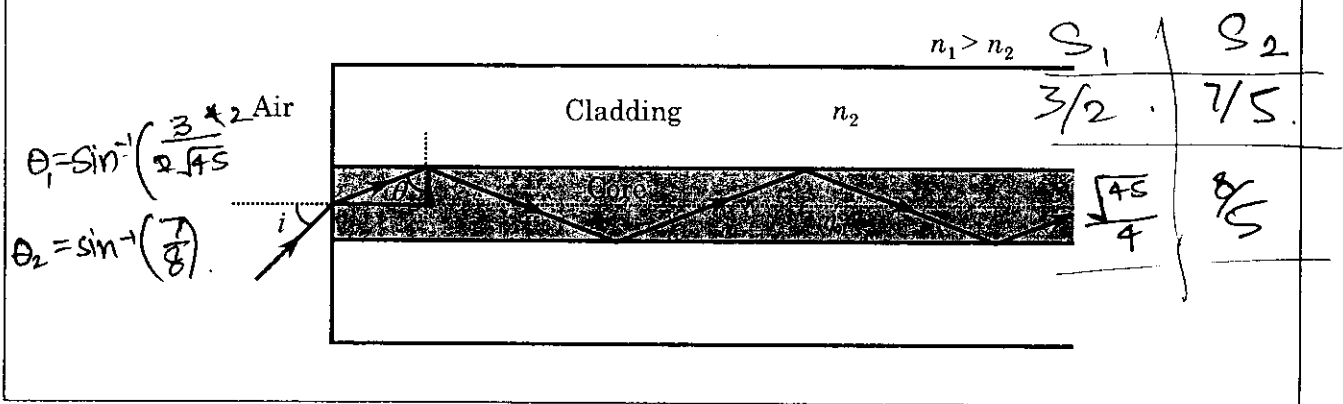

Q.17 For two structures namely S_1 with $n_1 = \sqrt{45}/4$ and $n_2 = 3/2$, and S_2 with $n_1 = 8/5$ and $n_2 = 7/5$ and taking the refractive index of water to be $4/3$ and that of air to be 1 , the correct option(s) is(are)

- (A) NA of S_1 immersed in water is the same as that of S_2 immersed in a liquid of refractive index $\frac{16}{3\sqrt{15}}$
- (B) NA of S_1 immersed in liquid of refractive index $\frac{6}{\sqrt{15}}$ is the same as that of S_2 immersed in water
- (C) NA of S_1 placed in air is the same as that of S_2 immersed in liquid of refractive index $\frac{4}{\sqrt{15}}$
- (D) NA of S_1 placed in air is the same as that of S_2 placed in water

Q.18 If two structures of same cross-sectional area, but different numerical apertures NA_1 and NA_2 ($NA_2 < NA_1$) are joined longitudinally, the numerical aperture of the combined structure is

- (A) $\frac{NA_1 NA_2}{NA_1 + NA_2}$
- (B) $NA_1 + NA_2$
- (C) NA_1
- (D) NA_2

Space for rough work

PARAGRAPH 2

In a thin rectangular metallic strip a constant current I flows along the positive x -direction, as shown in the figure. The length, width and thickness of the strip are l , w and d , respectively.

A uniform magnetic field \vec{B} is applied on the strip along the positive y -direction. Due to this, the charge carriers experience a net deflection along the z -direction. This results in accumulation of charge carriers on the surface $PQRS$ and appearance of equal and opposite charges on the face opposite to $PQRS$. A potential difference along the z -direction is thus developed. Charge accumulation continues until the magnetic force is balanced by the electric force. The current is assumed to be uniformly distributed on the cross section of the strip and carried by electrons.

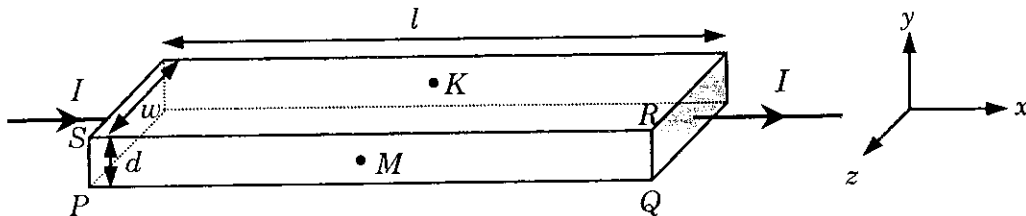

Q.19 Consider two different metallic strips (1 and 2) of the same material. Their lengths are the same, widths are w_1 and w_2 and thicknesses are d_1 and d_2 , respectively. Two points K and M are symmetrically located on the opposite faces parallel to the x - y plane (see figure). V_1 and V_2 are the potential differences between K and M in strips 1 and 2, respectively. Then, for a given current I flowing through them in a given magnetic field strength B , the correct statement(s) is(are)

- (A) If $w_1 = w_2$ and $d_1 = 2d_2$, then $V_2 = 2V_1$
- (B) If $w_1 = w_2$ and $d_1 = 2d_2$, then $V_2 = V_1$
- (C) If $w_1 = 2w_2$ and $d_1 = d_2$, then $V_2 = 2V_1$
- (D) If $w_1 = 2w_2$ and $d_1 = d_2$, then $V_2 = V_1$

$V = Ed$

Q.20 Consider two different metallic strips (1 and 2) of same dimensions (length l , width w and thickness d) with carrier densities n_1 and n_2 , respectively. Strip 1 is placed in magnetic field B_1 and strip 2 is placed in magnetic field B_2 , both along positive y -directions. Then V_1 and V_2 are the potential differences developed between K and M in strips 1 and 2, respectively. Assuming that the current I is the same for both the strips, the correct option(s) is(are)

- (A) If $B_1 = B_2$ and $n_1 = 2n_2$, then $V_2 = 2V_1$
- (B) If $B_1 = B_2$ and $n_1 = 2n_2$, then $V_2 = V_1$
- (C) If $B_1 = 2B_2$ and $n_1 = n_2$, then $V_2 = 0.5V_1$
- (D) If $B_1 = 2B_2$ and $n_1 = n_2$, then $V_2 = V_1$

END OF PART I : PHYSICS

PART II : CHEMISTRY

SECTION 1 (Maximum Marks: 32)

- This section contains **EIGHT** questions
- The answer to each question is a **SINGLE DIGIT INTEGER** ranging from 0 to 9, both inclusive
- For each question, darken the bubble corresponding to the correct integer in the ORS
- Marking scheme:
+4 If the bubble corresponding to the answer is darkened
0 In all other cases

Q.21 Among the complex ions, $[\text{Co}(\text{NH}_2\text{-CH}_2\text{-CH}_2\text{-NH}_2)_2\text{Cl}_2]^+$, $[\text{CrCl}_2(\text{C}_2\text{O}_4)_2]^{3-}$, $[\text{Fe}(\text{H}_2\text{O})_4(\text{OH})_2]^+$, $[\text{Fe}(\text{NH}_3)_2(\text{CN})_4]^-$, $[\text{Co}(\text{NH}_2\text{-CH}_2\text{-CH}_2\text{-NH}_2)_2(\text{NH}_3)\text{Cl}]^{2+}$ and $[\text{Co}(\text{NH}_3)_4(\text{H}_2\text{O})\text{Cl}]^{2+}$, the number of complex ion(s) that show(s) *cis-trans* isomerism is

(A)

Q.22 Three moles of B_2H_6 are completely reacted with methanol. The number of moles of boron containing product formed is

(A)

Q.23 The molar conductivity of a solution of a weak acid HX (0.01 M) is 10 times smaller than the molar conductivity of a solution of a weak acid HY (0.10 M). If $\lambda_{\text{X}^-}^0 \approx \lambda_{\text{Y}^-}^0$, the difference in their $\text{p}K_a$ values, $\text{p}K_a(\text{HX}) - \text{p}K_a(\text{HY})$, is (consider degree of ionization of both acids to be $\ll 1$)

(2)

Q.24 A closed vessel with rigid walls contains 1 mol of $^{238}_{92}\text{U}$ and 1 mol of air at 298 K. Considering complete decay of $^{238}_{92}\text{U}$ to $^{206}_{82}\text{Pb}$, the ratio of the final pressure to the initial pressure of the system at 298 K is

(9)

Q.25 In dilute aqueous H_2SO_4 , the complex diaquodioxalatoferate(II) is oxidized by MnO_4^- . For this reaction, the ratio of the rate of change of $[\text{H}^+]$ to the rate of change of $[\text{MnO}_4^-]$ is

(5)

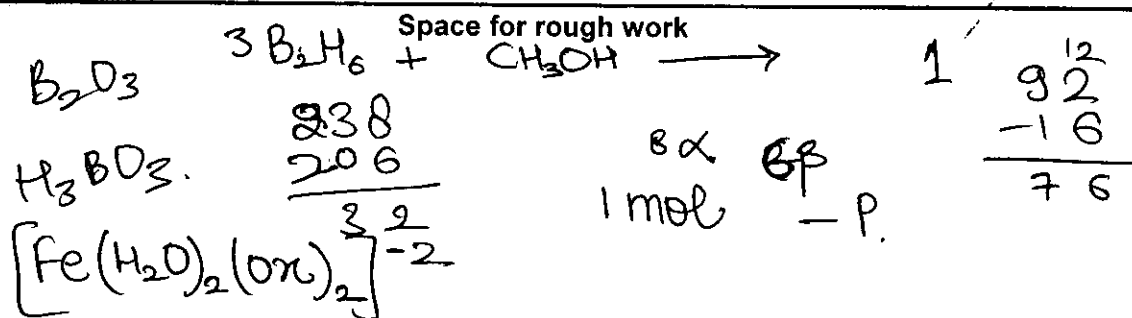

Q.26 The number of hydroxyl group(s) in Q is

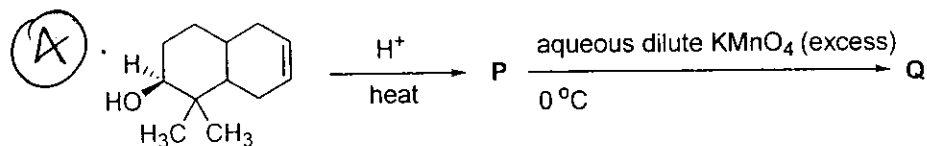

Q.27 Among the following, the number of reaction(s) that produce(s) benzaldehyde is

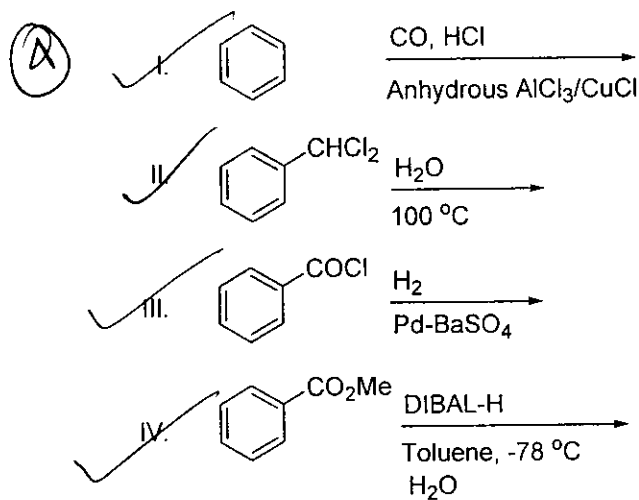

Q.28 In the complex acetyl bromido dicarbonyl bis(triethylphosphine)iron(II), the number of Fe-C bond(s) is

Space for rough work

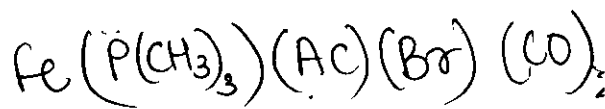
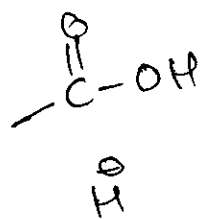

SECTION 2 (Maximum Marks: 32)

- This section contains **EIGHT** questions.
- Each question has **FOUR** options (A), (B), (C) and (D). **ONE OR MORE THAN ONE** of these four option(s) is(are) correct
- For each question, darken the bubble(s) corresponding to all the correct option(s) in the ORS
- Marking scheme:
 +4 If only the bubble(s) corresponding to all the correct option(s) is(are) darkened
 0 If none of the bubbles is darkened
 -2 In all other cases

Q.29 In the following reactions, the major product W is

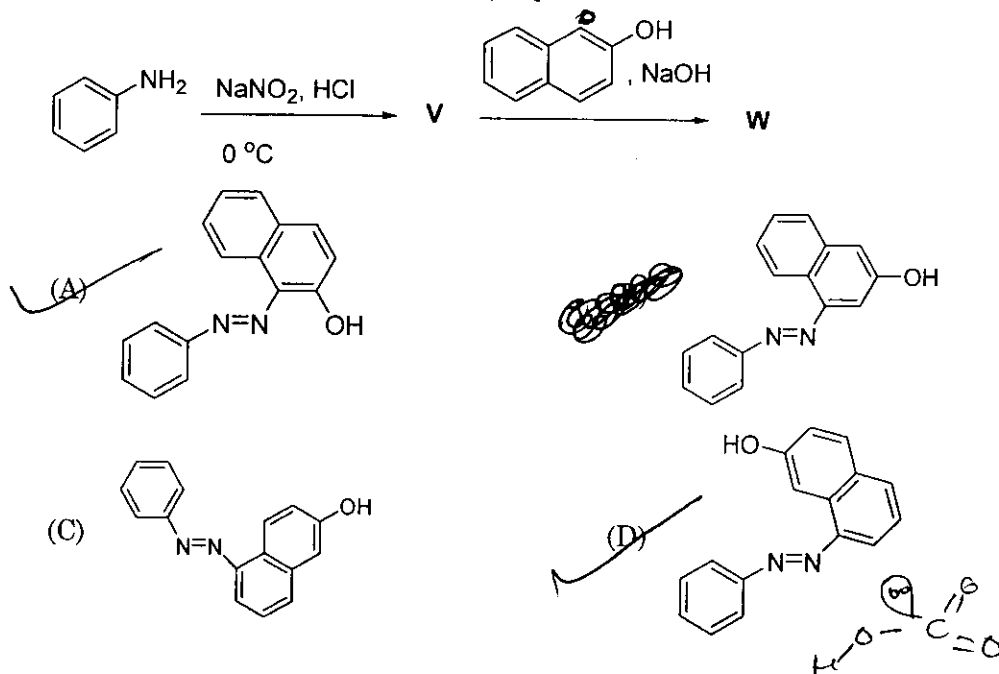

Q.30 The correct statement(s) regarding, (i) HClO , (ii) HClO_2 , (iii) HClO_3 and (iv) HClO_4 , is(are)

- (A) The number of $\text{Cl}=\text{O}$ bonds in (ii) and (iii) together is two
- (B) The number of lone pairs of electrons on Cl in (ii) and (iii) together is three
- (C) The hybridization of Cl in (iv) is sp^3
- (D) Amongst (i) to (iv), the strongest acid is (i)

Q.31 The pair(s) of ions where BOTH the ions are precipitated upon passing H_2S gas in presence of dilute HCl , is(are)

- (A) $\text{Ba}^{2+}, \text{Zn}^{2+}$
- (B) $\text{Bi}^{3+}, \text{Fe}^{3+}$
- (C) $\text{Cu}^{2+}, \text{Pb}^{2+}$
- (D) $\text{Hg}^{2+}, \text{Bi}^{3+}$

Space for rough work

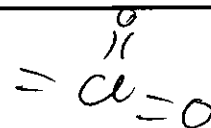

Q.32 Under hydrolytic conditions, the compounds used for preparation of linear polymer and for chain termination, respectively, are

- (A) CH_3SiCl_3 and $\text{Si}(\text{CH}_3)_4$ (B) $(\text{CH}_3)_2\text{SiCl}_2$ and $(\text{CH}_3)_3\text{SiCl}$
 (C) $(\text{CH}_3)_2\text{SiCl}_2$ and CH_3SiCl_3 (D) SiCl_4 and $(\text{CH}_3)_3\text{SiCl}$

Q.33 When O_2 is adsorbed on a metallic surface, electron transfer occurs from the metal to O_2 . The TRUE statement(s) regarding this adsorption is(are)

- (A) O_2 is physisorbed (B) heat is released
 (C) occupancy of π_{2p}^* of O_2 is increased (D) bond length of O_2 is increased

Q.34 One mole of a monoatomic real gas satisfies the equation $p(V-b) = RT$ where b is a constant. The relationship of interatomic potential $V(r)$ and interatomic distance r for the gas is given by

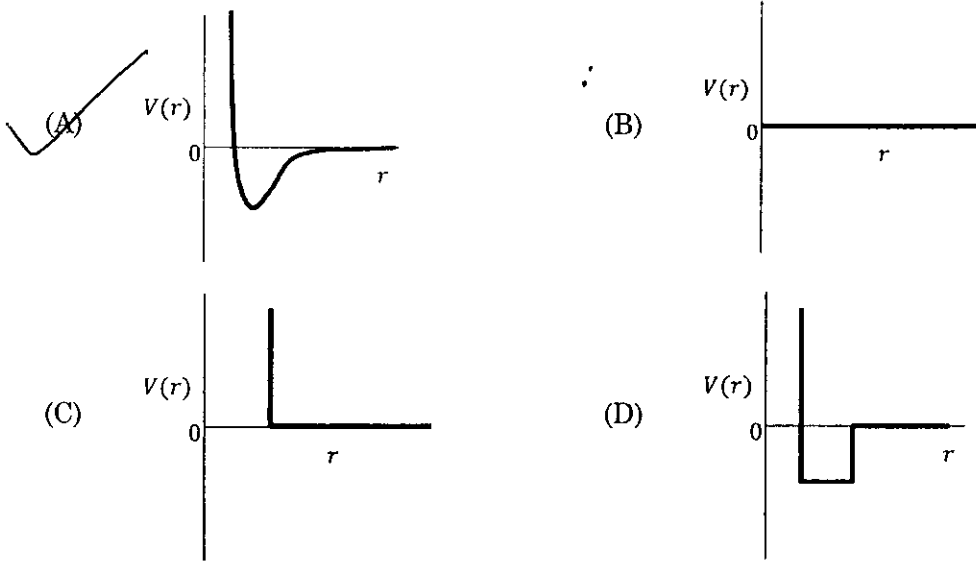

Space for rough work

Handwritten scribbles and numbers: 2-2, 2-2

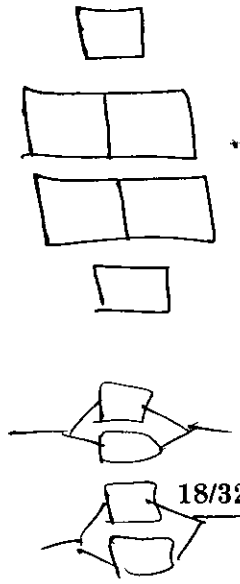

2
1
2
1

Q.35 In the following reactions, the product S is

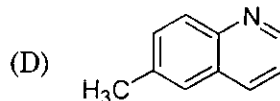
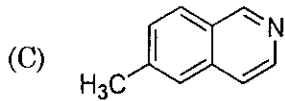
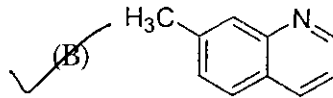
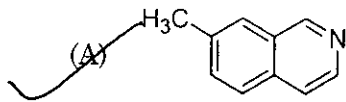
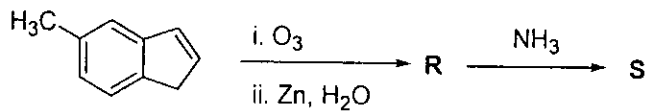

Q.36 The major product U in the following reactions is

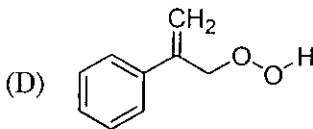
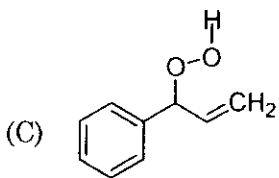
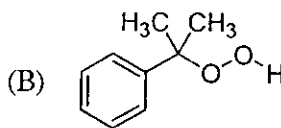
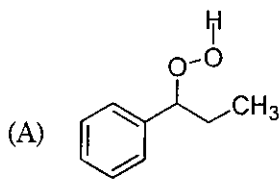
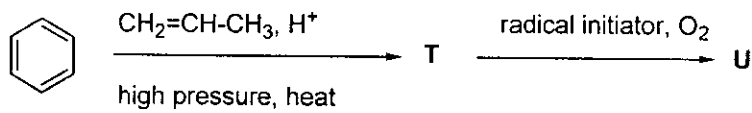

Space for rough work

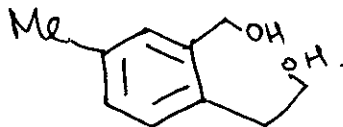

SECTION 3 (Maximum Marks: 16)

- This section contains **TWO** paragraphs
- Based on each paragraph, there will be **TWO** questions
- Each question has **FOUR** options (A), (B), (C) and (D). **ONE OR MORE THAN ONE** of these four option(s) is(are) correct
- For each question, darken the bubble(s) corresponding to all the correct option(s) in the ORS
- Marking scheme:
 - +4 If only the bubble(s) corresponding to all the correct option(s) is(are) darkened
 - 0 If none of the bubbles is darkened
 - 2 In all other cases

PARAGRAPH 1

When 100 mL of 1.0 M HCl was mixed with 100 mL of 1.0 M NaOH in an insulated beaker at constant pressure, a temperature increase of 5.7°C was measured for the beaker and its contents (**Expt. 1**). Because the enthalpy of neutralization of a strong acid with a strong base is a constant ($-57.0 \text{ kJ mol}^{-1}$), this experiment could be used to measure the calorimeter constant.

In a second experiment (**Expt. 2**), 100 mL of 2.0 M acetic acid ($K_a = 2.0 \times 10^{-5}$) was mixed with 100 mL of 1.0 M NaOH (under identical conditions to **Expt. 1**) where a temperature rise of 5.6°C was measured.

(Consider heat capacity of all solutions as $4.2 \text{ J g}^{-1} \text{ K}^{-1}$ and density of all solutions as 1.0 g mL^{-1})

Q.37 Enthalpy of dissociation (in kJ mol^{-1}) of acetic acid obtained from the **Expt. 2** is ,

- (A) 1.0 (B) 10.0 (C) 24.5 (D) 51.4

Q.38 The pH of the solution after **Expt. 2** is

- (A) 2.8 (B) 4.7 (C) 5.0 (D) 7.0

Space for rough work



$$\frac{1}{2} (4.7 + \log 5)$$

5.1

PARAGRAPH 2

In the following reactions

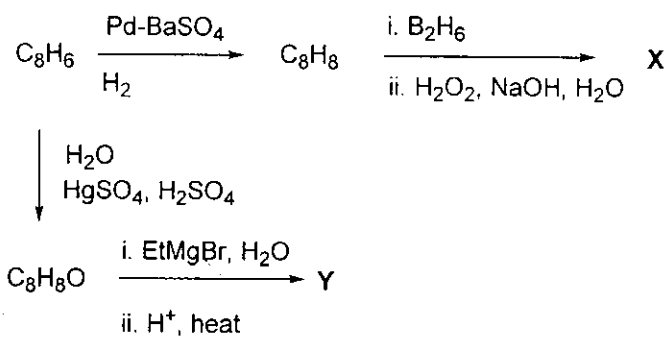

Q.39 Compound X is

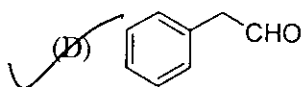
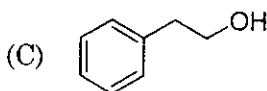
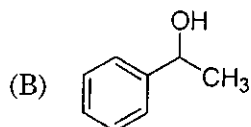
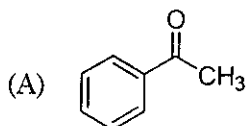

Q.40 The major compound Y is

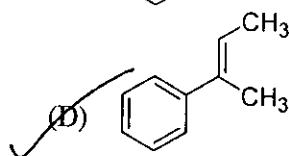
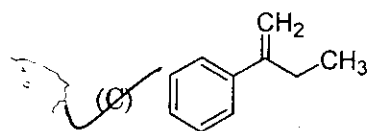
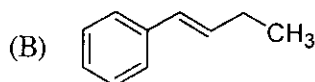
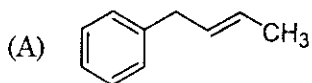

END OF PART II : CHEMISTRY

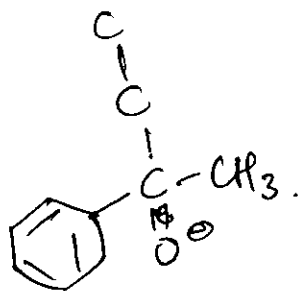

PART III : MATHEMATICS

SECTION 1 (Maximum Marks: 32)

- This section contains **EIGHT** questions
- The answer to each question is a **SINGLE DIGIT INTEGER** ranging from 0 to 9, both inclusive
- For each question, darken the bubble corresponding to the correct integer in the ORS
- Marking scheme:
 - +4 If the bubble corresponding to the answer is darkened
 - 0 In all other cases

Q.41 Suppose that the foci of the ellipse $\frac{x^2}{9} + \frac{y^2}{5} = 1$ are $(f_1, 0)$ and $(f_2, 0)$ where $f_1 > 0$ and $f_2 < 0$.

(A) Let P_1 and P_2 be two parabolas with a common vertex at $(0, 0)$ and with foci at $(f_1, 0)$ and $(2f_2, 0)$, respectively. Let T_1 be a tangent to P_1 which passes through $(2f_2, 0)$ and T_2 be a tangent to P_2 which passes through $(f_1, 0)$. If m_1 is the slope of T_1 and m_2 is the slope of T_2 , then the value of $\left(\frac{1}{m_1^2} + m_2^2\right)$ is

Q.42 Let m and n be two positive integers greater than 1. If

(2) $\lim_{\alpha \rightarrow 0} \left(\frac{e^{\cos(\alpha^n)} - e}{\alpha^m} \right) = -\left(\frac{e}{2}\right)$

then the value of $\frac{m}{n}$ is

$m, n > 1$

$$\frac{e}{\alpha^m} (\cos \alpha^n - 1) = \frac{e (e^{\cos \alpha^n} - 1)}{\alpha^m} \Big|_0$$

(9) Q.43 If

$$\alpha = \int_0^1 (e^{9x+3\tan^{-1}x}) \left(\frac{12+9x^2}{1+x^2} \right) dx$$

where $\tan^{-1}x$ takes only principal values, then the value of $\left(\log_e |1+\alpha| - \frac{3\pi}{4}\right)$ is

$e^{9n+3\tan^{-1}n} = t$

$$\frac{e^{9n+3\tan^{-1}n}}{e^{9n+3\tan^{-1}n}} = \frac{9 + \frac{3}{1+n^2}}{1+n^2}$$

$$y = mn + \frac{2}{m}$$

$$0 = -4m + \frac{2}{m}$$

$$4m^2 = 2 \quad m^2 = \frac{1}{2}$$

$$\frac{e^{\cos \alpha^n} (-\sin \alpha^n) n \alpha^{n-1}}{m \alpha^{m-1}} = \frac{e}{2}$$

$$\frac{+e^{\cos \alpha^n} \sin \alpha^n}{\alpha^{m-n}} \cdot \frac{n}{m} = +\frac{e}{2}$$

Space for rough work

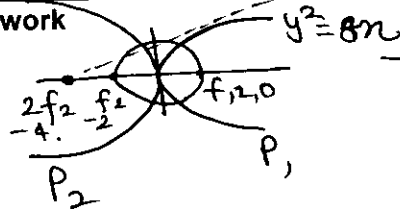

$$y^2 = 8x$$

$$e = \sqrt{1 - \frac{5}{9}} = \frac{2}{3}$$

$$y = mn - \frac{4}{m}$$

$$\frac{4}{m} = 2m$$

$f(-1) = 0$

Q.44 Let $f: \mathbb{R} \rightarrow \mathbb{R}$ be a continuous odd function, which vanishes exactly at one point and $f(1) = \frac{1}{2}$. Suppose that $F(x) = \int_{-1}^x f(t) dt$ for all $x \in [-1, 2]$ and $G(x) = \int_{-1}^x t|f(f(t))| dt$ for all $x \in [-1, 2]$. If $\lim_{x \rightarrow 1} \frac{F(x)}{G(x)} = \frac{1}{14}$, then the value of $f\left(\frac{1}{2}\right)$ is

7

Q.45 Suppose that \vec{p} , \vec{q} and \vec{r} are three non-coplanar vectors in \mathbb{R}^3 . Let the components of a vector \vec{s} along \vec{p} , \vec{q} and \vec{r} be 4, 3 and 5, respectively. If the components of this vector \vec{s} along $(-\vec{p} + \vec{q} + \vec{r})$, $(\vec{p} - \vec{q} + \vec{r})$ and $(-\vec{p} - \vec{q} + \vec{r})$ are x , y and z , respectively, then the value of $2x + y + z$ is

4

Space for rough work

$$\frac{\int_{-1}^x f(t) dt}{\int_{-1}^x t|f(f(t))| dt} = \frac{f(x)}{x|f(f(x))|} = \frac{\frac{1}{2}}{1|f(\frac{1}{2})|} = \frac{1}{14}$$

$$\vec{s} = 4\hat{i} + 3\hat{j} + 5\hat{k} \cdot \frac{(-\hat{i} + \hat{j} + \hat{k})}{\sqrt{3}}$$

9-

$$\frac{-4 + 3 + 5}{\sqrt{3}} + \frac{4 - 3 + 5}{\sqrt{3}} +$$

~~$\frac{24}{\sqrt{3}}$~~ ~~$\frac{28}{\sqrt{3}}$~~

$$2(4 + 3 + 5) \cdot \frac{2 \times 12}{\sqrt{3}}$$

$$\frac{4}{\sqrt{3}} + \frac{6}{\sqrt{3}} - \frac{2}{\sqrt{3}} \quad -4 - 3 + 5$$

$$\frac{12}{\sqrt{3}} \quad 4\sqrt{3}$$

$$\alpha_k = e^{i \frac{k\pi}{7}}$$

Q.46 For any integer k , let $\alpha_k = \cos\left(\frac{k\pi}{7}\right) + i \sin\left(\frac{k\pi}{7}\right)$, where $i = \sqrt{-1}$. The value of the expression

$$\frac{\sum_{k=1}^{12} |\alpha_{k+1} - \alpha_k|}{\sum_{k=1}^3 |\alpha_{4k-1} - \alpha_{4k-2}|}$$
 is

Q.47 Suppose that all the terms of an arithmetic progression (A.P.) are natural numbers. If the ratio of the sum of the first seven terms to the sum of the first eleven terms is $6 : 11$ and the seventh term lies in between 130 and 140, then the common difference of this A.P. is

Q.48 The coefficient of x^9 in the expansion of $(1+x)(1+x^2)(1+x^3)\dots(1+x^{100})$ is

Space for rough work

$(\alpha_2 - \alpha_1) + (\alpha_3 - \alpha_2) + \dots$
 $\frac{7}{2} [2a + 6d] = \frac{6}{11}$
 $\frac{11}{2} [2a + 10d]$
 $\frac{7}{11} \left[\frac{a+3d}{a+5d} \right] = \frac{6}{11}$
 $7a + 21d = 6a + 30d$
 $a = 9d$

$1+3^{-1}C_{3-1}$
 $9+1^{-1}C_{1-1}$
 $3C_0$
 $C_0 + 9+2^{-1}C_{2-1}$
 $9C_0 + 10C_1 + 11C_2 + \dots$

$130 < a + 6d < 140$
 $10 <$
 $\frac{130}{15} < d < \frac{140}{15}$
 $26 < d < 30$
 3

$5 \overline{) 130} \begin{matrix} 2 \\ 10 \end{matrix}$
 9

9
 81
 72
 63
 54

521
 432
 581

612
 531
 7
 43
 3
 1234

SECTION 2 (Maximum Marks: 32)

- This section contains **EIGHT** questions
- Each question has **FOUR** options (A), (B), (C) and (D). **ONE OR MORE THAN ONE** of these four option(s) is(are) correct
- For each question, darken the bubble(s) corresponding to all the correct option(s) in the ORS
- Marking scheme:
 +4 If only the bubble(s) corresponding to all the correct option(s) is(are) darkened
 0 If none of the bubbles is darkened
 -2 In all other cases

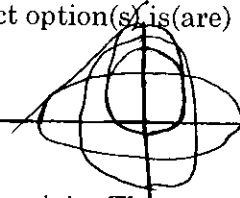

Q.49 Let E_1 and E_2 be two ellipses whose centers are at the origin. The major axes of E_1 and E_2 lie along the x -axis and the y -axis, respectively. Let S be the circle $x^2 + (y-1)^2 = 2$. The straight line $x+y=3$ touches the curves S , E_1 and E_2 at P , Q and R , respectively. Suppose that $PQ = PR = \frac{2\sqrt{2}}{3}$. If e_1 and e_2 are the eccentricities of E_1 and E_2 , respectively, then the correct expression(s) is(are)

- (A) $e_1^2 + e_2^2 = \frac{43}{40}$ (B) $e_1 e_2 = \frac{\sqrt{7}}{2\sqrt{10}}$ (C) $|e_1^2 - e_2^2| = \frac{5}{8} \frac{25}{40}$ (D) $e_1 e_2 = \frac{\sqrt{3}}{4}$

Q.50 Consider the hyperbola $H: x^2 - y^2 = 1$ and a circle S with center $N(x_2, 0)$. Suppose that H and S touch each other at a point $P(x_1, y_1)$ with $x_1 > 1$ and $y_1 > 0$. The common tangent to H and S at P intersects the x -axis at point M . If (l, m) is the centroid of the triangle ΔPMN , then the correct expression(s) is(are)

- (A) $\frac{dl}{dx_1} = 1 - \frac{1}{3x_1^2}$ for $x_1 > 1$ (B) $\frac{dm}{dx_1} = \frac{x_1}{3(\sqrt{x_1^2 - 1})}$ for $x_1 > 1$
 (C) $\frac{dl}{dx_1} = 1 + \frac{1}{3x_1^2}$ for $x_1 > 1$ (D) $\frac{dm}{dy_1} = \frac{1}{3}$ for $y_1 > 0$

$n_1 - n_2 = 25$

$n_1 + n_2 = 43$

$2n_1 = 68$

$n_1 = 34 \quad n_2 = 9$

Space for rough work

$e_1^2 = \frac{34}{40} \quad e_2^2 = \frac{9}{40}$

$e_1 = \frac{\sqrt{34}}{2\sqrt{10}} = \frac{3}{2\sqrt{10}}$

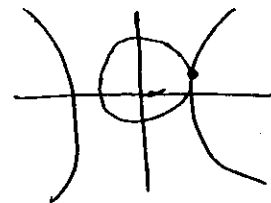

Q.51 The option(s) with the values of a and L that satisfy the following equation is(are)

$$\frac{\int_0^{4\pi} e^t (\sin^6 at + \cos^4 at) dt}{\int_0^{\pi} e^t (\sin^6 at + \cos^4 at) dt} = L ?$$

✓ (A) $a = 2, L = \frac{e^{4\pi} - 1}{e^{\pi} - 1}$

(B) $a = 2, L = \frac{e^{4\pi} + 1}{e^{\pi} + 1}$

✓ (C) $a = 4, L = \frac{e^{4\pi} - 1}{e^{\pi} - 1}$

(D) $a = 4, L = \frac{e^{4\pi} + 1}{e^{\pi} + 1}$

Q.52 Let $f, g: [-1, 2] \rightarrow \mathbb{R}$ be continuous functions which are twice differentiable on the interval $(-1, 2)$. Let the values of f and g at the points $-1, 0$ and 2 be as given in the following table:

	$x = -1$	$x = 0$	$x = 2$
$f(x)$	3	6	0
$g(x)$	0	1	-1

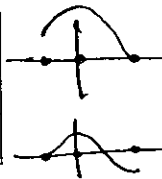

In each of the intervals $(-1, 0)$ and $(0, 2)$ the function $(f - 3g)''$ never vanishes. Then the correct statement(s) is(are) *not a constant*.

(A) $f'(x) - 3g'(x) = 0$ has exactly three solutions in $(-1, 0) \cup (0, 2)$

✓ (B) $f'(x) - 3g'(x) = 0$ has exactly one solution in $(-1, 0)$

✓ (C) $f'(x) - 3g'(x) = 0$ has exactly one solution in $(0, 2)$

(D) $f'(x) - 3g'(x) = 0$ has exactly two solutions in $(-1, 0)$ and exactly two solutions in $(0, 2)$

Space for rough work

$h(x) = f(x) - 3g(x)$ \int

Q.53 Let $f(x) = 7 \tan^8 x + 7 \tan^6 x - 3 \tan^4 x - 3 \tan^2 x$ for all $x \in \left(-\frac{\pi}{2}, \frac{\pi}{2}\right)$. Then the correct expression(s) is(are)

(A) $\int_0^{\pi/4} x f(x) dx = \frac{1}{12}$

(B) $\int_0^{\pi/4} f(x) dx = 0$

(C) $\int_0^{\pi/4} x f(x) dx = \frac{1}{6}$

(D) $\int_0^{\pi/4} f(x) dx = 1$

Q.54 Let $f'(x) = \frac{192x^3}{2 + \sin^4 \pi x}$ for all $x \in \mathbb{R}$ with $f\left(\frac{1}{2}\right) = 0$. If $m \leq \int_{1/2}^1 f(x) dx \leq M$, then the possible values of m and M are

(A) $m = 13, M = 24$

(B) $m = \frac{1}{4}, M = \frac{1}{2}$

(C) $m = -11, M = 0$

(D) $m = 1, M = 12$

Space for rough work

$\sec^2 n \cdot [7 \tan^6(n) - 3 \tan^2(n)]$

$f(x) = \sec^2 n \tan^2 n [7 \tan^4 n - 3] dn$

$\tan^4 n = t$

$4 \tan^3 n \sec^2 n dn = dt$

$\int \frac{(7t-3) dt}{4t^{1/4}}$

$\frac{7}{4} t^{3/4} - \frac{3}{4} t^{-1/4}$

$\frac{7}{4} \times \frac{4}{7} t^{7/4} - t^{3/4} \Big|_0$

$\int_0^{\pi/4} \left(\frac{\pi}{4} - n\right) f(n)$

$+ \int_0^{\pi/4} n f(n)$

Q.55 Let S be the set of all non-zero real numbers α such that the quadratic equation $\alpha x^2 - x + \alpha = 0$ has two distinct real roots x_1 and x_2 satisfying the inequality $|x_1 - x_2| < 1$. Which of the following intervals is(are) a subset(s) of S ?

- (A) $(-\frac{1}{2}, -\frac{1}{\sqrt{5}})$
 (B) $(-\frac{1}{\sqrt{5}}, 0)$
 (C) $(0, \frac{1}{\sqrt{5}})$
 (D) $(\frac{1}{\sqrt{5}}, \frac{1}{2})$

Q.56 If $\alpha = 3\sin^{-1}(\frac{6}{11})$ and $\beta = 3\cos^{-1}(\frac{4}{9})$, where the inverse trigonometric functions take only the principal values, then the correct option(s) is(are)

- (A) $\cos \beta > 0$
 (B) $\sin \beta < 0$
 (C) $\cos(\alpha + \beta) > 0$
 (D) $\cos \alpha < 0$

Space for rough work

$$x^2 - \frac{1}{\alpha}x + 1 = 0.$$

$$\left| \sqrt{(\alpha + \beta)^2 - 4\alpha\beta} \right| < 1.$$

$$= \sqrt{\left(\frac{1}{\alpha}\right)^2 - 4} < 1.$$

$$0 < \left(\frac{1}{\alpha}\right)^2 - 4 < 1$$

$$4 < \frac{1}{\alpha^2} < 5.$$

$$\frac{1}{4} > \alpha^2 > \frac{1}{5}$$

$$\sin 3\alpha = 3\sin \alpha - 4\sin^3 \alpha$$

$$= 3 \cdot \frac{18}{11} - 4 \cdot \left(\frac{6}{11}\right)^3$$

$$\cos 3\alpha = 4\cos^3 \alpha - 3\cos \alpha$$

$$= 4 \cdot \frac{4}{9} - 3 \cdot \frac{4}{9}$$

$$\left(-\frac{1}{\sqrt{5}}, -\frac{1}{\sqrt{5}}\right) \cup \left(\frac{1}{\sqrt{5}}, \frac{1}{\sqrt{5}}\right)$$

$$\frac{6}{11} = \sin\left(\frac{\alpha}{3}\right)$$

$$\frac{4}{9} = \cos\left(\frac{\beta}{3}\right)$$

[Handwritten scribble]

SECTION 3 (Maximum Marks : 16)

- This section contains **TWO** paragraphs
- Based on each paragraph, there will be **TWO** questions
- Each question has **FOUR** options (A), (B), (C) and (D). **ONE OR MORE THAN ONE** of these four option(s) is(are) correct
- For each question, darken the bubble(s) corresponding to all the correct option(s) in the ORS
- Marking scheme :
 - +4 If only the bubble(s) corresponding to all the correct option(s) is(are) darkened
 - 0 If none of the bubbles is darkened
 - 2 In all other cases

PARAGRAPH 1

Let $F: \mathbb{R} \rightarrow \mathbb{R}$ be a thrice differentiable function. Suppose that $F(1)=0$, $F(3)=-4$ and $F'(x) < 0$ for all $x \in (1/2, 3)$. Let $f(x) = xF(x)$ for all $x \in \mathbb{R}$.

dec.

Q.57 The correct statement(s) is(are)

- (A) $f(1) < 0$
- (B) $f(2) < 0$
- (C) $f'(x) \neq 0$ for any $x \in (1, 3)$
- (D) $f'(x) = 0$ for some $x \in (1, 3)$

$F(x) = -ve \quad x \in (1, 3)$
 $F'(x) = -ve \quad x \in (1, 3)$

Q.58 If $\int_1^3 x^2 F'(x) dx = -12$ and $\int_1^3 x^3 F''(x) dx = 40$, then the correct expression(s) is(are)

- (A) $9f'(3) + f'(1) - 32 = 0$
- (B) $\int_1^3 f(x) dx = 12$
- (C) $9f'(3) - f'(1) + 32 = 0$
- (D) $\int_1^3 f(x) dx = -12$

$F(1) - F'(1)$

$0 - F'(1) \quad +ve$

Space for rough work

$+ve -$

$f'(x) = F(x) - xF'(x)$
 $= 0 - 1F'(1)$
 $0 - 1F'(1)$

F
 $-4 - (3F'(3))$

-4

$3x - 4$

$n_1 = \text{red}$
 $n_2 = \text{black}$
I

$n_3 = \text{red}$
 $n_4 = \text{black}$
II

PARAGRAPH 2

Let n_1 and n_2 be the number of red and black balls, respectively, in box I. Let n_3 and n_4 be the number of red and black balls, respectively, in box II.

- Q.59 One of the two boxes, box I and box II, was selected at random and a ball was drawn randomly out of this box. The ball was found to be red. If the probability that this red ball was drawn from box II is $\frac{1}{3}$, then the correct option(s) with the possible values of n_1, n_2, n_3 and n_4 is(are)
- (A) $n_1 = 3, n_2 = 3, n_3 = 5, n_4 = 15$
 - (B) $n_1 = 3, n_2 = 6, n_3 = 10, n_4 = 50$
 - (C) $n_1 = 8, n_2 = 6, n_3 = 5, n_4 = 20$
 - (D) $n_1 = 6, n_2 = 12, n_3 = 5, n_4 = 20$

- Q.60 A ball is drawn at random from box I and transferred to box II. If the probability of drawing a red ball from box I, after this transfer, is $\frac{1}{3}$, then the correct option(s) with the possible values of n_1 and n_2 is(are)
- (A) $n_1 = 4$ and $n_2 = 6$
 - (B) $n_1 = 2$ and $n_2 = 3$
 - (C) $n_1 = 10$ and $n_2 = 20$
 - (D) $n_1 = 3$ and $n_2 = 6$

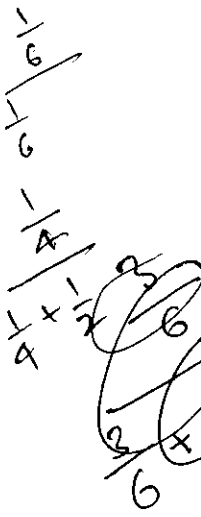

$\frac{n_1}{n_1 + n_2} = \frac{1}{3}$
 $3n_1 = n_1 + n_2$
 $2n_1 = n_2$

$\frac{\frac{1}{2} \times \frac{n_3}{n_3 + n_4}}{\frac{1}{2} \times \frac{n_3}{n_3 + n_4} + \frac{1}{2} \times \frac{n_1}{n_1 + n_2}} = \frac{1}{3}$

END OF THE QUESTION PAPER

Handwritten calculations for Q.60:

- $\frac{1}{6} + \frac{1}{3} = \frac{1}{5}$
- $\frac{1}{5} + \frac{4}{7} = \frac{1}{7}$
- $\frac{1}{6} + \frac{1}{3} = \frac{1}{5}$
- $\frac{1}{5} + \frac{1}{3} = \frac{8}{15}$
- $\frac{1}{4} + \frac{1}{2} = \frac{3}{4}$
- $\frac{1}{4} + \frac{1}{2} = \frac{3}{4}$
- $\frac{1}{6} + \frac{1}{2} = \frac{2}{3}$
- $\frac{1}{6} + \frac{1}{2} = \frac{2}{3}$
- $\frac{1}{5} + \frac{1}{3} = \frac{8}{15}$
- $\frac{1}{5} + \frac{1}{3} = \frac{8}{15}$
- $\frac{1}{4} + \frac{1}{2} = \frac{3}{4}$
- $\frac{1}{4} + \frac{1}{2} = \frac{3}{4}$
- $\frac{1}{6} + \frac{1}{2} = \frac{2}{3}$
- $\frac{1}{6} + \frac{1}{2} = \frac{2}{3}$