

P1-12-2-5

403435

CODE

5

PAPER 1

Time: 3 Hours

Maximum Marks: 210

Please read the instructions carefully. You are allotted 5 minutes specifically for this purpose.

INSTRUCTIONS :

A. General

1. This booklet is your Question Paper. Do not break the seals of this booklet before being instructed to do so by the invigilators.
2. The question paper CODE is printed on the right hand top corner of this page and on the back page (Page No. 28) of this booklet.
3. Blank spaces and blank pages are provided in this booklet for your rough work. No additional sheets will be provided for rough work.
4. Blank papers, clipboards, log tables, slide rules, calculators, cameras, cellular phones, pagers, and electronic gadgets are NOT allowed inside the examination hall.
5. Answers to the questions and personal details are to be filled on a two-part carbon-less paper, which is provided separately. You should not separate these parts. The invigilator will separate them at the end of examination. The upper sheet is a machine-gradable Objective Response Sheet (ORS) which will be taken back by the invigilator. You will be allowed to take away the bottom sheet at the end of the examination.
6. Using a black ball point pen, darken the bubbles on the upper original sheet. Apply sufficient pressure so that the impression is created on the bottom sheet.
7. DO NOT TAMPER WITH/MUTILATE THE ORS OR THE BOOKLET.
8. On breaking the seals of the booklet check that it contains 28 pages and all the 60 questions and corresponding answer choices are legible. Read carefully the instructions printed at the beginning of each section.

B. Filling the Right Part of the ORS

9. The ORS has CODES printed on its left and right parts.
10. Check that the same CODE is printed on the ORS and on this booklet. IF IT IS NOT THEN ASK FOR A CHANGE OF THE BOOKLET. Sign at the place provided on the ORS affirming that you have verified that all the codes are same.
11. Write your Name, Registration Number and the name of examination centre and sign with pen in the boxes provided on the right part of the ORS. Do not write any of this information anywhere else. Darken the appropriate bubble UNDER each digit of your Registration Number in such a way that the impression is created on the bottom sheet. Also darken the paper CODE given on the right side of ORS (R4).

C. Question Paper Format

- The question paper consists of 3 parts (Physics, Chemistry and Mathematics). Each part consists of three sections.
12. Section I contains 10 multiple choice questions. Each question has four choices (A), (B), (C) and (D) out of which ONLY ONE is correct.
 13. Section II contains 5 multiple choice questions. Each question has four choices (A), (B), (C) and (D) out of which ONE OR MORE are correct.
 14. Section III contains 5 questions. The answer to each question is a single digit integer, ranging from 0 to 9 (both inclusive).

D. Marking Scheme

15. For each question in Section I, you will be awarded 3 marks if you darken the bubble corresponding to the correct answer ONLY and zero marks if no bubbles are darkened. In all other cases, minus one (-1) mark will be awarded in this section.
16. For each question in Section II, you will be awarded 4 marks if you darken ALL the bubble(s) corresponding to the correct answer(s) ONLY. In all other cases zero (0) marks will be awarded. No negative marks will be awarded for incorrect answers in this section.
17. For each question in Section III, you will be awarded 4 marks if you darken the bubble corresponding to the correct answer ONLY. In all other cases zero (0) marks will be awarded. No negative marks will be awarded for incorrect answers in this section.

Write your Name, Registration Number and sign in the space provided on the back page of this booklet.

SEAL

DO NOT BREAK THE SEALS WITHOUT BEING INSTRUCTED TO DO SO BY THE INVIGILATOR



PART I : PHYSICS

SECTION I : Single Correct Answer Type

This section contains 10 multiple choice questions. Each question has four choices (A), (B), (C) and (D) out of which **ONLY ONE** is correct.

1. A small mass m is attached to a massless string whose other end is fixed at P as shown in the figure. The mass is undergoing circular motion in the x - y plane with centre at O and constant angular speed ω . If the angular momentum of the system, calculated about O and P are denoted by \vec{L}_O and \vec{L}_P respectively, then

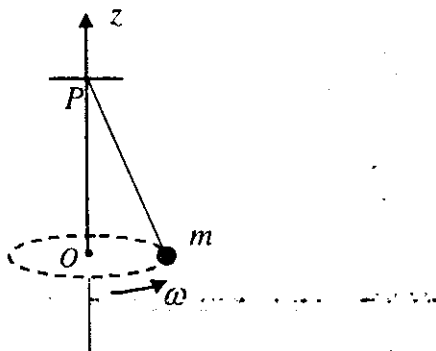

- (A) \vec{L}_O and \vec{L}_P **do not** vary with time.
(B) \vec{L}_O varies with time while \vec{L}_P remains constant.
(C) \vec{L}_O remains constant while \vec{L}_P varies with time.
(D) \vec{L}_O and \vec{L}_P both vary with time.

Space for Rough Work



2. A bi-convex lens is formed with two thin plano-convex lenses as shown in the figure. Refractive index n of the first lens is 1.5 and that of the second lens is 1.2. Both the curved surfaces are of the same radius of curvature $R = 14$ cm. For this bi-convex lens, for an object distance of 40 cm, the image distance will be

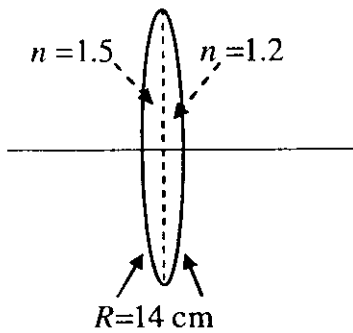

(A) -280.0 cm.

(B) 40.0 cm.

(C) 21.5 cm.

(D) 13.3 cm.

Space for Rough Work



3. A thin uniform rod, pivoted at O , is rotating in the horizontal plane with constant angular speed ω , as shown in the figure. At time $t = 0$, a small insect starts from O and moves with constant speed v with respect to the rod towards the other end. It reaches the end of the rod at $t = T$ and stops. The angular speed of the system remains ω throughout. The magnitude of the torque ($|\vec{\tau}|$) on the system about O , as a function of time is best represented by which plot ?

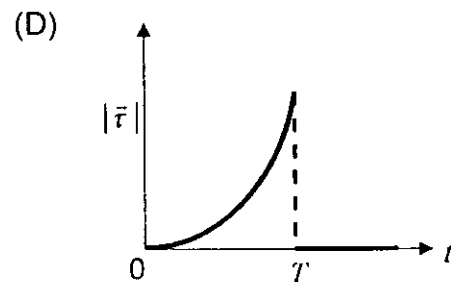
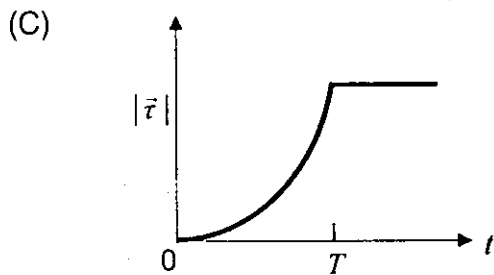
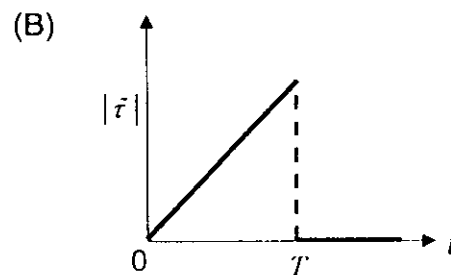
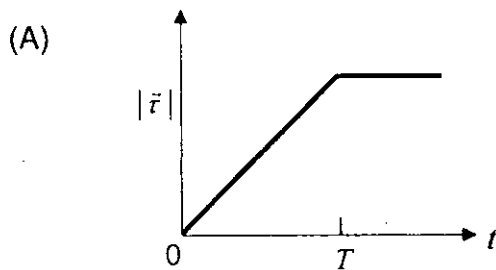
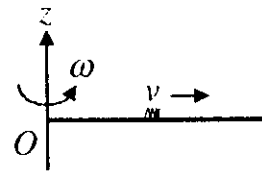

Space for Rough Work

4. A mixture of 2 moles of helium gas (atomic mass = 4 amu) and 1 mole of argon gas (atomic mass = 40 amu) is kept at 300 K in a container. The ratio of the rms speeds

$$\left(\frac{v_{rms}(\text{helium})}{v_{rms}(\text{argon})} \right) \text{ is}$$

- (A) 0.32 (B) 0.45 (C) 2.24 (D) 3.16

5. Two large vertical and parallel metal plates having a separation of 1 cm are connected to a DC voltage source of potential difference X . A proton is released at rest midway between the two plates. It is found to move at 45° to the vertical JUST after release. Then X is nearly

- (A) 1×10^{-5} V (B) 1×10^{-7} V (C) 1×10^{-9} V (D) 1×10^{-10} V

6. Three very large plates of same area are kept parallel and close to each other. They are considered as ideal black surfaces and have very high thermal conductivity. The first and third plates are maintained at temperatures $2T$ and $3T$ respectively. The temperature of the middle (i.e. second) plate under steady state condition is

- (A) $\left(\frac{65}{2}\right)^{\frac{1}{4}} T$ (B) $\left(\frac{97}{4}\right)^{\frac{1}{4}} T$ (C) $\left(\frac{97}{2}\right)^{\frac{1}{4}} T$ (D) $(97)^{\frac{1}{4}} T$

7. A small block is connected to one end of a massless spring of un-stretched length 4.9 m. The other end of the spring (see the figure) is fixed. The system lies on a horizontal frictionless surface. The block is stretched by 0.2 m and released from rest at $t = 0$. It then executes simple harmonic motion with angular frequency $\omega = \frac{\pi}{3}$ rad/s. Simultaneously at $t = 0$, a small pebble is projected with speed v from point P at an angle of 45° as shown in the figure. Point P is at a horizontal distance of 10 m from O . If the pebble hits the block at $t = 1$ s, the value of v is (take $g = 10 \text{ m/s}^2$)

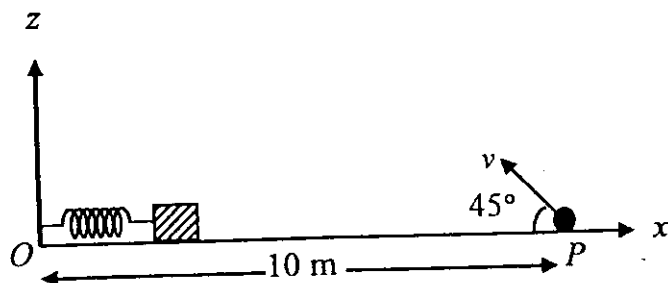

- (A) $\sqrt{50}$ m/s (B) $\sqrt{51}$ m/s (C) $\sqrt{52}$ m/s (D) $\sqrt{53}$ m/s

Space for Rough Work

8. Young's double slit experiment is carried out by using green, red and blue light, one color at a time. The fringe widths recorded are β_G , β_R and β_B , respectively. Then,

- (A) $\beta_G > \beta_B > \beta_R$ (B) $\beta_B > \beta_G > \beta_R$ (C) $\beta_R > \beta_B > \beta_G$ (D) $\beta_R > \beta_G > \beta_B$

9. Consider a thin spherical shell of radius R with its centre at the origin, carrying uniform positive surface charge density. The variation of the magnitude of the electric field $|\vec{E}(r)|$ and the electric potential $V(r)$ with the distance r from the centre, is best represented by which graph ?

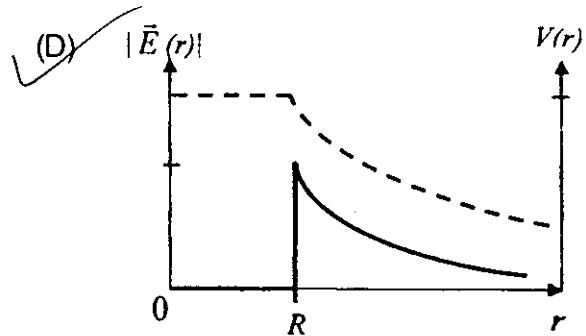
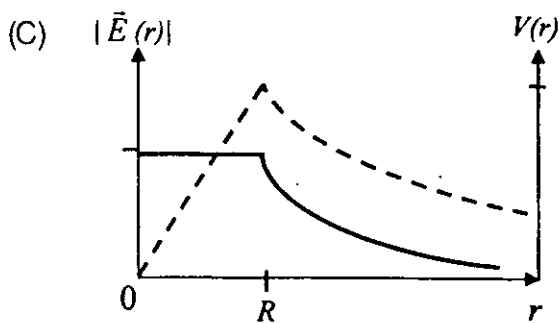
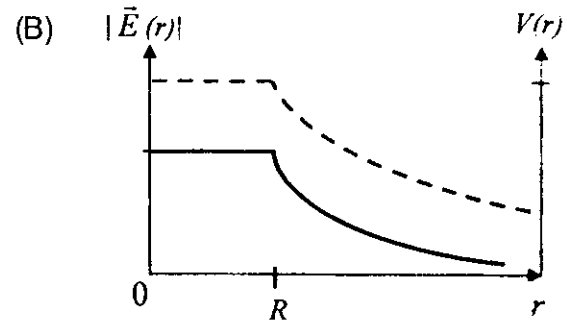
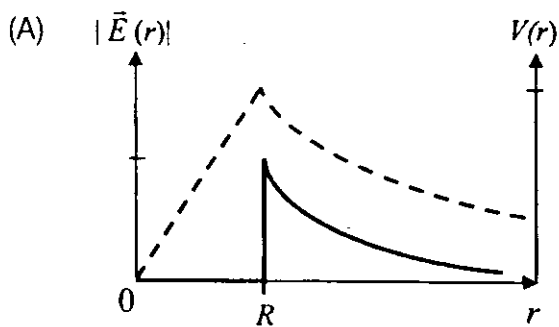

Space for Rough Work



10. In the determination of Young's modulus $\left(Y = \frac{4MLg}{\pi ld^2} \right)$ by using Searle's method, a wire of length $L = 2$ m and diameter $d = 0.5$ mm is used. For a load $M = 2.5$ kg, an extension $l = 0.25$ mm in the length of the wire is observed. Quantities d and l are measured using a screw gauge and a micrometer, respectively. They have the same pitch of 0.5 mm. The number of divisions on their circular scale is 100. The contributions to the maximum probable error of the Y measurement
- (A) due to the errors in the measurements of d and l are the same.
 - (B) due to the error in the measurement of d is twice that due to the error in the measurement of l .
 - (C) due to the error in the measurement of l is twice that due to the error in the measurement of d .
 - (D) due to the error in the measurement of d is four times that due to the error in the measurement of l .

Space for Rough Work

SECTION II : Multiple Correct Answer(s) Type

This section contains 5 multiple choice questions. Each question has four choices (A), (B), (C) and (D) out of which ONE or MORE are correct.

11. Consider the motion of a positive point charge in a region where there are simultaneous uniform electric and magnetic fields $\vec{E} = E_0 \hat{j}$ and $\vec{B} = B_0 \hat{j}$. At time $t = 0$, this charge has velocity \vec{v} in the x - y plane, making an angle θ with the x -axis. Which of the following option(s) is(are) correct for time $t > 0$?
- (A) If $\theta = 0^\circ$, the charge moves in a circular path in the x - z plane.
- (B) If $\theta = 0^\circ$, the charge undergoes helical motion with constant pitch along the y -axis.
- (C) If $\theta = 10^\circ$, the charge undergoes helical motion with its pitch increasing with time, along the y -axis.
- (D) If $\theta = 90^\circ$, the charge undergoes linear but accelerated motion along the y -axis.
12. A cubical region of side a has its centre at the origin. It encloses three fixed point charges, $-q$ at $(0, -a/4, 0)$, $+3q$ at $(0, 0, 0)$ and $-q$ at $(0, +a/4, 0)$. Choose the correct option(s).

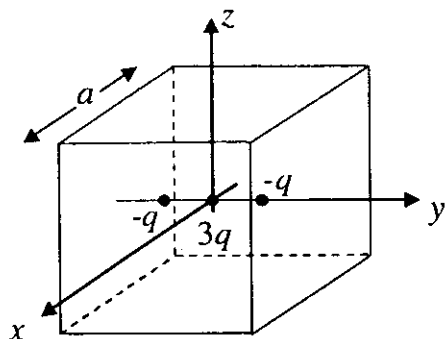

- (A) The net electric flux crossing the plane $x = +a/2$ is equal to the net electric flux crossing the plane $x = -a/2$.
- (B) The net electric flux crossing the plane $y = +a/2$ is more than the net electric flux crossing the plane $y = -a/2$.
- (C) The net electric flux crossing the entire region is $\frac{q}{\epsilon_0}$.
- (D) The net electric flux crossing the plane $z = +a/2$ is equal to the net electric flux crossing the plane $x = +a/2$.

Space for Rough Work



13. A person blows into open-end of a long pipe. As a result, a high-pressure pulse of air travels down the pipe. When this pulse reaches the other end of the pipe,
- (A) a high-pressure pulse starts traveling up the pipe, if the other end of the pipe is open.
 - (B) a low-pressure pulse starts traveling up the pipe, if the other end of the pipe is open.
 - (C) a low-pressure pulse starts traveling up the pipe, if the other end of the pipe is closed.
 - (D) a high-pressure pulse starts traveling up the pipe, if the other end of the pipe is closed.
14. A small block of mass of 0.1 kg lies on a fixed inclined plane PQ which makes an angle θ with the horizontal. A horizontal force of 1 N acts on the block through its center of mass as shown in the figure. The block remains stationary if (take $g = 10 \text{ m/s}^2$)

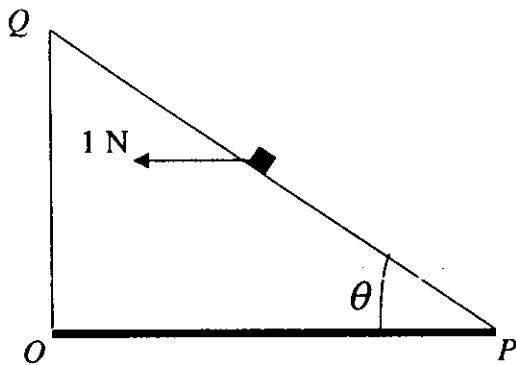

- (A) $\theta = 45^\circ$.
- (B) $\theta > 45^\circ$ and a frictional force acts on the block towards P .
- (C) $\theta > 45^\circ$ and a frictional force acts on the block towards Q .
- (D) $\theta < 45^\circ$ and a frictional force acts on the block towards Q .

Space for Rough Work



15. For the resistance network shown in the figure, choose the correct option(s).

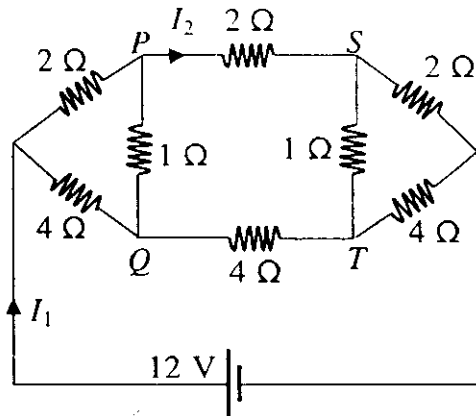

(A) The current through PQ is zero.

(B) $I_1 = 3\text{ A}$.

(C) The potential at S is less than that at Q.

(D) $I_2 = 2\text{ A}$.

Space for Rough Work

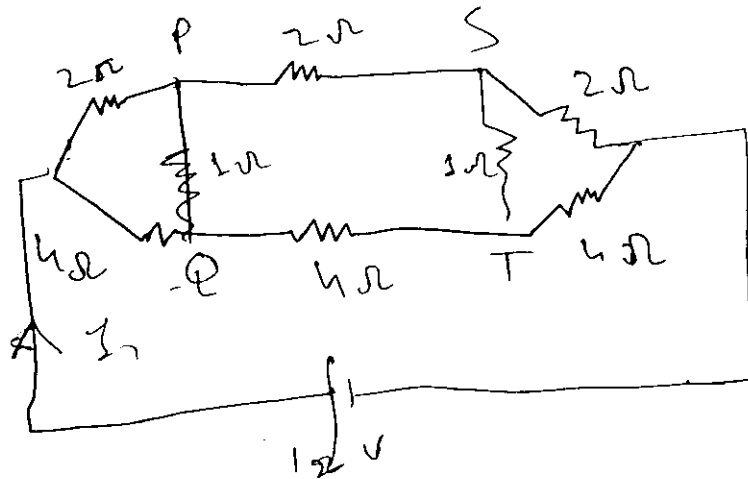

$$1 + \frac{1}{2} + \frac{1}{4} = \frac{7}{4}$$

$$2\Omega + 4\Omega = 6\Omega$$

$$\frac{1}{5} + \frac{1}{1} + 2 + 4 = 8$$



SECTION III : Integer Answer Type

This section contains 5 questions. The answer to each question is a **single digit integer**, ranging from 0 to 9 (both inclusive).

16. A circular wire loop of radius R is placed in the x - y plane centered at the origin O . A square loop of side a ($a \ll R$) having two turns is placed with its center at $z = \sqrt{3}R$ along the axis of the circular wire loop, as shown in figure. The plane of the square loop makes an angle of 45° with respect to the z -axis. If the mutual inductance between the loops is given by $\frac{\mu_0 a^2}{2^{p/2} R}$, then the value of p is

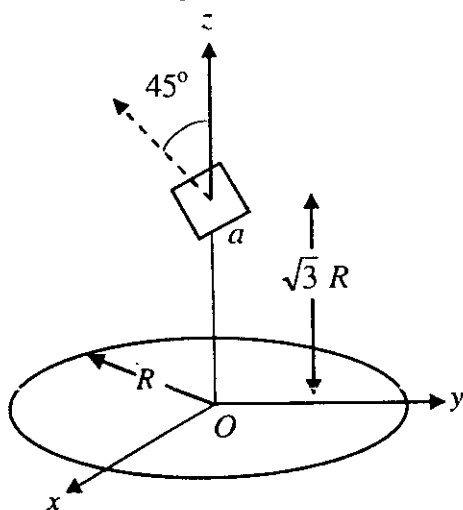

6

17. An infinitely long solid cylinder of radius R has a uniform volume charge density ρ . It has a spherical cavity of radius $R/2$ with its centre on the axis of the cylinder, as shown in the figure. The magnitude of the electric field at the point P , which is at a distance $2R$ from the axis of the cylinder, is given by the expression $\frac{23\rho R}{16k\epsilon_0}$. The value of k is

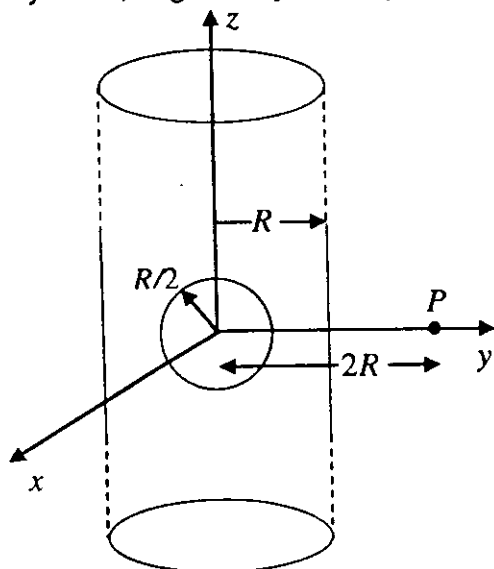

2



18. A proton is fired from very far away towards a nucleus with charge $Q = 120 e$, where e is the electronic charge. It makes a closest approach of 10 fm to the nucleus. The de Broglie wavelength (in units of fm) of the proton at its start is: (take the proton mass, $m_p = (5/3) \times 10^{-27}$ kg:

$h/e = 4.2 \times 10^{-15}$ J.s/C; $\frac{1}{4\pi\epsilon_0} = 9 \times 10^9$ m/F; 1 fm = 10^{-15} m)

9

19. A lamina is made by removing a small disc of diameter $2R$ from a bigger disc of uniform mass density and radius $2R$, as shown in the figure. The moment of inertia of this lamina about axes passing through O and P is I_O and I_P , respectively. Both these axes are perpendicular

to the plane of the lamina. The ratio $\frac{I_P}{I_O}$ to the nearest integer is

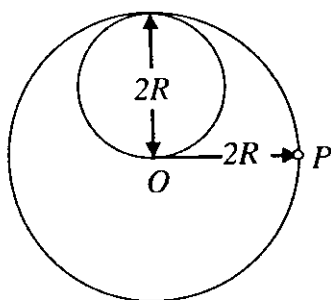

7

20. A cylindrical cavity of diameter a exists inside a cylinder of diameter $2a$ as shown in the figure. Both the cylinder and the cavity are infinitely long. A uniform current density J flows along the length.

If the magnitude of the magnetic field at the point P is given by $\frac{N}{12} \mu_0 aJ$, then the value of N is

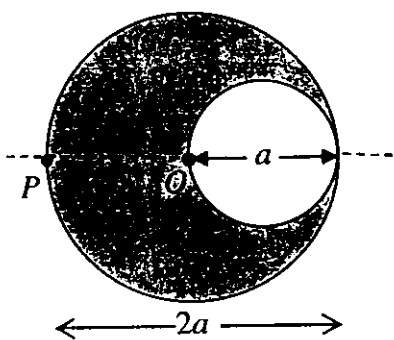

5

Space for Rough Work

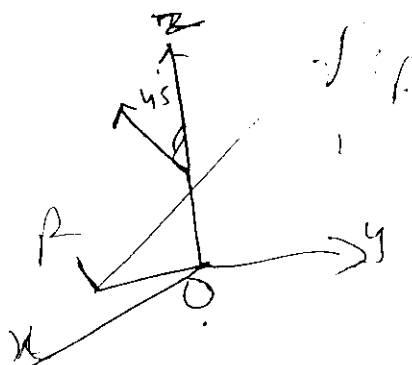

5

PART II : CHEMISTRY

SECTION I : Single Correct Answer Type

This section contains 10 multiple choice questions. Each question has four choices (A), (B), (C) and (D) out of which **ONLY ONE** is correct.

21. The carboxyl functional group ($-\text{COOH}$) is present in
(A) picric acid (B) barbituric acid (C) ascorbic acid (D) aspirin
22. As per IUPAC nomenclature, the name of the complex $[\text{Co}(\text{H}_2\text{O})_4(\text{NH}_3)_2]\text{Cl}_3$ is
(A) Tetraaquadiaminocobalt (III) chloride
(B) Tetraaquadiamminocobalt (III) chloride
 (C) Diaminetetraaquacobalt (III) chloride
(D) Diamminetetraaquacobalt (III) chloride
23. In allene (C_3H_4), the type(s) of hybridisation of the carbon atoms is (are)
(A) sp and sp^3 (B) sp and sp^2 (C) only sp^2 (D) sp^2 and sp^3
24. The kinetic energy of an electron in the second Bohr orbit of a hydrogen atom is [a_0 is Bohr radius]
(A) $\frac{h^2}{4\pi^2ma_0^2}$ (B) $\frac{h^2}{16\pi^2ma_0^2}$ (C) $\frac{h^2}{32\pi^2ma_0^2}$ (D) $\frac{h^2}{64\pi^2ma_0^2}$

Space for Rough Work

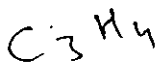



25. Which ordering of compounds is according to the decreasing order of the oxidation state of nitrogen?

- (A) HNO_3 , NO , NH_4Cl , N_2 (B) HNO_3 , NO , N_2 , NH_4Cl
(C) HNO_3 , NH_4Cl , NO , N_2 (D) NO , HNO_3 , NH_4Cl , N_2

26. For one mole of a van der Waals gas when $b = 0$ and $T = 300 \text{ K}$, the PV vs. $1/V$ plot is shown below. The value of the van der Waals constant a ($\text{atm}\cdot\text{liter}^2 \text{ mol}^{-2}$) is

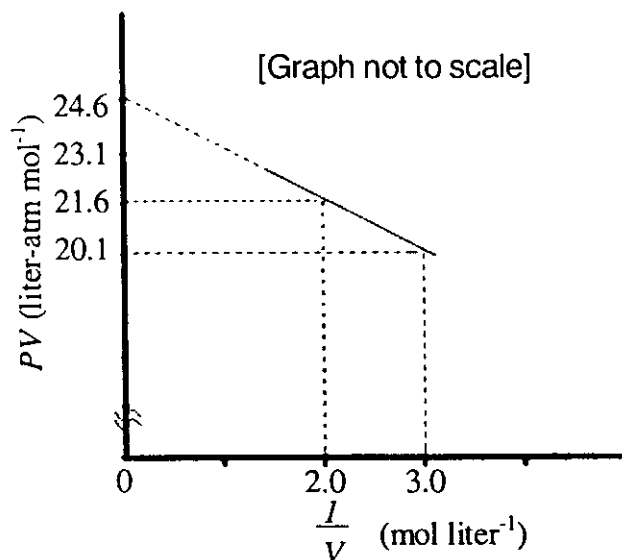

- (A) 1.0 (B) 4.5 (C) 1.5 (D) 3.0

27. The number of aldol reaction(s) that occurs in the given transformation is

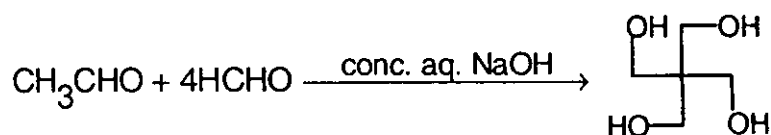

- (A) 1 (B) 2 (C) 3 (D) 4

Space for Rough Work

28. The colour of light absorbed by an aqueous solution of CuSO_4 is

- (A) orange-red (B) blue-green (C) yellow (D) violet

The number of optically active products obtained from the **complete** ozonolysis of the given compound is

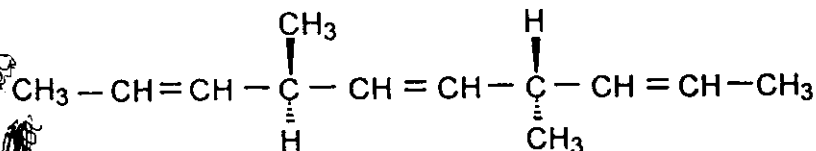

- (A) 0 (B) 1 (C) 2 (D) 4

30. A compound M_pX_q has cubic close packing (ccp) arrangement of X. Its unit cell structure is shown below. The empirical formula of the compound is

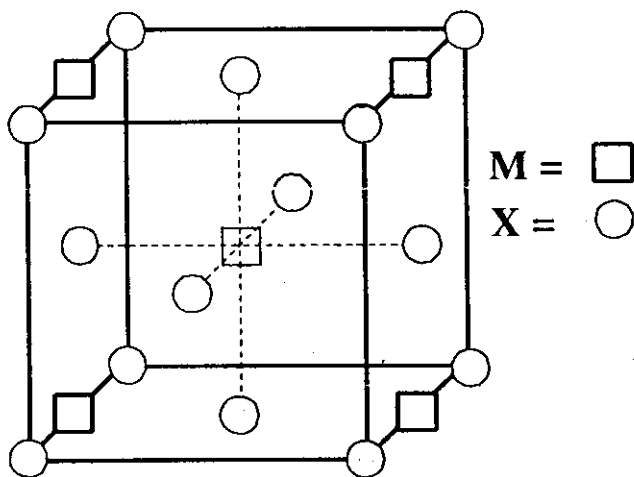

- (A) MX (B) MX_2 (C) M_2X (D) M_5X_{14}

Space for Rough Work

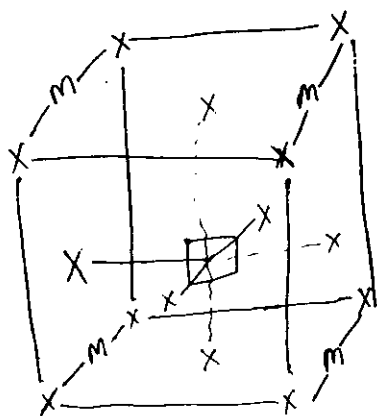

SECTION II : Multiple Correct Answer(s) Type

This section contains 5 multiple choice questions. Each question has four choices (A), (B), (C) and (D) out of which ONE or MORE are correct.

31. Which of the following hydrogen halides react(s) with $\text{AgNO}_3(\text{aq})$ to give a precipitate that dissolves in $\text{Na}_2\text{S}_2\text{O}_3(\text{aq})$?

- (A) HCl (B) HF (C) HBr (D) HI

32. Identify the binary mixture(s) that can be separated into individual compounds, by differential extraction, as shown in the given scheme.

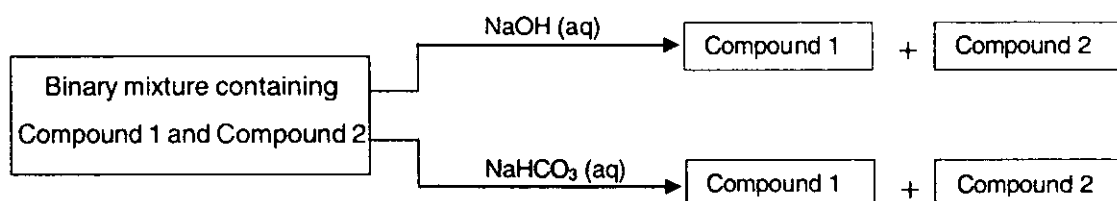

- (A) $\text{C}_6\text{H}_5\text{OH}$ and $\text{C}_6\text{H}_5\text{COOH}$ (B) $\text{C}_6\text{H}_5\text{COOH}$ and $\text{C}_6\text{H}_5\text{CH}_2\text{OH}$
 (C) $\text{C}_6\text{H}_5\text{CH}_2\text{OH}$ and $\text{C}_6\text{H}_5\text{OH}$ (D) $\text{C}_6\text{H}_5\text{CH}_2\text{OH}$ and $\text{C}_6\text{H}_5\text{CH}_2\text{COOH}$

Space for Rough Work

Handwritten notes and chemical reactions:

- $\text{HCl} + \text{AgNO}_3 \rightarrow \text{HNO}_3 + \text{AgCl}$
- $\text{HF} + \text{AgNO}_3 \rightarrow \text{HNO}_3 + \text{AgF}$
- $\text{HBr} + \text{AgNO}_3 \rightarrow \text{HNO}_3 + \text{AgBr}$
- $\text{HI} + \text{AgNO}_3 \rightarrow \text{HNO}_3 + \text{AgI}$
- $\text{C}_6\text{H}_5\text{OH} \xrightarrow{\text{NaOH(aq)}} \text{C}_6\text{H}_5\text{O}^- \text{Na}^+$
- $\text{C}_6\text{H}_5\text{COOH} \xrightarrow{\text{NaHCO}_3(\text{aq})} \text{C}_6\text{H}_5\text{COO}^- \text{Na}^+ + \text{H}_2\text{O} + \text{CO}_2$
- $\text{C}_6\text{H}_5\text{COOH} \xrightarrow{\text{NaOH(aq)}} \text{C}_6\text{H}_5\text{COO}^- \text{Na}^+ + \text{H}_2\text{O}$
- $\text{C}_6\text{H}_5\text{CH}_2\text{OH} \xrightarrow{\text{NaHCO}_3} \text{C}_6\text{H}_5\text{CH}_2\text{O}^- \text{Na}^+ + \text{H}_2\text{O} + \text{CO}_2$
- $\text{C}_6\text{H}_5\text{CH}_2\text{COOH} \xrightarrow{\text{NaOH}} \text{C}_6\text{H}_5\text{CH}_2\text{COO}^- \text{Na}^+ + \text{H}_2\text{O}$
- $\text{C}_6\text{H}_5\text{OH} \xrightarrow{\text{NaHCO}_3} \text{C}_6\text{H}_5\text{O}^- \text{Na}^+ + \text{H}_2\text{O} + \text{CO}_2$
- $2\text{AgCl} + \text{Na}_2\text{S}_2\text{O}_3 \rightarrow 2\text{Ag} + \text{Na}_2\text{SO}_4 + \text{S}$
- $\text{C}_6\text{H}_5\text{COOH} + \text{Na}_2\text{S}_2\text{O}_3 \rightarrow \text{C}_6\text{H}_5\text{COO}^- \text{Na}^+ + \text{H}_2\text{O} + \text{CO}_2$

33. For an ideal gas, consider only P - V work in going from an initial state X to the final state Z . The final state Z can be reached by either of the two paths shown in the figure. Which of the following choice(s) is (are) correct? [take ΔS as change in entropy and w as work done]

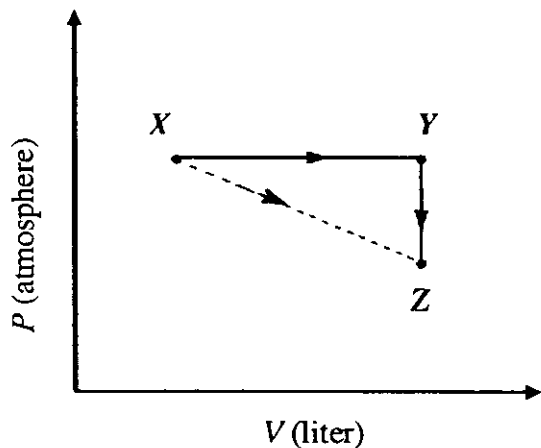

- (A) $\Delta S_{x \rightarrow z} = \Delta S_{x \rightarrow y} + \Delta S_{y \rightarrow z}$ (B) $w_{x \rightarrow z} = w_{x \rightarrow y} + w_{y \rightarrow z}$
 (C) $w_{x \rightarrow y \rightarrow z} = w_{x \rightarrow y}$ (D) $\Delta S_{x \rightarrow y \rightarrow z} = \Delta S_{x \rightarrow y}$

34. Which of the following molecules, in pure form, is (are) **unstable** at room temperature?

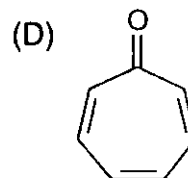
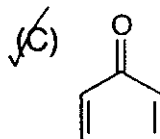
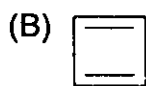
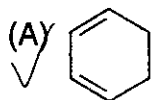

35. Choose the correct reason(s) for the stability of the **lyophobic** colloidal particles.

- (A) Preferential adsorption of ions on their surface from the solution
 (B) Preferential adsorption of solvent on their surface from the solution
 (C) Attraction between different particles having opposite charges on their surface
 (D) Potential difference between the fixed layer and the diffused layer of opposite charges around the colloidal particles

Space for Rough Work

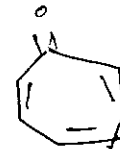



SECTION III : Integer Answer Type

This section contains 5 questions. The answer to each question is a **single digit integer**, ranging from 0 to 9 (both inclusive).

36. 29.2% (w/w) HCl stock solution has a density of 1.25 g mL^{-1} . The molecular weight of HCl is 36.5 g mol^{-1} . The volume (mL) of stock solution required to prepare a 200 mL solution of 0.4 M HCl is 6

37. The substituents R_1 and R_2 for nine peptides are listed in the table given below. How many of these peptides are positively charged at $\text{pH} = 7.0$?

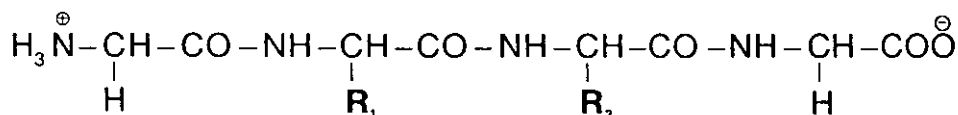

Peptide	R_1	R_2
I	H	H
II	H	CH_3
III	CH_2COOH	H
IV	CH_2CONH_2	$(\text{CH}_2)_4\text{NH}_2$
V	CH_2CONH_2	CH_2CONH_2
VI	$(\text{CH}_2)_4\text{NH}_2$	$(\text{CH}_2)_4\text{NH}_2$
VII	CH_2COOH	CH_2CONH_2
VIII	CH_2OH	$(\text{CH}_2)_4\text{NH}_2$
IX	$(\text{CH}_2)_4\text{NH}_2$	CH_3

Space for Rough Work

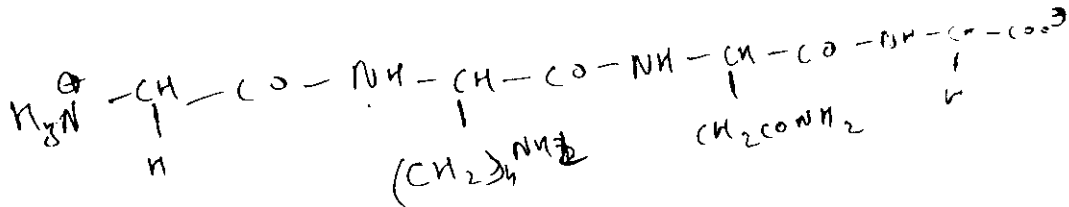

38. An organic compound undergoes first-order decomposition. The time taken for its decomposition to 1/8 and 1/10 of its initial concentration are $t_{1/8}$ and $t_{1/10}$ respectively.

What is the value of $\frac{[t_{1/8}]}{[t_{1/10}]} \times 10$? (take $\log_{10} 2 = 0.3$)

5

39. When the following aldohexose exists in its D-configuration, the total number of stereoisomers in its pyranose form is

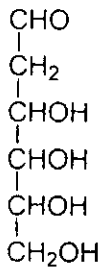

4

40. The periodic table consists of 18 groups. An isotope of copper, on bombardment with protons, undergoes a nuclear reaction yielding element X as shown below. To which group, element X belongs in the periodic table?

2

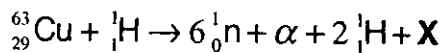

Space for Rough Work

G

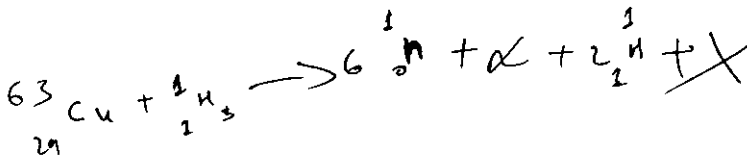

X \rightarrow 2

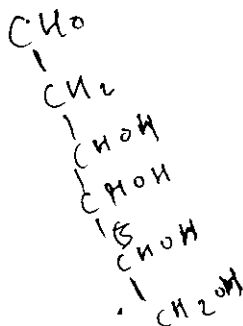

\rightarrow

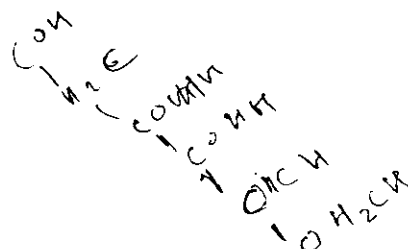



SECTION I : Single Correct Answer Type

This section contains 10 multiple choice questions. Each question has four choices (A), (B), (C) and (D) out of which **ONLY ONE** is correct.

41. Let $P = [a_{ij}]$ be a 3×3 matrix and let $Q = [b_{ij}]$, where $b_{ij} = 2^{i+j}a_{ij}$ for $1 \leq i, j \leq 3$. If the determinant of P is 2, then the determinant of the matrix Q is

- (A) 2^{10} (B) 2^{11} (C) 2^{12} (D) 2^{13}

42. The locus of the mid-point of the chord of contact of tangents drawn from points lying on the straight line $4x - 5y = 20$ to the circle $x^2 + y^2 = 9$ is

- (A) $20(x^2 + y^2) - 36x + 45y = 0$ (B) $20(x^2 + y^2) + 36x - 45y = 0$
 (C) $36(x^2 + y^2) - 20x + 45y = 0$ (D) $36(x^2 + y^2) + 20x - 45y = 0$

43. The total number of ways in which 5 balls of different colours can be distributed among 3 persons so that each person gets at least one ball is

- (A) 75 (B) 150 (C) 210 (D) 243

44. The integral $\int \frac{\sec^2 x}{(\sec x + \tan x)^{5/2}} dx$ equals (for some arbitrary constant K)

- (A) $-\frac{1}{(\sec x + \tan x)^{1/2}} \left\{ \frac{1}{11} - \frac{1}{7}(\sec x + \tan x)^2 \right\} + K$
 (B) $\frac{1}{(\sec x + \tan x)^{1/2}} \left\{ \frac{1}{11} - \frac{1}{7}(\sec x + \tan x)^2 \right\} + K$
 (C) $-\frac{1}{(\sec x + \tan x)^{1/2}} \left\{ \frac{1}{11} + \frac{1}{7}(\sec x + \tan x)^2 \right\} + K$
 (D) $\frac{1}{(\sec x + \tan x)^{1/2}} \left\{ \frac{1}{11} + \frac{1}{7}(\sec x + \tan x)^2 \right\} + K$

MATHEMATICS

Space for Rough Work

Let $\tan x = t \Rightarrow \sec^2 x dx = dt$ $= \int \frac{dt}{(\sqrt{1+t^2+t})^{5/2}}$

$36(x^2 + y^2) - 20x + 45y = 0$ $\frac{1 + \tan^2 x = \sec^2 x}{1 + t^2 = \sec^2 x}$

$36(x^2 + y^2) + 20x - 45y = 0$ $4x - 5y = 20$ $x^2 + y^2 = 9$

$20(x^2 + y^2) - 36x + 45y = 0$ $20(x^2 + y^2) - 36x + 45y = 0$; $20(x^2 + y^2) + 36x - 45y = 0$



45. The point P is the intersection of the straight line joining the points $Q(2, 3, 5)$ and $R(1, -1, 4)$ with the plane $5x - 4y - z = 1$. If S is the foot of the perpendicular drawn from the point $T(2, 1, 4)$ to QR , then the length of the line segment PS is

- (A) $\frac{1}{\sqrt{2}}$
- (B) $\sqrt{2}$
- (C) 2
- (D) $2\sqrt{2}$

46. Let $f(x) = \begin{cases} x^2 \left| \cos \frac{\pi}{x} \right|, & x \neq 0 \\ 0, & x = 0 \end{cases}, x \in \mathbb{R},$

then f is

- (A) differentiable both at $x=0$ and at $x=2$
- (B) differentiable at $x=0$ but not differentiable at $x=2$
- (C) not differentiable at $x=0$ but differentiable at $x=2$
- (D) differentiable neither at $x=0$ nor at $x=2$

Space for Rough Work

$f'(x) = x^2 \times \sin \frac{\pi}{x} \times \left| \cos \frac{\pi}{x} \right| + x^2 \sin \frac{\pi}{x} = 4$

$\frac{0}{0} = \frac{2}{4}$

$\frac{x^2 + x + 1}{x + 1} = \frac{3x^2 + 4x + 2}{x^2 + 1 + 2x} - 1 = 1$

$\frac{3x^2 + 4x + 2}{x^2 + 2x + 1} - 1 = 1$

$\frac{3x^2 + 4x + 2 - x^2 - 2x - 1}{x^2 + 2x + 1} = 1$

$\frac{2x^2 + 2x + 1}{x^2 + 2x + 1} = 1$

$2x^2 + 2x + 1 = x^2 + 2x + 1$

$x^2 = 0$

$x = 0$

$5x - 4y - z = 1$

$Q(2, 3, 5)$

$R(1, -1, 4)$

$T(2, 1, 4)$



$z = x + iy \Rightarrow E_2(0, 4)$

47. Let z be a complex number such that the imaginary part of z is nonzero and $a = z^2 + z + 1$ is real. Then a cannot take the value

- (A) -1
- (B) $\frac{1}{3}$
- (C) $\frac{1}{2}$
- (D) $\frac{3}{4}$

48. The ellipse $E_1 : \frac{x^2}{9} + \frac{y^2}{4} = 1$ is inscribed in a rectangle R whose sides are parallel to the coordinate axes. Another ellipse E_2 passing through the point $(0, 4)$ circumscribes the rectangle R . The eccentricity of the ellipse E_2 is

- (A) $\frac{\sqrt{2}}{2}$
- (B) $\frac{\sqrt{3}}{2}$
- (C) $\frac{1}{2}$
- (D) $\frac{3}{4}$

49. The function $f : [0, 3] \rightarrow [1, 29]$, defined by $f(x) = 2x^3 - 15x^2 + 36x + 1$, is

- (A) one-one and onto.
- (B) onto but not one-one.
- (C) one-one but not onto.
- (D) neither one-one nor onto.

50. If $\lim_{x \rightarrow \infty} \left(\frac{x^2 + x + 1}{x + 1} - ax - b \right) = 4$, then

- (A) $a = 1, b = 4$
- (B) $a = 1, b = -4$
- (C) $a = 2, b = -3$
- (D) $a = 2, b = 3$

Space for Rough Work

$z = x + iy \Rightarrow 1 = x + iy \Rightarrow iy = 1 - x$

$a = (x + iy)^2 + x + iy + 1$

$= x^2 - y^2 + 2xyi + x + iy + 1 = (x^2 - y^2 + x + 1) + i(2xy + y)$

$= x^2 - y^2 + x + 1 + (1 - x)(2x + y)$
 $= x^2 - y^2 + x + 1 + 2x + y - 2x^2 - xy$
 $= -x^2 - y^2 + 3x + y + 1$

~~$\Rightarrow (x+1)(2x+1) + (x^2+x+1) = a$~~

$= \frac{x^2+x+1}{x+1} - x - 4$

$= \frac{(x+1)(2x+1) + x^2+x+1 - 1}{(x+1)^2} = -1$

$= \frac{2x^2+3x+1+x^2+x+1-1}{x^2+2x+1}$

$= \frac{3x^2+4x+1}{x^2+2x+1} = \frac{3x+1}{x+1} \Rightarrow 2-1=1$

MATHEMATICS



SECTION II : Multiple Correct Answer(s) Type

This section contains 5 multiple choice questions. Each question has four choices (A), (B), (C) and (D) out of which **ONE or MORE** are correct.

51. Tangents are drawn to the hyperbola $\frac{x^2}{9} - \frac{y^2}{4} = 1$, parallel to the straight line $2x - y = 1$. The points of contact of the tangents on the hyperbola are

(A) $\left(\frac{9}{2\sqrt{2}}, \frac{1}{\sqrt{2}}\right)$

(B) $\left(-\frac{9}{2\sqrt{2}}, -\frac{1}{\sqrt{2}}\right)$

(C) $(3\sqrt{3}, -2\sqrt{2})$

(D) $(-3\sqrt{3}, 2\sqrt{2})$

52. Let $\theta, \varphi \in [0, 2\pi]$ be such that

$$2 \cos \theta (1 - \sin \varphi) = \sin^2 \theta \left(\tan \frac{\theta}{2} + \cot \frac{\theta}{2} \right) \cos \varphi - 1,$$

$$\tan(2\pi - \theta) > 0 \text{ and } -1 < \sin \theta < -\frac{\sqrt{3}}{2}.$$

Then φ **cannot** satisfy

(A) $0 < \varphi < \frac{\pi}{2}$

(B) $\frac{\pi}{2} < \varphi < \frac{4\pi}{3}$

(C) $\frac{4\pi}{3} < \varphi < \frac{3\pi}{2}$

(D) $\frac{3\pi}{2} < \varphi < 2\pi$

Space for Rough Work

$$2 \cos \theta (1 - \sin \varphi) = \sin^2 \theta \left(\tan \frac{\theta}{2} + \cot \frac{\theta}{2} \right) \cos \varphi - 1$$

$$\frac{\pi}{2} < \varphi < \frac{4\pi}{3} \Rightarrow \sin \frac{\pi}{2} \left(\cos \frac{4\pi}{3} \right) \cos \varphi = 3\pi$$

$$+ \cos^2 \dots$$

53. If $y(x)$ satisfies the differential equation $y' - y \tan x = 2x \sec x$ and $y(0) = 0$, then

(A) $y\left(\frac{\pi}{4}\right) = \frac{\pi^2}{8\sqrt{2}}$

~~(B)~~ $y'\left(\frac{\pi}{4}\right) = \frac{\pi^2}{18}$

(C) $y\left(\frac{\pi}{3}\right) = \frac{\pi^2}{9}$

(D) $y'\left(\frac{\pi}{3}\right) = \frac{4\pi}{3} + \frac{2\pi^2}{3\sqrt{3}}$

54. A ship is fitted with three engines E_1, E_2 and E_3 . The engines function independently of each other with respective probabilities $\frac{1}{2}, \frac{1}{4}$ and $\frac{1}{4}$. For the ship to be operational at least two of its engines must function. Let X denote the event that the ship is operational and let X_1, X_2 and X_3 denote respectively the events that the engines E_1, E_2 and E_3 are functioning. Which of the following is (are) true ?

~~(A)~~ $P[X_1^c | X] = \frac{3}{16}$

(B) $P[\text{Exactly two engines of the ship are functioning} | X] = \frac{7}{8}$

(C) $P[X | X_2] = \frac{5}{16}$

~~(D)~~ $P[X | X_1] = \frac{7}{16}$

55. Let S be the area of the region enclosed by $y = e^{-x^2}, y = 0, x = 0$, and $x = 1$. Then

(A) $S \geq \frac{1}{e}$

~~(B)~~ $S \geq 1 - \frac{1}{e}$

(C) $S \leq \frac{1}{4} \left(1 + \frac{1}{\sqrt{e}}\right)$

(D) $S \leq \frac{1}{\sqrt{2}} + \frac{1}{\sqrt{e}} \left(1 - \frac{1}{\sqrt{2}}\right)$

Space for Rough Work

$y' - y \tan x = 2x \sec x$

$\frac{dy}{dx} - y \tan x = 2x \sec x \Rightarrow \frac{dy}{dx} + Py = Q$

$P = -\tan x$

$Q = 2x \sec x$

~~$\frac{dy}{dx} = 2x \sec x + y \tan x$~~

~~$= 2x \frac{\pi}{4} \sec \frac{\pi}{4} + y \tan \frac{\pi}{4}$~~

~~$= \frac{\pi}{2} x + \sqrt{2} + y = y + \sqrt{2} \frac{\pi}{2}$~~

$-\int \tan x =$

$= -\log \left(\tan \frac{\pi}{4} \right)$



SECTION III : Integer Answer Type

This section contains 5 questions. The answer to each question is a single digit integer, ranging from 0 to 9 (both inclusive).

56. If \vec{a}, \vec{b} and \vec{c} are unit vectors satisfying $|\vec{a} - \vec{b}|^2 + |\vec{b} - \vec{c}|^2 + |\vec{c} - \vec{a}|^2 = 9$, then

$|2\vec{a} + 5\vec{b} + 5\vec{c}|$ is

A

57. Let $f: \mathbb{R} \rightarrow \mathbb{R}$ be defined as $f(x) = |x| + |x^2 - 1|$. The total number of points at which f attains either a local maximum or a local minimum is 3

58. Let S be the focus of the parabola $y^2 = 8x$ and let PQ be the common chord of the circle $x^2 + y^2 - 2x - 4y = 0$ and the given parabola. The area of the triangle PQS is 1

59. Let $p(x)$ be a real polynomial of least degree which has a local maximum at $x = 1$ and a local minimum at $x = 3$. If $p(1) = 6$ and $p(3) = 2$, then $p'(0)$ is 9

60. The value of $6 + \log_{\frac{3}{2}} \left(\frac{1}{3\sqrt{2}} \sqrt{4 - \frac{1}{3\sqrt{2}}} \sqrt{4 - \frac{1}{3\sqrt{2}}} \sqrt{4 - \frac{1}{3\sqrt{2}}} \dots \right)$ is 4

Space for Rough Work

~~6 + log~~ Let $\sqrt{4 - \frac{1}{3\sqrt{2}}} \sqrt{4 - \frac{1}{3\sqrt{2}}} \sqrt{4 - \frac{1}{3\sqrt{2}}} \dots = \frac{1}{3\sqrt{2}}$

$6 + \log_{\frac{3}{2}} \left(\frac{1}{3\sqrt{2}} y \right)$

$6 + \log_{\frac{3}{2}} \left(\frac{y\sqrt{2}}{6} \right) = 4$